

TO BMS 1F-16CM-34-1-1

AVIONICS AND NONNUCLEAR WEAPONS DELIVERY FLIGHT MANUAL



22 December 2020

FOREWORD

PURPOSE AND SCOPE

This manual contains data describing relevant aircraft avionics, weapons systems, support equipment and munitions designated for carriage on the aircraft and data necessary to execute air-to-air and air-to-ground missions employing nonnuclear munitions.

The following manuals supplement this manual to establish the complete Falcon BMS 4.35 series:

- TO-BMS1F-16CM-1 (aircraft, avionics, normal procedures and abnormal procedures).
- BMS-Training (documentation to accompany Falcon BMS training missions).
- BMS-Manual (Falcon 4 BMS 4.35 front end, anything specific to the simulation).
- Checklists and Cockpit Diagrams (avionics, emergency, non-F-16 pit layouts).
- BMS-Comms & Navigation Manual (with supporting KTO AIP, Charts, etc.).
- BMS-Technical Manual (Key Files & Editor, Keystrokes, Callbacks, etc.).
- BMS-Naval-Ops (Naval Operations from aircraft carriers in BMS).

These are all located in the `\Docs` folder of your Falcon BMS install, with other supporting documents.

COPYRIGHT STATEMENTS

Falcon BMS is a community mod developed and published by Benchmark Sims for use with licensed copies of Falcon 4.0. Unauthorized rental, sales, arcade use, charging for use, or any commercial use of this mod or part thereof is prohibited.

This mod is for non-commercial use only.

This mod was created by Benchmark Sims with the permission of Billion Soft (Hong Kong) Limited.

This mod and all included content are in no way affiliated with Billion Soft (Hong Kong) Limited or Retroism.

© 2003-2020 Benchmark Sims. All rights reserved.

Falcon is a registered trademark of Billion Soft (Hong Kong) Limited. Falcon Collection and Falcon 4.0 are published by Retroism.

Retroism, the Retroism logo and the Billion Soft logo are trademarks or registered trademarks.

© 2020 Billion Soft (Hong Kong) Limited. All rights reserved.

The manufacturers and intellectual property right owners of the vehicles, weapons, sensors and other systems represented in Falcon BMS in no way endorse, sponsor or are otherwise involved in the development of Falcon BMS.

The TO BMS 1F-16CM-34-1-1 manual is published by the BMS DOC team.

Unauthorized rental, sales, charging for use, or any commercial use of this manual or part thereof is prohibited.

This manual is for non-commercial use only.

No reproduction of this manual or part of this manual is allowed without the written permission of the BMS DOC team.

© 2003-2020 Benchmark Sims. All rights reserved.

0 TABLE OF CONTENTS

0	TABLE OF CONTENTS.....	3
0.1	LIST OF FIGURES.....	7
0.2	LIST OF TABLES.....	12
1	AVIONICS SYSTEMS AND CONTROLS.....	13
1.1	COCKPIT CONTROLS AND DISPLAYS	14
1.1.1	Philosophy of Cockpit Controls and Displays.....	15
1.1.2	F-16 Mode and Sensor Concepts.....	21
1.2	INERTIAL NAVIGATION SYSTEM (INS).....	23
1.2.1	Steerpoints.....	23
1.2.2	DED pages.....	23
1.2.3	Sighting Options.....	27
1.3	TACAN.....	31
1.3.1	Air-to-Ground Modelling	32
1.3.2	Air-to-Air Modelling.....	32
1.4	AN/APG-68(V)5 FIRE CONTROL RADAR	34
1.4.1	Background.....	34
1.4.2	FCR Controls.....	36
1.4.3	Radar Modes.....	40
1.4.4	Radar Air-to-Air Modes.....	45
1.4.5	Radar Air-to-Ground Modes.....	77
1.4.6	FCR Faults.....	85
1.5	IMPROVED DATA MODEM (IDM)	86
1.5.1	Background.....	86
1.5.2	Data Link Operation Overview.....	86
1.5.3	Data Link Symbology.....	87
1.5.4	Data Link Initialization via the UFC.....	88
1.5.5	Air-to-Air Intraflight Data Link	90
1.5.6	Air-To-Ground Intraflight Data Link.....	94
1.5.7	IDM Use Scenarios.....	97
1.5.8	IDM Operational Considerations	98
1.6	RADAR WARNING RECEIVERS.....	99
1.6.1	General information and default modes of operation.....	99
1.6.2	BAE Systems (Loral) AN/ALR-56M	102

1.6.3	Raytheon (Litton) AN/ALR-69(V)	104
1.6.4	Raytheon (Litton) AN/ALR-93(V)1	106
1.6.5	Thales Airborne Systems Carapace.....	109
1.6.6	Raytheon (Litton) AN/ALR-67(V)3	112
1.6.7	Elisra SPS-1000V-5	114
1.7	ALE-47 COUNTERMEASURES DISPENSER SET	115
1.7.1	CMDS Modes	116
1.7.2	CMDS Programs	116
1.7.3	EWS DED Upfront Controls.....	117
1.8	LANTIRN	119
1.8.1	AN/AAQ-13 Navigation Pod (NVP)	119
1.8.2	AN/AAQ-14 Targeting Pod (TGP)	120
1.9	TERRAIN FOLLOWING RADAR (TFR)	121
1.9.1	Terrain Following Radar MFD Page	122
1.9.2	TFR Operating Modes and Options	123
1.9.3	TFR Confidence Display	125
1.9.4	TFR Controls.....	126
1.9.5	TFR Modes	127
1.9.6	Cautions, Warnings and Advisories	128
1.9.7	Fly-ups / Rollouts	134
1.9.8	TFR Procedures	135
1.10	AN/AAQ-33 SNIPER XR ADVANCED TARGETING POD	137
1.10.1	Background	137
1.10.2	TGP Base and Control pages for Sniper XR ATP.....	137
1.10.3	FLIR Sensor.....	138
1.10.4	Laser Designator/Ranger	140
1.10.5	IR Pointer	143
1.10.6	Sniper XR ATP Controls and Displays.....	145
1.10.7	Pod Modes.....	146
1.10.8	AGM-65 Hand Off	153
1.10.9	Miscellaneous Symbology	153
1.10.10	Additional Notes	156
1.10.11	Operational Considerations.....	157
1.11	HELMET MOUNTED CUEING SYSTEM (HMCS).....	160
1.11.1	Control Pages.....	160

1.11.2	Hands-On HMCS Blanking.....	161
1.11.3	HMCS Dynamic Aiming Cross.....	161
1.11.4	Air-to-Air Operations	162
2	AIR-TO-AIR-COMBAT	163
2.1	When Should You Chuck Your Spears?.....	163
2.1.1	A Bit of Theory	163
2.1.2	AIM-120 modes of operation	164
2.1.3	HUD Symbology: The Dynamic Launch Zone (DLZ)	164
2.1.4	HUD Symbology: ASEC/ASC	167
2.1.5	HPRF vs. MPRF, A/F-pole cues and Missile Datalink	168
2.1.6	Tactics - Some Basics	170
3	AIR-TO-GROUND.....	171
3.1	SPI MANAGEMENT	171
3.1.1	Introduction.....	171
3.1.2	SPI Description.....	171
3.1.3	System Delta and its effect on INS/EGI (Embedded GPS/INS)	172
3.1.4	Cursor Zero (CZ).....	174
3.1.5	Snowplow Mode	174
3.1.6	A-G Radar and SPI.....	174
3.1.7	Targeting Pod (TGP) and SPI	174
3.2	AGM-65D/G MAVERICK MISSILE	175
3.2.1	AGM-65 Operational Limitations.....	177
3.2.2	AGM-65 Time Limitations.....	177
3.2.3	HOTAS Functions	178
3.2.4	AGM-65 Base Page OSB Functions	179
3.2.5	SMS E-O WPN Control/Data Entry Pages	180
3.2.6	Electro-Optical Weapon (E-O WPN) Page.....	181
3.2.7	E-O Delivery	187
3.2.8	Targeting Pod E-O Delivery (Handoff)	194
3.2.9	AGM-65D/G Missile Boresight Procedures	196
3.3	AGM-88 HARM	199
3.3.1	SMS Base Page.....	200
3.3.2	HARM Modes.....	200
3.3.3	POS Mode	201
3.3.4	HAS Mode	209

3.3.5	HARM Attack Display (HAD)	211
3.3.6	New GS (Geographic Specificity) and TI (Target Isolate) implementation	216
3.3.7	HOTAS Controls Summary	221
3.4	INERTIALLY AIDED MUNITIONS	222
3.4.1	JDAM.....	222
3.4.2	WCMD.....	222
3.4.3	JSOW	223
3.4.4	SDB.....	223
3.4.5	Laser JDAM	224
3.4.6	IAM SMS Pages	225
3.4.7	Weapon Delivery Submodes	233
3.4.8	Impact Option (JSOW, WCMD).....	235
3.4.9	Impact Spacing (JSOW, WCMD).....	236
3.4.10	Target Profile Data Sets (JDAM)	236
3.4.11	HUD Symbology for IAM Weapons Delivery.....	239
3.4.12	IAM Weapon Release Considerations	243
3.4.13	JSOW, JDAM, SDB, WCMD PRE Weapons Delivery Procedures	244
3.4.14	JSOW, JDAM, WCMD VIS Weapons Delivery Procedures.....	245
3.4.15	Guide on IAM usage.....	246
3.4.16	SPICE Bomb.....	251
3.4.17	LGMs – Laser Guided Missiles	256
3.5	Laser Guided Bombs (LGBs).....	258
3.5.1	LGB SMS page	259
3.5.2	LGB CNTL page.....	259
3.5.3	LASER UFC PAGE.....	260
3.6	Man-in-the-Loop Weapons	261
3.6.1	General Information	261
3.6.2	SMS Page	264
3.6.3	WPN Page	265
3.6.4	Man in the Loop Hands-On Controls	271
3.6.5	HUD.....	272
3.6.6	HSD	273
3.6.7	Weapon Release Procedure	274
3.7	AGM-84 Harpoon.....	275
3.7.1	SMS Base Page.....	275

3.7.2	WPN Page	276
3.7.3	Harpoon HUD.....	277
3.7.4	RBL – Range and Bearing Launch Mode	278
3.7.5	BOL – Bearing Only Launch Mode	279
3.7.6	LOS – Line Of Sight Launch Mode	279

0.1 LIST OF FIGURES

Figure 1	F-16 HOTAS Throttle (TQS) and Stick (SSC) Controls	16
Figure 2	FCR NOT SOI Display	22
Figure 3	VIP Sighting	28
Figure 4	VRP Sighting.....	29
Figure 5	AUX COMM Panel.....	31
Figure 6	IFF panel.....	31
Figure 7	Backup TACAN MFD page	32
Figure 8	T-ILS (TACAN-ILS) DED page.....	32
Figure 9	HOTAS Throttle (TQS) and Stick (SSC) Controls	36
Figure 10	FCR Multi-Function Display.....	38
Figure 11	FCR Mode page.....	39
Figure 12	FCR BIT test	41
Figure 13	FCR OVRD.....	42
Figure 14	HUD NO RAD display.....	43
Figure 15	FCR NOT SOI.....	43
Figure 16	CHK FCR CONTROL PAGE message	44
Figure 17	B-scope	45
Figure 18	FCR CNTL page	47
Figure 19	Expanded Target Data (left) and FCR in COAST (right)	48
Figure 20	FCR DCLT	49
Figure 21	Merged Bullseye and Steerpoint Symbols.....	50
Figure 22	FCR Azimuth Limits	51

Figure 23 FCR Elevation Scan Limits (left) and Antenna Elevation Scan Coverage (right)	52
Figure 24 SAM Azimuth Scan Width vs Range	53
Figure 25 Tracked Target Symbology	55
Figure 26 CATA	56
Figure 27 ESD & SAD	57
Figure 28 Spotlight Search	58
Figure 29 RWS NORM and EXP Display	59
Figure 30 NCTR	59
Figure 31 A-A HOTAS TMS functions (FCR SOI)	61
Figure 32 TWS (left) and TWS with bugged/priority target (right)	64
Figure 33 STT	66
Figure 34 ST SAM entry > auto SAM (left) and DT SAM > DTT submode (right)	68
Figure 35 ACM 30° x 20°	71
Figure 36 ACM Boresight	72
Figure 37 ACM 10° X 60°	73
Figure 38 ACM Slewable	74
Figure 39 A-A HOTAS TMS functions (FCR SOI) ACM specifics highlighted	75
Figure 40 Air-to-Air FCR Symbology	76
Figure 41 Air-to-Ground (GM mode) Display	77
Figure 42 Auto Range Scale Switch Points	78
Figure 43 GM FOV options (clockwise from top left: NORM, EXP, DBS1 and DBS2)	79
Figure 44 FTT display	84
Figure 45 HSD Data Link Symbology	87
Figure 46 Data Link Initialization Pages	89
Figure 47 All IDM addresses filled and displayed on FCR and HSD	89
Figure 48 Friendly wingmen off HSD (bottom left)	90
Figure 49 Assignee (#3's) FCR, HSD and HUD	92
Figure 50 Data link Switch Summary	94
Figure 51 Assignee (#3's) HSD and HUD showing data linked Markpoint	94
Figure 52 Assignee (#3's) FCR, HSD and HUD. Assigner (#1) sent cursor data NNE of ownship Markpoint	96

Figure 53 CMS Switch	115
Figure 54 CMDS Cockpit Control Unit (CCU)	115
Figure 55 DED EWS Pages.....	117
Figure 56 FLIR image in MFD and HUD	119
Figure 57 TFR MFD Page	121
Figure 58 TFR Operation	122
Figure 59 TFR in STBY.....	123
Figure 60 TFR in WX mode.....	124
Figure 61 TFR Confidence Display	125
Figure 62 ADV Mode Switch	126
Figure 63 TFR HUD warnings	129
Figure 64 LANTIRN AAF CHECK ATTITUDE	132
Figure 65 Sniper XR Base Page	137
Figure 66 Sniper XR Control Page	138
Figure 67 Laser DED page	140
Figure 68 Laser Mode & Code and Laser/IR Pointer Status Indications.....	140
Figure 69 Laser/IR Pointer Status On HUD	141
Figure 70 IR Pointer Indications.....	143
Figure 71 Laser Codes on the DED Page	147
Figure 72 Laser Spot Track Selection	147
Figure 73 Laser Track Display	148
Figure 74 LST Indications in the HUD	149
Figure 75 Point Track Display	150
Figure 76 TGP in A-A Mode.....	151
Figure 77 TGP TD Box in HUD – TGP in A-A Mode.....	151
Figure 78 Area Track Display	152
Figure 79 AGM-65 Handoff Status.....	153
Figure 80 Situational Awareness Indicator	154
Figure 81 CHECK ATTITUDE on MFD.....	155
Figure 82 On/Off Brightness Control Switch	160

Figure 83 Level 1 / Level 2 / Level 3.....	161
Figure 84 HUD cues related to STPT position.....	173
Figure 85 AGM-65 Maverick.....	175
Figure 86 LAU-117/A and LAU-88A/A launchers (above).....	176
Figure 87 LAU-88A/A and LAU-117/A launchers (below).....	176
Figure 88 AGM 65 Base Page (SMS EO WPN page).....	179
Figure 89 Electro-Optical Weapon (E-O WPN) Page.....	182
Figure 90 Electro-Optical Weapon (E-O WPN) Page.....	182
Figure 91 AGM-65D/G keyhole.....	184
Figure 92 AGM-65 crosshair and blanking area	185
Figure 93 Track Polarity	186
Figure 94 AGM-65 Preplanned Delivery HUD Cues.....	187
Figure 95 AGM 65 Visual EO Delivery HUD Cues.....	188
Figure 96 EO Delivery HUD Cues	189
Figure 97 AGM-65 LOS HUD Cue	190
Figure 98 AGM-65 accurate vs. inaccurate ranging.....	192
Figure 99 AGM-65G Force Correlation Track	193
Figure 100 POINT track - TGP attempts handoff (HANDOFF IN PROGRESS shown on WPN page).....	195
Figure 101 Handoff Complete (also indicated with C above station number on WPN page).....	195
Figure 102 LOS with successful handoff	196
Figure 103 AGM-88 HARM	199
Figure 104 HARM SMS page	212
Figure 105 HAD MFD page.....	213
Figure 106 GBU-31(v)1/B JDAM	222
Figure 107 CBU-105 SFW	223
Figure 108 AGM-154A JSOW	223
Figure 109 GBU-39 SDB	224
Figure 110 GBU-54 Laser JDAM	224
Figure 111 JDAM SMS base page	225
Figure 112 JDAM SMS control page	225

Figure 113 WCMD SMS base page	226
Figure 114 WCMD SMS control page	226
Figure 115 JSOW SMS base page.....	227
Figure 116 JSOW SMS control page.....	227
Figure 117 GBU-39 SDB SMS base page	228
Figure 118 GBU-39 SDB SMS control page	228
Figure 119 Laser JDAM SMS base page	229
Figure 120 Laser JDAM SMS control page	229
Figure 121 Laser JDAM SMS control page 2	230
Figure 122 TXA counts down alignment status	232
Figure 123 IAM delivery submodes weapon flight path profiles	234
Figure 124 JSOW and WCMD impact geometries	235
Figure 125 JSOW EGEA and ROB	238
Figure 126 JDAM/WCMD/JSOW PRE/VIS-Post-Designate and JSOW MPPRE HUD steering and release cues	241
Figure 127 Predefined steerpoints location	241
Figure 128 JDAM DED page	248
Figure 129 JDAM SMS page	249
Figure 130 Spice Bomb	251
Figure 131 Weapon target selection	251
Figure 132 SPICE DED page.....	252
Figure 133 SPICE SMS page	254
Figure 134 SPICE LAR2 Scale.....	255
Figure 135 AGM-123 Skipper II.....	256
Figure 136 LGM SMS page.....	256
Figure 137 GBU-10 Paveway II.....	258
Figure 138 GBU-24 Paveway III	258
Figure 139 GBU-27 Paveway III	258
Figure 140 GBU-12 Paveway II.....	258
Figure 141 GBU-15.....	261
Figure 142 AGM-84H SLAM-ER.....	262

Figure 143 Man-in-the-Loop SMS page	264
Figure 144 Man-in-the-Loop WPN page - Strapped	265
Figure 145 Man-in-the-Loop WPN Control page - Strapped	265
Figure 146 Man-in-the-Loop WPN page - Airborne.....	268
Figure 147 Generation 0/1 Airborne WPN page	268
Figure 148 Man-in-the-Loop WPN page – Generation 3/4 – Ground Stabilized.....	270
Figure 149 Man-in-the-Loop WPN page – Generation 2 – Ground Stabilized	270
Figure 150 Man-in-the-Loop Weapon HUD.....	272
Figure 151 Man-in-the-Loop Weapon HSD	273
Figure 152 AGM-84A Harpoon	275
Figure 153 Harpoon SMS Page	275
Figure 154 Harpoon WPN Page	276
Figure 155 Harpoon HUD Symbology	277

0.2 LIST OF TABLES

Table 1 Master Mode Selection.....	21
Table 2 Steerpoint assignments	23
Table 3 Display Coordinate Systems by Radar Mode	39
Table 4 FCR Faults.....	85
Table 5 ALR-56M Buttons and Indicators	101
Table 6 TFR RF Control available modes.....	126
Table 7 TFR Warnings / Cautions / Advisories chart	131
Table 8 TFR Faults	133
Table 9 Sniper XR ATP Controls	145
Table 10 TXA values for the different IAMs.....	233
Table 11 Data Link Pods and supported MITL weapons.....	262
Table 12 Man in the Loop Hands-On Controls	271



1 AVIONICS SYSTEMS AND CONTROLS

1.1 COCKPIT CONTROLS AND DISPLAYS

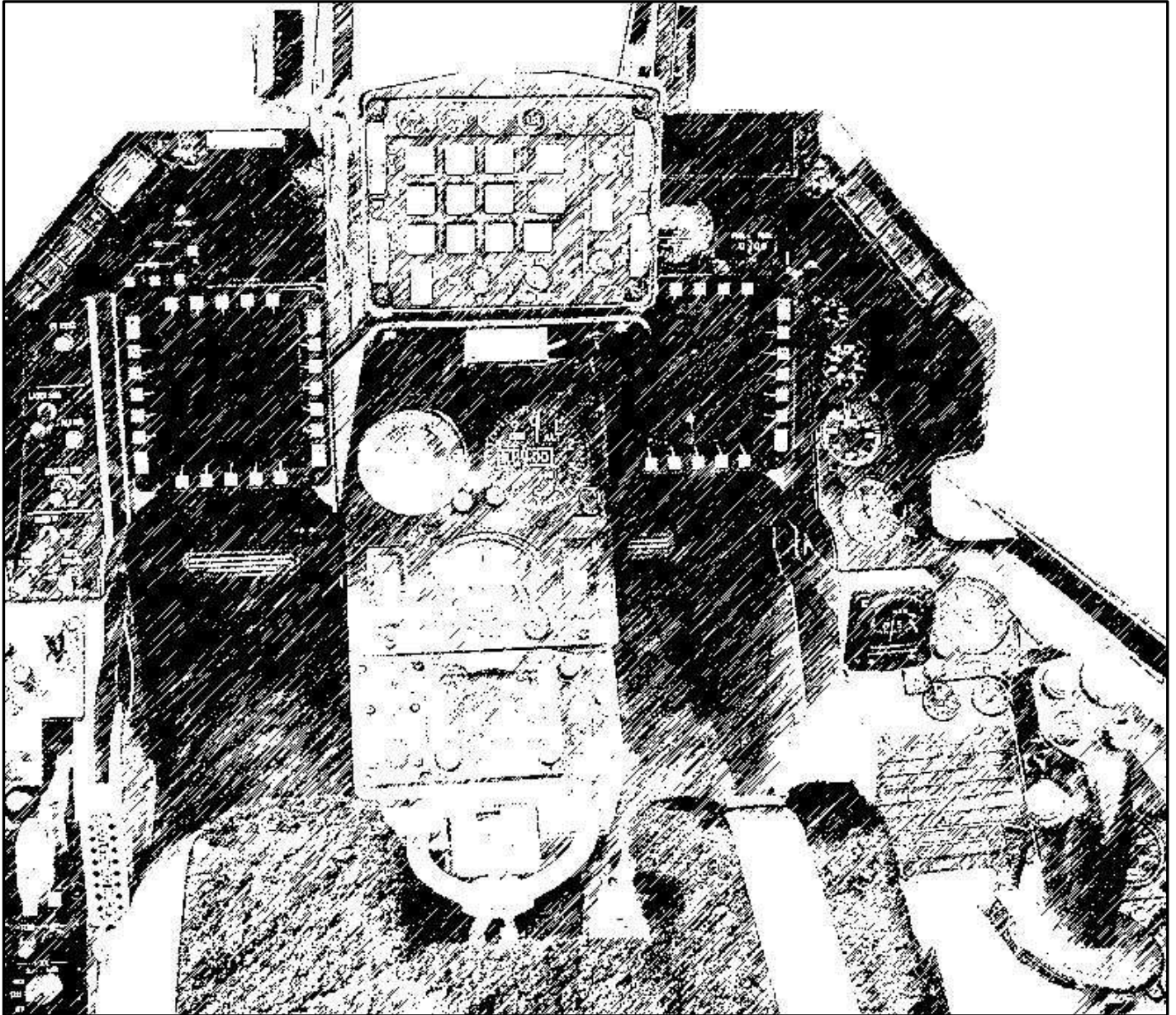

This section describes the location and function of the weapon system related controls and displays. Its purpose is to provide a quick reference guide to finding or using the system described in this manual.

When applicable, this section will contain a reference to the place that the system is described in detail.

1.1.1 Philosophy of Cockpit Controls and Displays

The F-16 avionic system incorporates master mode, cursor control and sensor-of-interest (SOI) features designed to integrate controls and displays and simplify display and sensor management. For this section, the cockpit controls and displays are categorized as follows:

- Key Avionic Console Switches.
- Upfront Controls.
- Video Displays.
- Hands-On Controls.

The layout of the cockpit is designed to afford the operator the greatest flexibility in system mode, sensor and weapon selection while optimizing efficiency of movement in the cockpit and thereby reducing pilot workload.

The avionic system allows the pilot to prepare preplanned set-ups for modes, sensors and weapons; either automatically or manually before takeoff. These preplanned set-ups let the pilot utilize the hands-on controls, Multifunction Displays, Upfront Controls, and Head-Up Display/Helmet Mounted Cueing System so that a minimum amount of time is spent looking inside the cockpit.

1.1.1.1 *Key Avionic Console Switches*

Console panels are positioned so that those switches which can be set during ramp start and then forgotten are located on the right console, out of sight. Consoles which affect specific mission completion (i.e. communications, navigation, landing gear) are grouped together for easy access in flight and generally located on the left console.

1.1.1.2 *Upfront Controls*

Upfront Controls (UFC) consist of the Integrated Control Panel (ICP), the Data Entry Display (DED) and Pilot Fault List Display (PFLD). The UFC consolidates and automates the communication, navigation and identification (CNI) functions. The UFC set is partitioned between frequently used controls on the ICP and infrequently used controls on the side consoles. Frequently used controls such as override and priority functions are accessed via a single push-button on the ICP.

1.1.1.3 *Video Displays*

Two Colour Multifunction Displays (MFD's), a Head-Up Display (HUD) and a Helmet Mounted Cueing System (HMCS) provide the pilot with essential mission information for head-down and head-up operations.

The MFD's are intended to allow common operation and control of various subsystems and sensors as well as provide video display for the radar, weapons, targeting pod and Navigation pod.

The HUD allows the pilot to monitor both navigation and weapon delivery information and still remain focused outside the aircraft.

The HMCS is an electro-optical device that displays information in front of the pilot's right eye; it is intended primarily for daytime operation. The HMCS also provides the pilot with the ability to cue the aircraft sensor suite and weapons outside the HUD field of view (FOV) and provides feedback to the pilot on sensor and weapon data. The HMCS is basically an extension of the HUD, and as such they are considered as one SOI (i.e. they share the same Hands-On Control switchology).

1.1.1.4 Hands-On Controls

The hands-on controls consist of switches located on the throttle grip and the side-stick controller. Functions that require instantaneous access (e.g., radio transmit, target designate, weapon release) and functions that must be accomplished during maneuvering flight, when the pilot cannot remove his hands from the stick and throttle, are controlled by the hands-on controls.

The following diagrams illustrate the typical F-16 HOTAS control grips and the various functions assigned to them. With the exception of the black-out switch (HOB0), all HOTAS functions are modelled in the game.

The sections which follow illustrate the functionality of the various controls in A-A and A-G modes and provide the names of the key file callback names that are typically mapped to each switch position on the stick and throttle grips. They should be referred back to as necessary.

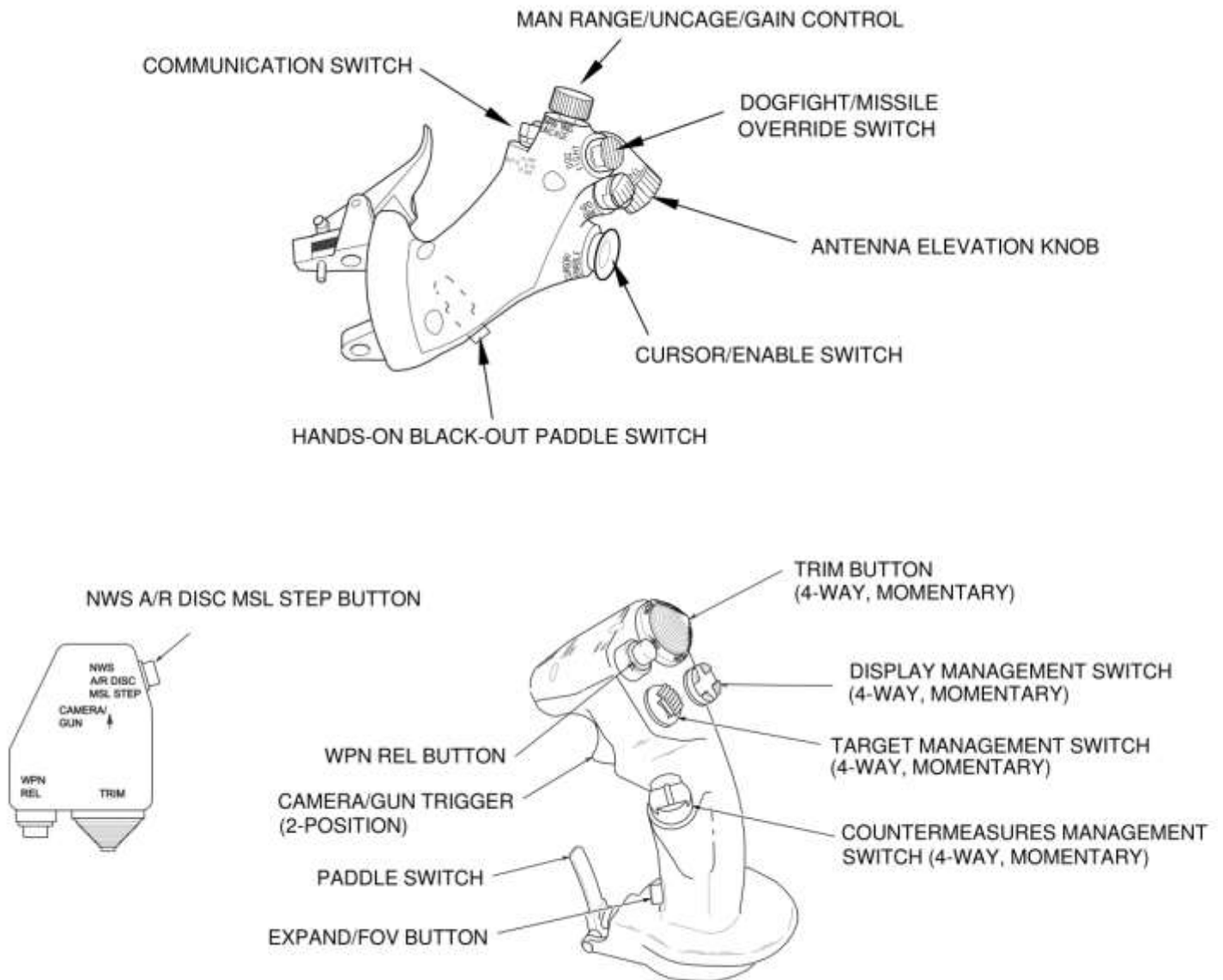
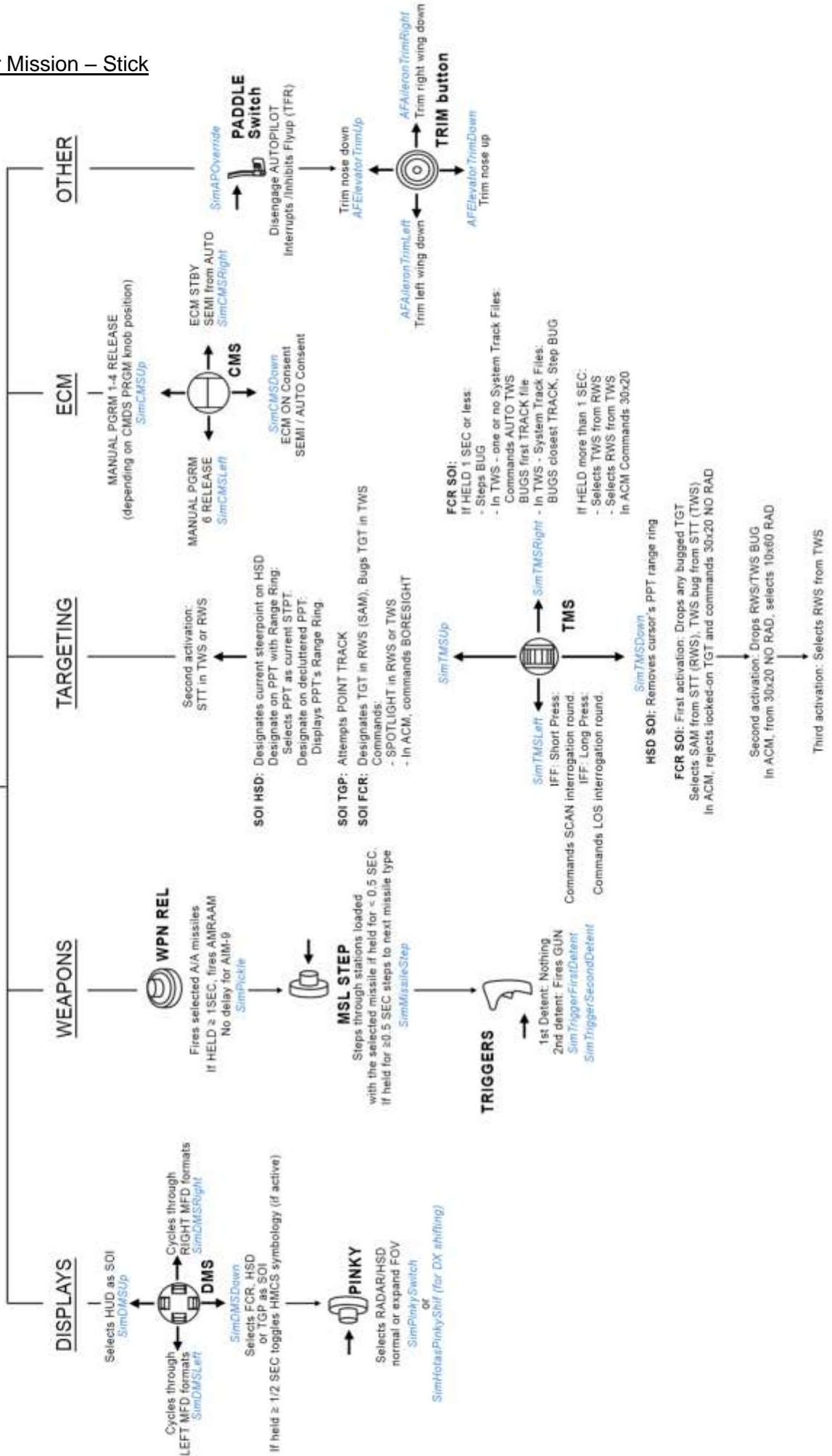

Figure 1 F-16 HOTAS Throttle (TQS) and Stick (SSC) Controls

1.1.1.4.1 Air-to-Air Mission – Stick

**HANDS-ON CONTROLS
AIR TO AIR MISSION
SIDE STICK CONTROLLER
A-A, MSL OVRD, DGFT**



1.1.1.4.2 Air-to-Air Mission - Throttle

**HANDS-ON CONTROLS
AIR TO AIR MISSION
THROTTLE
A-A, MSL OVRD, DGFT MASTERMODE**

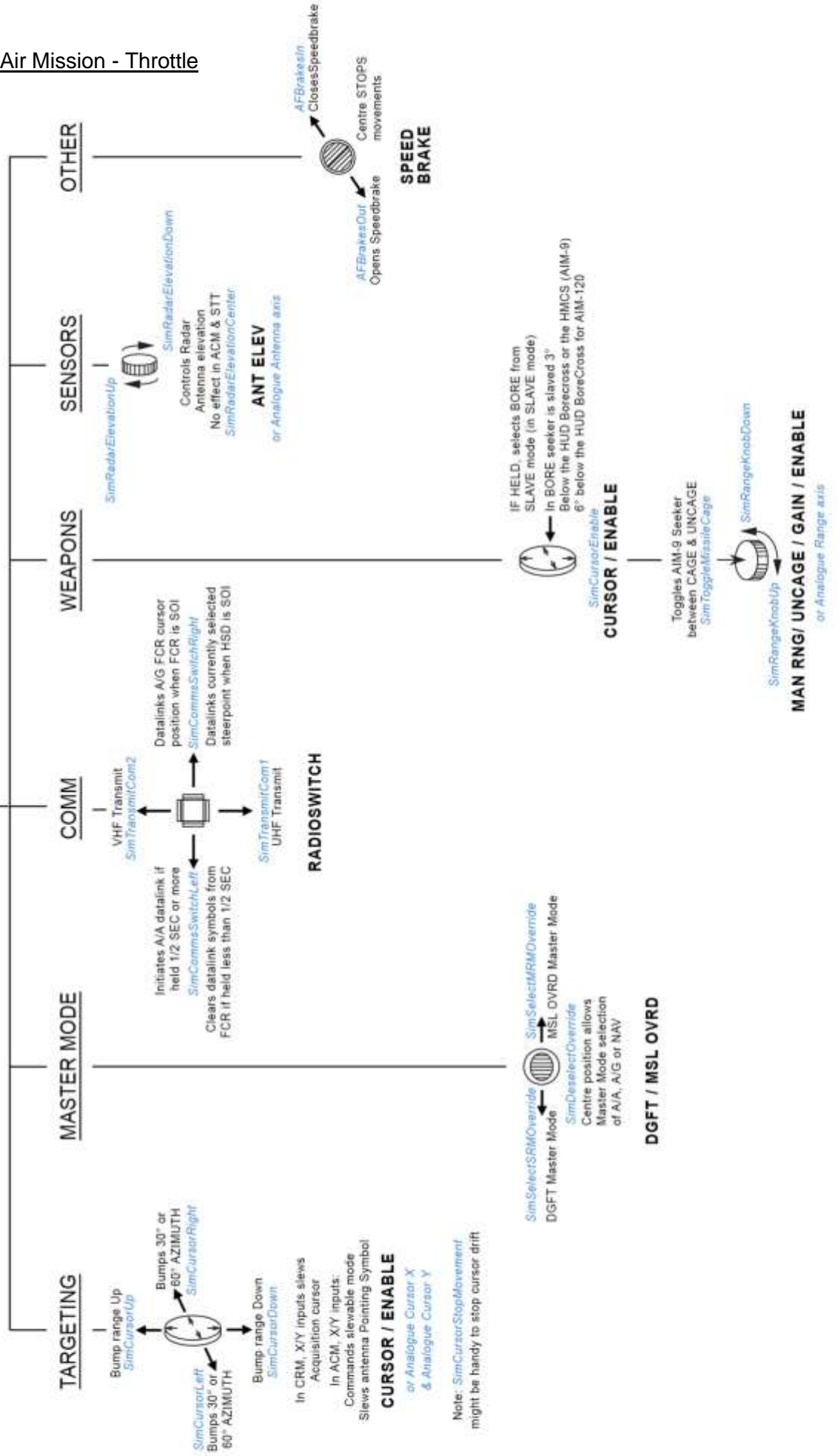

1.1.1.4.3 Air-to-Ground Mission – Stick

**HANDS- ON CONTROLS
AIR TO GROUND MISSION
SIDE STICK CONTROLLER
A-G (& NAV) MASTERMODE**

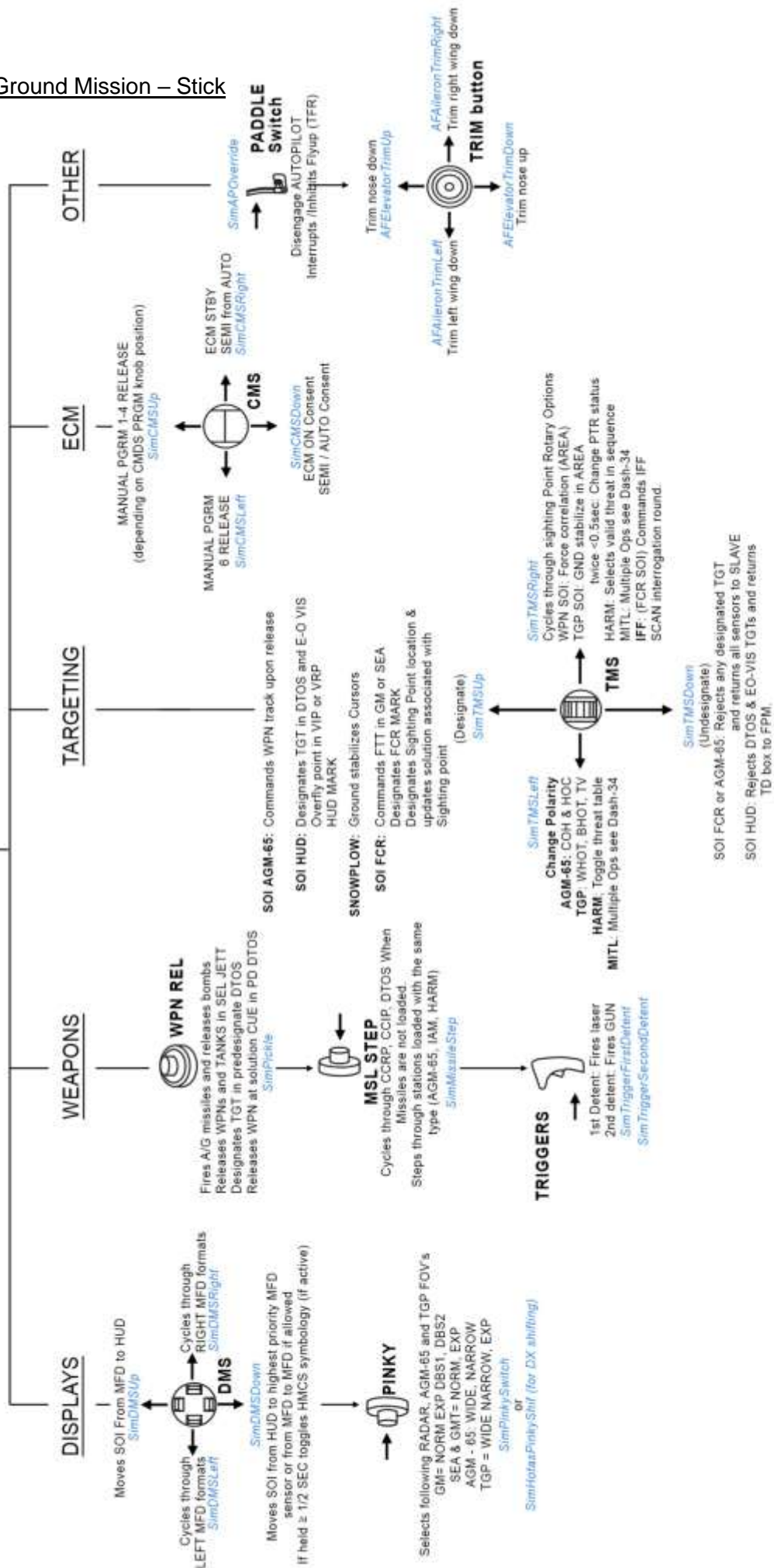

1.1.1.4.4 Air-to-Ground Mission - Throttle

**HANDS-ON CONTROLS
AIR TO GROUND MISSION
THROTTLE
A-G (& NAV) MASTERMODE**

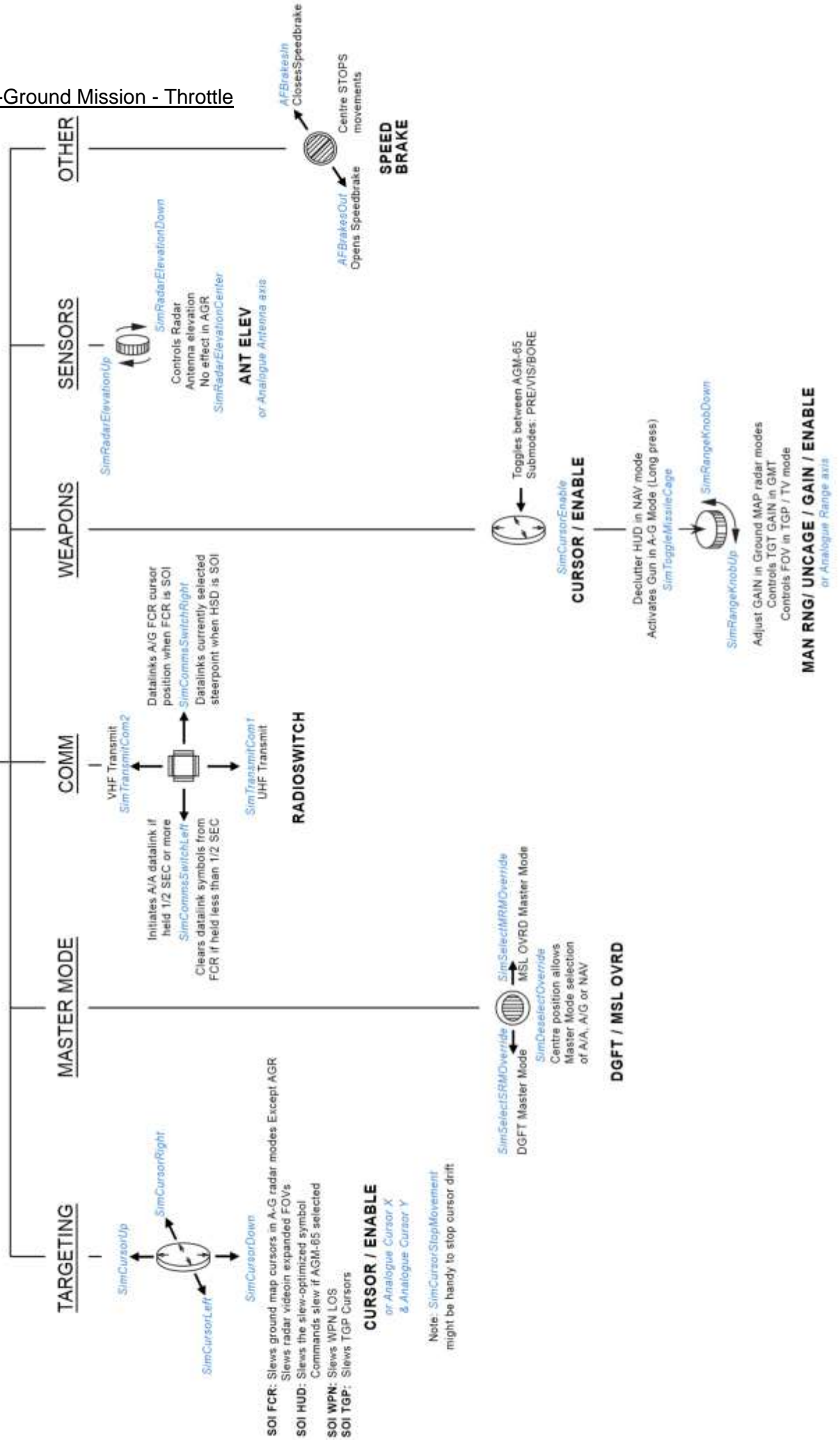

1.1.2 F-16 Mode and Sensor Concepts

1.1.2.1 Master Mode Selection and Control

The F-16 allows a master mode to be rapidly selected with a single switch action; thus configuring the avionics suite and the cockpit controls and displays for a particular mission. Table 1 provides a list of the master modes and their respective switch locations and positions. All the master modes, except Emergency Jettison, can be preprogrammed to a desired set of conditions. Master mode configurations can be programmed into the Data Transfer Cartridge (DTC) in the UI during mission planning, or set up with [Weapon Delivery Planner](#). The master modes are automatically configured when the DTC is loaded into the aircraft via the DTE MFD page. Upon exiting the current master mode, the last master mode table is updated with any changes you have made. If necessary, the master modes may also be programmed manually using the master mode switches and the Multifunction Display Set (MFDS) menus.

Table 1 Master Mode Selection

MASTER MODE	SWITCH LOCATION	SWITCH POSITION
Dogfight	Throttle	DGFT (left/outward)
Missile Override	Throttle	MSL OVRD (right/inward)
Emergency Jettison	Landing Gear Panel	EMER STORES JETTISON button
Air-to-Air	ICP	A-A button
Air-to-Ground	ICP	A-G button
Selective Jettison	SMS MFD pages	OSB 11 (S-J)
Navigation		Default if no other Master Mode selected

The Emergency Jettison master mode will override all other master modes. Pressing the Emergency Jettison button on the landing gear panel will command jettison of all air-to-ground stores while retaining all air-to-air weapons and pods. After jettison is complete, the system should return to the previously selected master mode.

Dogfight and Missile Override master modes will override any selected master mode except Emergency Jettison. When Dogfight or Missile override is selected, the master mode will be configured with the options saved to the DTC or manually during ramp start. If the DTC is not programmed or used, the master mode will be default configured. Dogfight is selected by positioning the Dogfight/ Missile Override switch on the throttle grip to the outboard position. Missile Override is selected by positioning the Dogfight/Missile Override switch to the inboard position.

The Air-to-Air, Air-to-Ground, Navigation, or Selective Jettison master modes may be selected when the Dogfight/ Missile Override switch is in the centre position. Air-to-Air and Air-to-Ground master modes are selected by depressing either the A-A button or the A-G button, respectively, on the ICP. The Selective Jettison master mode is selected using any of the Stores Management Set (SMS) mode pages. The Navigation master mode is selected by deselecting the current master mode with the Dogfight/Missile Override switch in the centre master mode. When the Dogfight/Missile Override switch is repositioned to the centre position from Dogfight or Missile Override positions, the avionic system will return to the last selected master mode when the switch was in the centre position.

1.1.2.2 System Point-of-Interest (SPI)

F-16 sensor management is based on a single line-of-sight concept where all sensors are slaved to a common aimpoint, referred to as the System Point-of-Interest (SPI). Please see 3.1 SPI MANAGEMENT for more details.

1.1.2.3 *Sensor-of-Interest (SOI)*

SOI mechanization simplifies multiple sensor management by designating one sensor format for hands-on control.

If the SOI is the HUD/HMCS, the SOI asterisk symbol is positioned on the upper left of the HUD. If the SOI is an MFD, the SOI symbol consists of a line drawn around the edge of the MFD. SOI designation is a function of either the highest priority sensor or of pilot intent.

Examples of pilot intent include:

- If the Display Management Switch (DMS) is moved up, the SOI designation transitions to the HUD, if allowed.
- If the HUD is the SOI and the DMS is moved down, the SOI designation transitions to the MFDs.
- If the DMS is moved down and the SOI is on the MFDs, then the SOI transitions to the other MFD, if allowed.
- If the SWAP OSB on an MFD is depressed, the SOI symbol follows the sensor display to the other MFD.

The SOI cannot be designated in the MARK OFLY submode, or the snowplow (SP) function in the pre-designate (PRE) state.

Only FCR, TGP, WPN, HAD, and HSD formats may be the designated SOI display on the MFD. The HUD may be the designated SOI only in the navigation and air-to-ground master modes. The SOI display is restricted in the air-to-air master mode to the FCR, HSD and TGP formats.

On the FCR, TGP, HSD, HAD and WPN formats, NOT SOI appears whenever the format is not selected as the sensor of interest.



Figure 2 FCR NOT SOI Display

Please refer to the companion T.O. BMS1F-16CM-1 manual (Dash 1) for general information on Cockpit Arrangement, Up Front Controls, Multi-Function Displays and the Head Up Display. Specific information about cockpit controls and displays relevant to describing aircraft avionics, weapons systems, support equipment and munitions will be covered later in this manual.

1.2 INERTIAL NAVIGATION SYSTEM (INS)

1.2.1 Steerpoints

There are 1-99 possible steerpoints (STPTs). They are broken down as follows:

Table 2 Steerpoint assignments

STPT#	Usage
1-24	Navigation route / general flight planning
25	Bullseye (automatically assigned)
26-30	Ownship MARK points – small “x” (inverse video if selected)
31-54	HSD lines (4 lines with up to 6 points in each line)
56-70	Preplanned threats (PPTs saved to DTC during preflight planning)
71-80	Datalink MARK points – large “X” (inverse video if selected)
81-89	Open
90-99	Open / HARPOON waypoints

Steerpoint numbers 1-24 are regular flight planning ones for use in the Campaign or TE mission planning screen for an aircraft’s flight plan. Numbers 26-30 are reserved for MARK points created by the pilot.

The pilot may go to the Bullseye DED page (LIST 0 8) and select any steerpoint from 1-25 as bullseye, however the ‘normal’ campaign/TE bullseye is stored in STPT 25 by default. If the pilot chooses another steerpoint other than 25, AI aircraft and AWACS will *still* continue to use the BE as set by the campaign engine (i.e. the coordinates in STPT 25). Being able to select a specific steerpoint as your Bullseye is more useful for TE missions with human pilots involved, like Force on Force.

Note also that since all steerpoints can be edited in the STPT or DEST DED pages, you can overwrite your copy of the campaign Bullseye — be careful! For similar reasons, **do not** make flight plans with more than 24 STPTs.

STPT AUTO mode no longer wraps at the last STPT that is designated as part of your flight plan. The ▲ ▼ arrows on the ICP will get you to any STPT from 1-99 as opposed to just those on your flight plan. Cycling to steerpoints not assigned will show all 0s in the latitude/longitude fields.

HSD lines now have up to 6 points available per line (it was 5 previously), with 4 lines available.

1.2.2 DED pages

INS related DED pages include the STPT, DEST, and BULLSEYE. For a more comprehensive explanation of Up Front Controls please refer to the companion T.O. BMS1F-16CM-1 manual (Dash 1).

1.2.2.1 DED Steerpoint Page



Punching “4” on the ICP brings the pilot to the Steerpoint (STPT) page. The scratchpad asterisks will initially be at the top as seen above. The pilot may punch another number (4, ENTR) to select a different steerpoint as the current steerpoint. All steering cues will update to reflect the new selection (#4 in this example).

The pilot may “Dobber” down with the Data Control Switch (DCS) to each individual field on the page and edit it as desired: latitude, longitude, elevation and Time on Station (TOS). Note that while editing lat/long, the pilot will see immediate feedback from his steering cues (tadpole, STPT diamond, ETE/ETA, bearing/distance, etc.) in the HUD and in heads-down displays since the STPT he is editing is the current steerpoint. Elevation may be edited as well and it now functions like the real aircraft, i.e. it is the MSL elevation of the steerpoint at ground level. This is automatically set by the campaign/TE flight plan generator for any steerpoints set up in the UI.

The pilot may also toggle auto steerpoint sequencing (AUTO) on/off (MAN) by dobbering right (towards SEQ) on the steerpoint DED page. With auto steerpoint sequencing the system will automatically increment the steerpoint when the aircraft is within 2Nm of the steerpoint and the range is increasing. Auto steerpoint sequencing is indicated on the CNI page with a letter “A” displayed next to the current steerpoint. Nothing is displayed in manual.

1.2.2.2 DED Destination Page



The Destination (DEST DIR) DED page is nearly identical to the STPT page. The only difference is that the DEST page can be used to change coordinates of a particular steerpoint without affecting navigation to the current steerpoint.

1.2.2.3 DED Bullseye Page

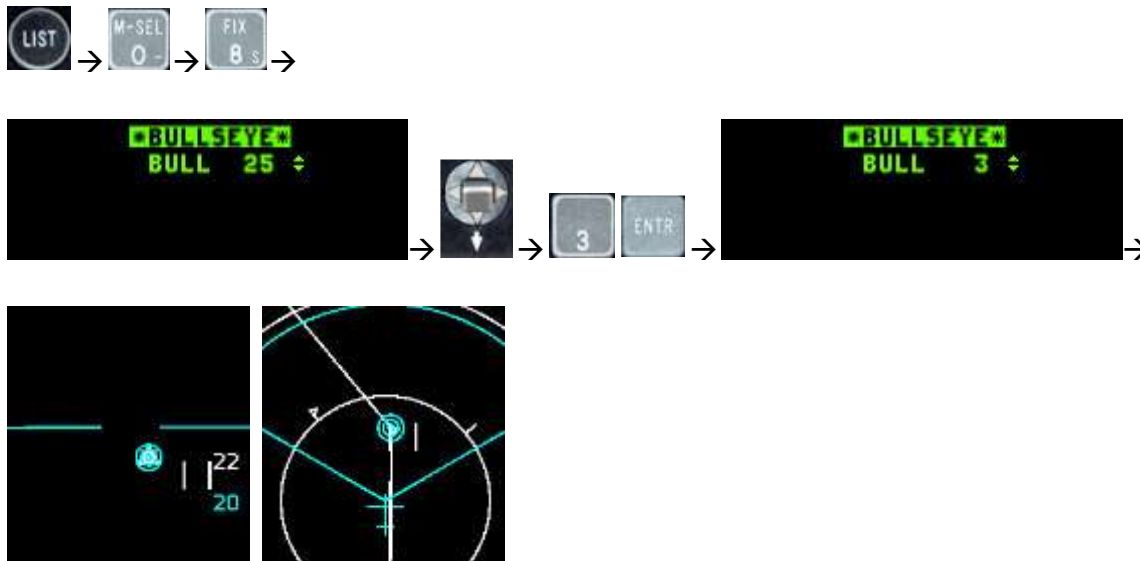

As mentioned above the default Bullseye steerpoint is #25. Bullseye can be changed to any steerpoint. In the example above, Bullseye is changed to STPT 3 and the pilot sees STPT and Bullseye co-located on the FCR and HSD.

Remember: the AI and AWACS will only use the location that is stored in STPT 25 and that the pilot has the possibility of overwriting this location, so be careful.

1.2.2.4 DED Time Page

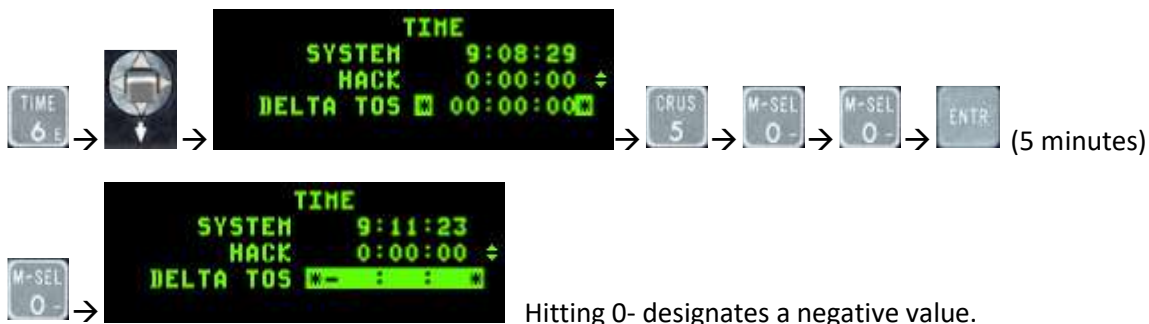

The Time page includes the system time, a hack clock time and a delta time on station. The hack clock may be started or stopped by using the ▲▼ switch. The DELTA TOS value allows you to adjust TOS to all destinations with one entry, to accommodate changes in takeoff and/or rendezvous times.

Dobber down to the DELTA TOS field and enter the delta time to any steerpoint. If required, press the 0- key prior to your entry to designate it as a negative value (i.e. you want to arrive earlier at all steerpoints). Press ENTR to apply the DELTA TOS to all TOS.

1.2.2.5 **DED MARK Points**

When entering DED MARK page (ICP 7) the MARK mode will be set automatically according to the Master Mode and relevant sensor state.

- **FCR** - If the system is in NAV or AG master modes, the FCR is in AG mode (not AGR), the FCR is the SOI and the FCR is designating something, MARK mode will be automatically set to FCR. When entering MARK page at this state, a FCR MARKPOINT will be recorded when you TMS Up.
- **TGP** - If the system is in NAV or AG master modes, the TGP is in AG mode, the TGP is the SOI and ground stabilized, MARK mode will be automatically set to TGP. When entering MARK mode at this state, a TGP MARKPOINT will be recorded when you TMS Up.
- **OFLY** - If the system is in AA master mode, MARK mode will be automatically set to OFLY. When entering MARK mode at this state, an OFLY MARKPOINT will be recorded immediately. No TMS Up is needed.
- **HUD** - If the system is in NAV or AG master modes and conditions are not sufficient to set FCR or TGP modes, MARK mode will be automatically set to HUD and a HUD Mark Cue (HMC - a 12mr circle with a 1mr aiming dot inside it) will appear on the FPM in the HUD. This is pre-designate mode.

The HMC can be cursor-slewed to the desired position and TMS Up ground stabilizes it (post-designate mode). The position may be refined using the cursors and then a second TMS Up will save the Markpoint.

In post-designate with the HMC ground stabilized, a TMS Down will cancel the stabilization and return to pre-designate mode, and the HMC will again be tied to the FPM. Note that if trying to ground stabilize or mark with TMS Up when the cue is not on the ground, nothing will happen.

If you select a MARK mode with the ICP sequence (SEQ) button which does not match the current system and sensor state (for example setting FCR MARK when the system is in AA master mode), an OFLY MARKPOINT will be recorded when you TMS Up.

When the MARK DED page is displayed and the current MARKPOINT is valid (has positional data) then depressing the M-SEL button (ICP 0) will set that MARKPOINT as the current active steerpoint.

The MARK mode rotary will cycle through the 4 existing modes in this order: HUD, TGP, OFLY, and FCR. When the MARK DED page is displayed and one of the 1-9 ICP buttons is pressed, a MARK mode change will happen (just like using the sequence button).

A Markpoint is just like any other steerpoint and can be sent to another aircraft via the IDM.

1.2.3 Sighting Options

Aircraft sensors are pointed along a common line-of-sight (LOS) to a specific point on the ground for air-to-ground sighting known as the System Point-of-Interest (SPI). The following sighting options and cursor position features are available:

STP/TGT –	Steerpoint and Target Direct Aimpoint sighting
OA1/OA2 –	Offset Aimpoint sighting
IP –	Visual Initial Point sighting
RP –	Visual Reference Point sighting
SP –	Snowplow sighting

The STP/TGT, OA1/OA2, IP, and RP sighting options are selected via the sighting point rotary on the MFD GM FCR page (OSB 10). Additionally the sighting point options are selectable via TMS right. Offset (OA1/OA2), initial point (IP) sighting, and reference point (RP) sighting are used for aim points where positions are known or estimated to be near specified steerpoints. Bearing from true north, range, and elevation data are entered via the upfront controls. *Note: For simplification, entering “0” for elevation places offsets at ground level, regardless of terrain MSL altitude. Thus, pilots should normally enter “0” for altitude.*

1.2.3.1 Direct Aimpoint Sighting (STPT/TGT)

Direct sighting can be used in any bombing mode. All sensors are pointed at the selected steerpoint. Slewing the cursor via the cursor control may be required to place the steerpoint position over a desired aim point more precisely. Slew corrections may be zeroed via the cursor zero OSB.

1.2.3.2 Offset Aimpoint Sighting (OA1/OA2)

Steerpoints may have up to two offsets, each defined as a true bearing and range from the steerpoint and each with a separate elevation. If an offset aim point has zero range, it is skipped in the sighting point rotary. If OA1 or OA2, all sensors are pointed to the offset position; however, the steerpoint defines the target location. As a result, weapons may be delivered against a target that presents a poor radar return by aiming at a radar-significant object. Offset aim point sighting is provided in preplanned submodes (CCRP in this case, since LADD and ULFT are not implemented) only. The OA symbol is an isosceles triangle 12 mr high and 6 mr wide. It is displayed in NAV and A-G mastermodes.

Offset aim point selections are remembered by the system through master mode and steerpoint changes.

1.2.3.3 Visual Initial Point Sighting (VIP)

Visual initial point (VIP) sighting is used in preplanned submodes to plot a target on the HUD at a true bearing and range from a visually identifiable overfly point. Overfly updates to the SPI and HUD slews are not implemented at this time.

The VIP sighting mode also allows for an unknown target position to be referenced from a known position (steerpoint) during a mission. By preplanning the IP, bearing, and range, and elevation can be entered while airborne to define the target.

While in VIP, navigation steering to the IP is provided via the HSI and the azimuth steering line to the target on the HUD. Cursor zero reverts the system solution back to the original navigation solution if cursor slews are made. Bearing, range and elevation data for the IP may be entered by pressing LIST→3 on the ICP. VIP is mode-selected by placing the scratchpad asterisks on "VIP-TO-TGT" and pressing "0" to mode select. Offset aim points and IP sighting may be used simultaneously.

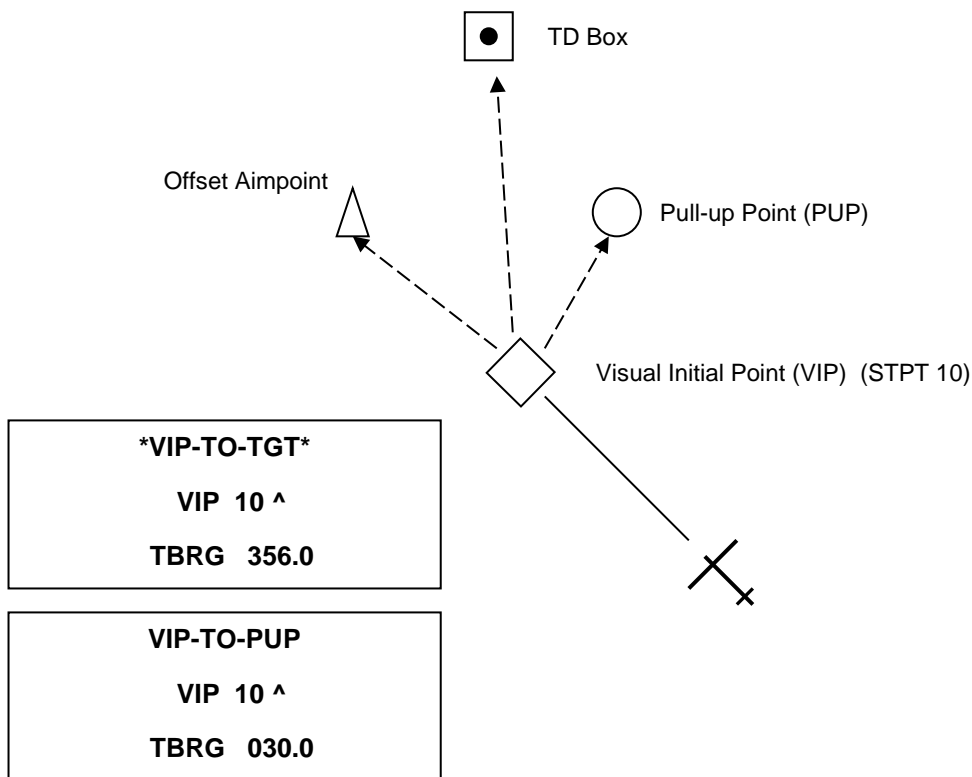

Figure 3 VIP Sighting

1.2.3.4 **Visual Reference Point Sighting (VRP)**

Visual reference point (VRP) sighting mode is used in preplanned submodes to plot a reference point on the HUD as a true bearing and range from the target. This allows the utilization of a known, visually identifiable position, or RP point, to initiate an attack. Again, overly updates to the SPI and HUD slews are not implemented at this time.

While in VRP, navigation steering is provided to the target via the HSI and via the azimuth steering line on the HUD. Initially, the sighting point rotary is on TGT. While in VRP, the steerpoint defines the target and the RP is defined as a bearing and range from the target and an elevation (remember, use "0"). Bearing, range and elevation data for the RP may be entered by pressing LIST→9 on the ICP. VRP is mode-selected by placing the scratchpad asterisks on "TGT-TO-VRP" and pressing "0". Offset aim point and RP sighting are available simultaneously.

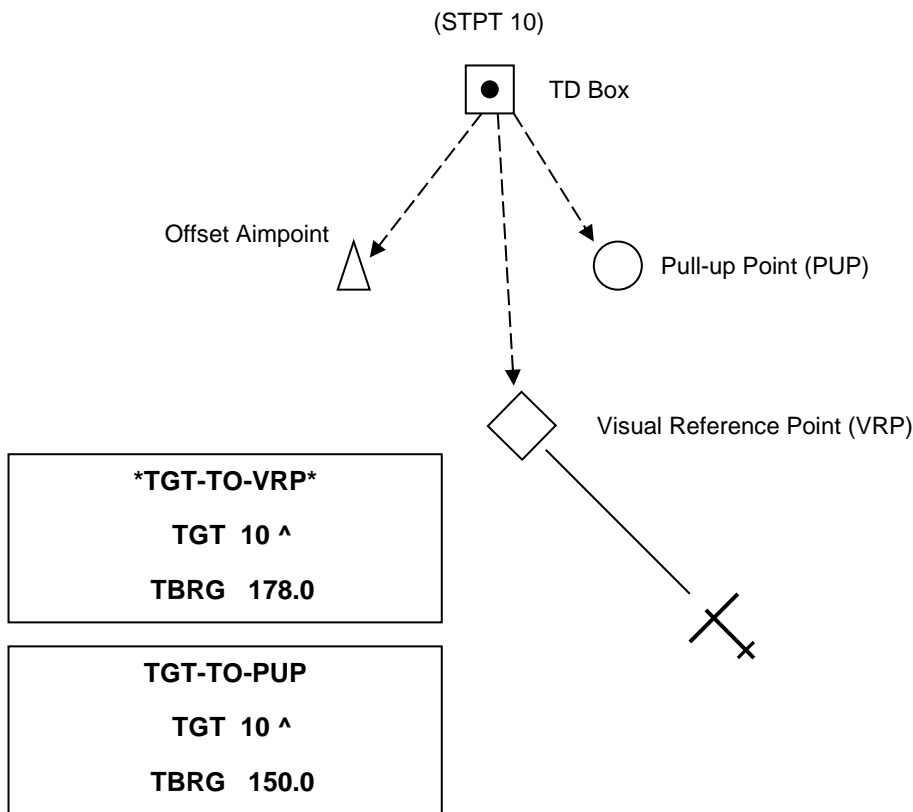

Figure 4 VRP Sighting

1.2.3.5 *Pop-Up Point (PUP) Cue.*

The pop-up point (PUP) is entered via the VIP-TO-PUP or VRP-TO-PUP page of the DED. DCS right (SEQ) to select the PUP page from the VIP or VRP pages. When the PUP is limited in the HUD FOV, an X is superimposed over it.

1.2.3.6 *Final IP and RP Notes*

Note how aim points and PUPs are defined in both VIP and VRP (they are always off the steerpoint—the VIP is a steerpoint while the VRP is not). Careful study of the geometry in both modes will ease understanding and help the pilot make the decision in which mode would be best utilized. Target type, location, terrain features and delivery methods may also be factors to consider when using one mode or the other. VIP and VRP may not be used simultaneously. Mode-selecting one will de-mode-select the other. It is not advisable to try and use both modes for one steerpoint as OA and PUP geometry will change if one mode is selected but the offsets were intended for (or entered in) the other.

1.2.3.7 *Snowplow (SP) Sighting*

Depress OSB 8 next to the SP mnemonic in GM/GMT to select the snowplow option. The mnemonic highlights indicating that you are in the SP mode. SP sighting directs each sensor line-of-sight straight ahead in azimuth, disregarding any selected steerpoints. In the GM, GMT, and SEA modes, the ground map cursor will be positioned at half the range selected, i.e., the centre of the MFD. The cursors remain at this range while the ground map video moves, or "snowplows," across the MFD. At this point, there is no SOI, and the cursors cannot be slewed. The cursors can be slewed to a target or aim point with the CURSOR/ENABLE switch **after** you **ground stabilize** them by using **TMS forward**.

TMS forward establishes the radar as the SOI and enables cursor slewing. TMS forward again over a target to command single target track. All cursor slews in SP are zeroed when SP is deselected. After ground stabilizing, the point under the cursors at the time of stabilization effectively becomes your steerpoint. All NAV and weapon delivery steering and symbology, including great circle steering, will be referenced to this "pseudo steerpoint." Displays return to the previously selected sighting point when SP is deselected. For example, SP can be used to accomplish an FCR mark on a point 5 NM in front of your position when the steerpoint selected is 40 NM away. It may often be used with IR Mavericks where target coordinates are not known in advance.

1.3 TACAN

TACAN means TACTical Air Navigation and is primarily a military navigation aid. It essentially combines two navigation systems (but with differences) from civilian air navigation: VOR (VHF Omni directional Range) and DME (Distance Measuring Equipment). Often, a VOR and a TACAN are combined into a unique system called a VORTAC. Usually, only military airbases are equipped with TACAN, but since it is the only navigational aid we have in Falcon, civilian VORDMEs & VORTACs in the real Korea have been associated with TACANs in Falcon.

TACAN is a radio signal (UHF 960-1215 MHz) and as such depends on Line of Sight. That means if a mountain is between your aircraft and the TACAN station, your instrument will not be able to receive the signal. You will get longer TACAN range when flying at high altitude. When down in the weeds the TACAN signal will probably be degraded because of the limited line of sight.

TACANs are set with a channel (from 0 to 126) and a band (X or Y) (252 channels total) and an operating mode, air-to-ground or air-to-air (T/R and A/A TR). The F-16 has two ways to set the TACAN system: One primary and one backup.

The backup system is set through the AUX COMM panel where the channel, band and mode are set and will work as long as the CNI switch is set to BACKUP.



Figure 5 AUX COMM Panel

Newer or upgraded blocks may have an IFF panel instead. On these panels backup TACAN controls have been replaced by backup IFF controls and the CNI switch is now labelled C&I.



Figure 6 IFF panel

In these jets backup TACAN controls have a dedicated MFD page. It is advisable to set this up during ramp start in case you lose both MFDs during the mission.



Figure 7 Backup TACAN MFD page

The primary way to set up TACAN is the UFC (Up Front Controller) and is used as soon as the CNI / C&I switch is set to UFC. On the ICP T-ILS sub-page, enter the channel in the scratchpad, press M-SEL/0 to toggle the band (X or Y) and DCS right to toggle the mode (T/R or A/A TR).



Figure 8 T-ILS (TACAN-ILS) DED page

1.3.1 Air-to-Ground Modelling

TACAN can be used in both air-to-ground (A-G) and air-to-air (A-A). A-G obviously is used for tuning a ground navigation station and using it to navigate your airplane to/from a fixed ground location. Currently in BMS all ground stations are in the X TACAN band. Refer to the charts (in the \Docs\03 KTO Charts folder) for specific TACAN channels.

To tune into a ground station, simply input the TACAN channel and band into your navigation system and set your HSI to TACAN mode. If the TACAN is in range and within line of sight, all relevant information on the instrument will be relative to that ground station.

1.3.2 Air-to-Air Modelling

Aircraft are also equipped with TACAN emitters as in real life. Depending on the type of aircraft, only distance information or both distance and bearing are transmitted. In Falcon BMS, only the KC-10 has both; all the other aircraft (F-16 included) are only able to transmit range information via DME (Distance Measuring Equipment).

A-A TACAN is a little bit more complicated than A-G. The channels between the two coupled aircraft need to be 63 apart. The maximum allowed channel is 126, one way or another. So if you want to tune into another aircraft that is on channel 11, you need to input channel 74 ($11+63=74$). If the other aircraft is on channel 80, you will have to set channel 17 ($80-63=17$). You can't set $80+63=144Y$ as that's over the 126 limit. In A-A mode the band can be X or Y, but the mode needs to be set to A/A TR.

When two aircraft are tied with A-A TACAN, the DME information appears in the DME window of the HSI and on the lower right corner of the DED if the A-A TACAN signal is valid. The bearing pointer on the HSI (set to TCN) will spin at $30^\circ/s$ when no bearing information is received, or will point to the direction of the emitter when receiving bearing information (KC-10 only).

In addition, regardless of HSI mode selection, if you put the TACAN in A/A TR mode, the DED CNI page will show you DME to the aircraft your TACAN is locked on to if one exists (either as XX.X if less than 100Nm range or XXX miles if greater). If you see "-----" instead, then you have selected a channel that has no partner aircraft to lock on to.

Humans can select any TACAN channel and any band for A-A TACAN. If more than one receiver is tied, only the DME range to the closest one will be displayed.

Example: Flight with #2 in Fighting Wing and #3 in Spread. Fighting wing is a visual formation and #2 does not really need A-A TACAN. The guy in spread might use an A-A TACAN though, especially in a simulated environment where judging distance on a flat screen might be a problem. So lead sets an A-A TACAN of 10Y and transmits that information to his flight members. If both #2 and #3 set their TACAN to 73Y ($10+63=73Y$), both will get the distance from their lead but lead will only get the distance from the closest tied aircraft. Obviously, that's #2, when he does not need to know the distance from his immediate wingman. To avoid that, lead and element lead can tie together and wingmen can tie together as well on a different TACAN channel/ band. It can be one channel apart or even better one band apart but on the same channel, e.g.: Lead (#1) on 10Y paired with Element Lead (#3) on 73Y and lead's wingman (#2) on 73X and element lead's wingman (#4) on 10X. That way, element leads are tied together and wingmen are tied together as well, but by simply changing the A-A TACAN band ($X \rightleftharpoons Y$); they can quickly make a check on their respective lead, or switch to those channels if the elements split to maintain better SA.

While humans can select any channel and band, AI aircraft use fixed TACAN channels in the Y band. The first AI flight will use: 12, 22, 75 & 85Y. The next AI flight is one number higher: 13, 23, 76 & 86Y. BMS can support up to five flights of AI with this system. That means that you can always find an AI controlled aircraft in the first 5 flights.

Refueling aircraft use fixed TACAN channels. The first tanker in the TE is assigned channel 92Y. This is the most "logical" tanker channel to use, because the reciprocal channel is easy to find: $92-63=29Y$ – the digits are simply reversed.

If there is more than one tanker in the TE, then the next one will default to 126Y, then 125Y and so on. To tie on them, pilots will set 63Y, 62Y, etc. You can always ask AWACS (if one is available) for a vector to the nearest tanker; the response will include the tanker's TACAN channel (and UHF frequency, position and several other bits of information very handy when you're getting low on gas), but remember that the operator in the AWACS will always give you the TACAN channel that you need to enter in your UFC to tie with the tanker.

Finally note that you can operate the up-front controls (ICP/DED) TACAN settings and those will govern the operation of your on board TACAN as long as the AUX COMM panel CNI (or IFF panel C&I) switch is in "UFC". If the switch is in "BUP" then the TACAN settings on the AUX COMM panel (or TCN MFD page for IFF panel aircraft) will be used for TACAN operation. This can come in handy if you want to switch quickly between two separate aircraft. There is still only one TACAN transceiver available though.

1.4 AN/APG-68(V)5 FIRE CONTROL RADAR



1.4.1 Background

The AN/APG-68(V)5 fire control radar (FCR) is a multimode, digital sensor designed to provide all-weather air-to-air and air-to-ground modes with dogfight and weapons delivery capabilities. Introduced with F-16 C/D Block 50/52 aircraft (and export specific variants) it is a descendent of the AN/APG-68(V)1 fitted to Block 40/42 aircraft, the AN/APG-68 (Block 25 and onwards) and the AN/APG-66 family of radars that were used in earlier F-16 A/B and MLU versions.

The air-to-air modes detect and track targets at forward aspects of maximum $\pm 60^\circ$ off boresight in elevation and $\pm 60^\circ$ off boresight in azimuth at all altitudes, either in the clear or with ground clutter.

Target data in the air-to-air modes is presented as synthetic video on a B-scope display. Air-to-ground modes provide mapping and navigation as well as target detection, location, and tracking.

1.4.1.1 *Radar Theory*

Air-to-Air radar detects aircraft by emitting radio frequency (RF) energy in a narrow beam and then detecting RF energy reflected by the target.

Low frequency is more effective for long range detection but requires large, heavy equipment. High frequency has shorter range capacity but higher accuracy needed for targeting and requires smaller, lighter equipment.

Transmissions are sent out in pulses so that the transmitter and receiver can share one antenna. The APG-68 antenna is a mechanically scanned phased array design driven by electric motors and gimballed in two axes. It provides coverage of 120° in azimuth and in elevation.

Pulse Recurrence/Repetition Frequency (PRF) is the number of pulses of RF that are transmitted every second. The APG-68 has low, medium and high PRF capability. Low PRF is best for long range detection. High PRF is better for accuracy at the expense of range.

Pulse radars detect targets by detecting the raw returns from these transmissions and display everything in raw video with no filtering. These images require skill to interpret and targets are easily lost in look-down situations due to ground clutter masking the real target return.

Doppler shift is a small change in RF frequency as a result of relative motion between a transmitter and target which can be used to calculate velocity.

Pulse Doppler radars, such as the APG-68 rely on a Doppler filter and reject targets below a set speed threshold called the Moving Target Reject (MTR). Doppler Effect is also used to filter out ground returns so that returns with closure similar to aircraft groundspeed are not displayed. This creates a small range of masked closure rates around aircraft groundspeed called the Doppler Notch. The real APG-68 has selectable notch values.

Pulse Doppler radars have a high resistance to chaff as target detection is based on relative velocity. Chaff once dispensed decelerates rapidly as it disperses and is quickly rejected by the Doppler filter.

Pulse Doppler radars are however susceptible to beaming when the perceived closing velocity of a target can fall below the threshold set by the filter.

Target range is calculated by measuring the time between transmission and reception of RF energy.

The position of the radar antenna, both in azimuth (left/right) and elevation (up/down), is used to determine the position of the target(s).

1.4.2 FCR Controls

1.4.2.1 HOTAS

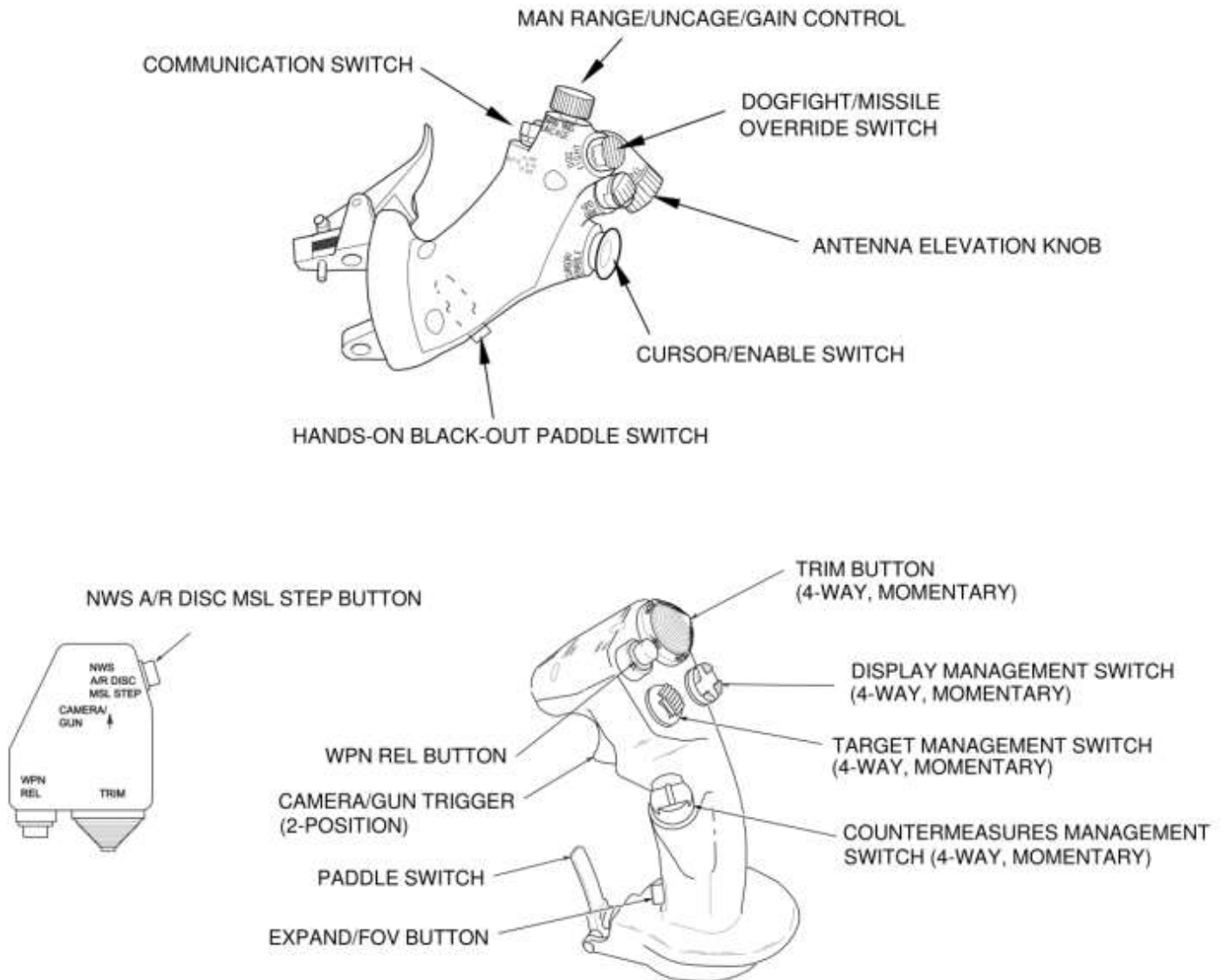

Figure 9 HOTAS Throttle (TQS) and Stick (SSC) Controls

1.4.2.1.1 Manual Range/Uncage/Gain (MAN RNG/UNCAGE) Control

Operation of the MAN RNG/UNCAGE control is a function of the system mode. In ground-map (GM) modes, the gain knob controls radar map gain. Rotating the knob clockwise or counterclockwise increases or decreases the gain, respectively.

1.4.2.1.2 Antenna Elevation (ANT ELEV) Knob

The ANT ELEV knob provides manual control of antenna elevation. Rotating the knob clockwise or counter-clockwise from the 0° detent position causes the antenna scan centre to move upward or downward to the maximum antenna

elevation limit of $\pm 60^\circ$. Antenna elevation angle can be manually adjusted in A-A search modes. In A-G mapping modes, the tilt control offsets the antenna tilt angle from MMC commanded cursor position. The knob has no effect in radar track modes.

1.4.2.1.3 Communication Switch

The A-A FCR B-scope may be decluttered of IDM symbology by a Communication switch left for less than 0.5 seconds. The display will remain decluttered until Comms switch left <0.5 secs is toggled again.

1.4.2.1.4 DOGFIGHT/MRM Override Switch

The three-position DOGFIGHT/MRM override switch provides a hands-on override of all master modes except emergency jettison. The DOGFIGHT, or outboard, position provides both gun firing and missile delivery. The missile override, or inboard, position provides missile delivery only. Any air-to-air radar mode may be programmed for either switch position.

1.4.2.1.5 RDR CURSOR/ENABLE Control

The multidirectional tilt feature of the CURSOR/ENABLE switch controls cursor slewing on the SOI display. Because the throttle grip slides forward, down, backward, and up to control engine thrust, controller deflection is more accurately described with respect to the position of the base of the thumb. For example, tilting the switch to the left of the base of the thumb moves the cursor on the SOI display to the left. The cursor control portion of the CURSOR/ENABLE control allows A-G cursor slewing in normal fields of view, video slewing in expanded fields of view, acquisition cursor slewing in A-A FCR modes, and scan slewing in slewable ACM.

1.4.2.1.6 EXPAND/FOV Button

The EXPAND/FOV button is used to select available expanded or alternate FOVs for the SOI by stepping through the selectable options.

1.4.2.1.7 Display Management Switch (DMS)

The DMS, which is spring-loaded to the centre position, controls SOI selection and format (MFD page) stepping.

1.4.2.1.8 Target Management Switch (TMS)

The spring-loaded TMS controls target designation and data on the FCR display according to master mode (A-A, A-G), radar mode and submode. Master mode specific information is detailed below.

1.4.2.2 **Sensor Power (SNSR PWR) Panel**

The SNSR PWR panel is located on the forward section of the pilot's right console and contains four ON/OFF switches. The third switch from the left, labelled FCR, applies power to the Fire Control Radar.

1.4.2.3 **Quiet / Silent Switch**

The FCR will not emit RF energy if the RF Mode switch is moved to Quiet or Silent in BMS. NO RAD is displayed in the HUD when the MMC silences the FCR Transmitter.

1.4.2.4 FCR MFD - Multi Function Display

The multi-function display is the primary interface to the radar and is used to select radar modes and parameters. The MFD features the following:

- 20 Option Select Buttons (OSB) aligned along the borders
- 4 Rocker Switches (GAIN, SYM, CON, BRT)

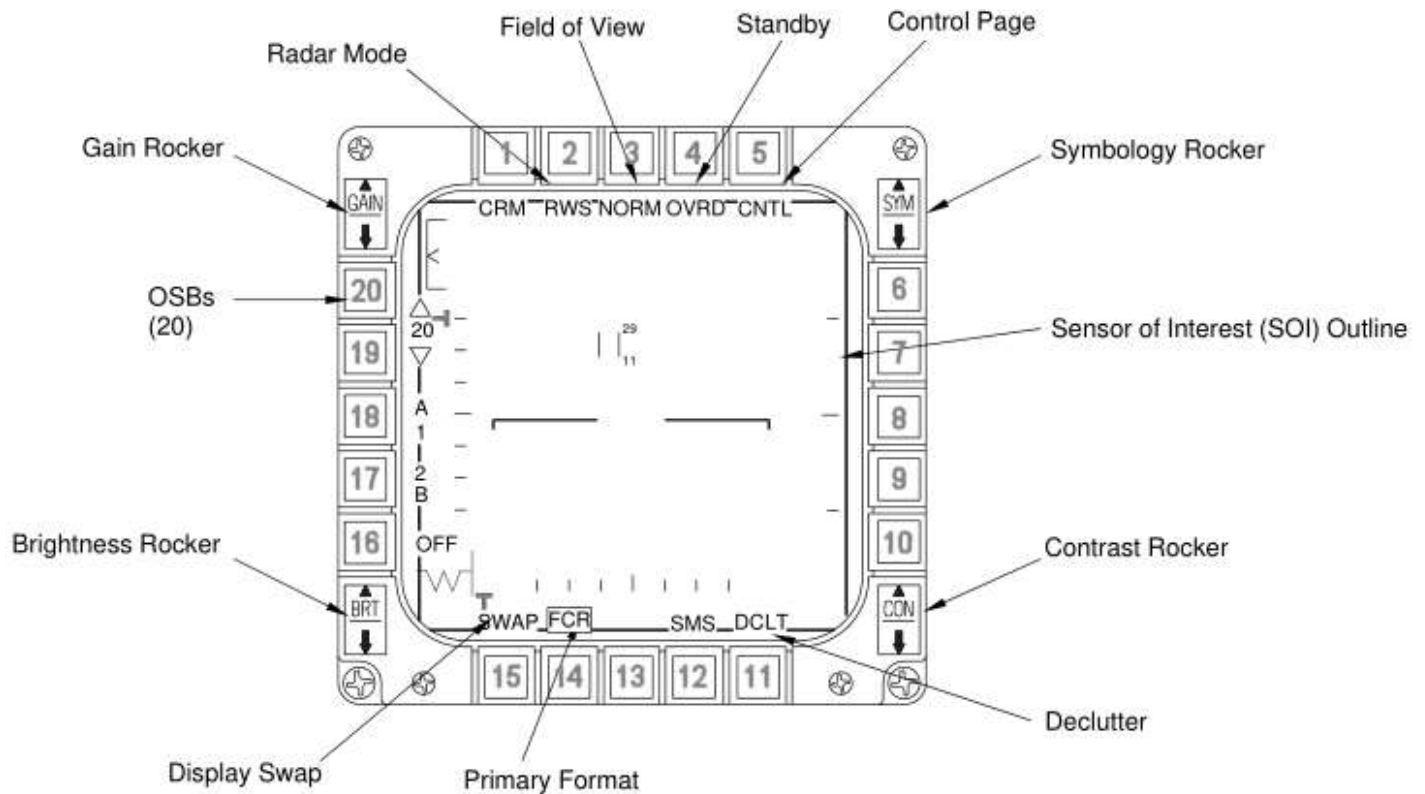

Figure 10 FCR Multi-Function Display

1.4.2.4.1 Display Coordinate Systems

There are three coordinate systems used by the radar displays and the antenna scan pattern generator: Space Stable, Drift Stable, and Body Stable.

In a Space Stable system the elevation and azimuth angles are relative to the horizon and aircraft heading respectively and are independent of ownship pitch and roll. When the tilt is set to 0°, for example, the antenna will scan parallel to the earth about the ownship heading regardless of the pitch and roll angles of the aircraft.

In a Body Stable system, like ACM 30x20, the azimuth and elevation angles are relative to the aircraft body axis and the scan patterns will follow the aircraft as it pitches and rolls.

A Drift Stable system is very similar to the Space Stable system in that it too is roll and pitch independent except that the azimuth angle in a Drift Stable system is relative to the platform azimuth angle of the velocity vector and not the aircraft heading. The centre of the display at 0° azimuth in a Drift Stable system represents the velocity vector which may be 10° in a Space Stable system when the drift angle is equal to 10°.

Table 3 Display Coordinate Systems by Radar Mode

Radar Mode	Coordinate System
RWS, ULS, VSR, SAM, TWS, STT	Space Stable
30x20, 10x60, Boresight	Body Stable
Sleuable ACM	Space Stable
GM, SEA, DBS	Drift Stable
FTT	Drift Stable
AGR	Space Stable

1.4.2.4.2 Rocker Switches

There are four rocker switches located on the corners of the MFD: Gain (GAIN), Brightness (BRT), Contrast (CON) and Symbology (SYM). Only GAIN and BRT are implemented in BMS.

1. GAIN. The Gain rocker switch is used to control the radar gain in Air-to-Ground modes in BMS.
2. BRT. The BRT rocker adjusts the display intensity.

1.4.2.4.3 Option Select Buttons (OSBs)

The twenty OSBs surrounding the MFD are programmed to perform specific control functions for each sensor. Each function is identified by a mnemonic displayed adjacent to the appropriate OSB. When an OSB is depressed its mnemonic will flash momentarily to provide feedback. The left and right MFD pages may be swapped via the button adjacent to the SWAP button. Depressing the DCLT button will remove selected button labels from the MFD.

1.4.2.4.4 Radar Mode Page

Depressing the button adjacent to the radar mode indicator accesses the radar mode menu page and displays radar modes available for the selected master mode. The FCR Mode Menu is shown below.

All radar modes except AGR and BIT are available in the NAV Master Mode. Depressing the FCR mode OSB accesses the selected mode and returns to the basic FCR format page. FCR A-A or A-G modes can be selected before takeoff, via the FCR mode menu page, or simply loaded from the Data Cartridge (DTC). During flight the mode menu page may be selected without interrupting the present FCR operating mode. Whenever communication between the MFDs and FCR is missing FCR OFF is displayed in the centre of the MFD.

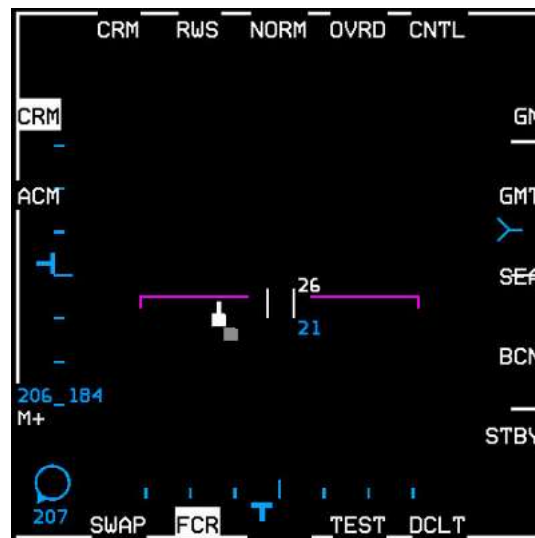

Figure 11 FCR Mode page

1.4.3 Radar Modes

1.4.3.1 FCR Formats

The FCR format (page) provides radar video, controls and status as a function of one of the following FCR modes:

- Standby (STBY)
- Built-in test (BIT)

1.4.3.1.1 Air-to-Air Modes

The available air-to-air modes in BMS are:

- Combined Radar Mode (CRM):
 - Range-While-Search (RWS)
 - Situation Awareness Mode (SAM)
 - Single Target Track (STT)
 - Up-Look Search (ULS)
 - Velocity Search with Ranging (VSR)
 - Track-While-Scan (TWS)
- Air Combat Mode (ACM)

1.4.3.1.2 Air-to-Ground Modes

The available air-to-ground modes in BMS are:

- Ground map (GM)
- Fixed Target Track (FTT)
- Ground Moving Target (GMT)
- Sea (SEA)
- Beacon (BCN) (displayed on Menu page but not implemented)
- Air-to-Ground Ranging (AGR)

Depressing OSB 1 above the present mode mnemonic accesses the FCR mode menu page and displays the FCR modes available in the selected master mode. Depressing the OSB adjacent to the desired FCR mode deselects the current mode, accesses the selected mode and returns the display to the basic FCR format for that mode.

1.4.3.2 FCR Turn-On/Off

1.4.3.2.1 FCR Power-on

Before power can be applied to the FCR and other avionic subsystems, proper cooling from the Environmental Control System (ECS) must be present, i.e. ensure the AIR SOURCE knob position is set to NORM, otherwise the FCR will shut down automatically to avoid overheating. The MMC, MFDs and UFC should be operating prior to power-on.

The FCR format display page is accessed by depressing the FCR button on the basic MFD format and menu page or by depressing the highlighted primary format mnemonic on a MFD page other than the FCR page. Following FCR power application the FCR page will continue to display "FCR OFF" during the initial warm-up period (approximately 30 seconds after the application of power). The FCR then enters Built-In-Test (BIT) at Power-On.

1.4.3.2.2 FCR Power-off

Placing the FCR Power Switch to OFF will start a power down sequence. This sequence lasts for approximately four seconds. If the switch is returned to ON/FCR before four seconds has elapsed the FCR software is reinitialized in a quick restart; the FCR will enter a shorter BIT and the transmitter does not have to "time-out" (perform its usual 3 minute warm-up). The FCR will re-enter the mode in which it left before the FCR switch was momentarily turned off and assume initial default conditions.

1.4.3.3 BIT - Radar Built in Test

The AN/APG-68 performs a sequence of tests to alert for any FCR related problems. These tests, known as BITs, are a group of sequenced tests either automatically initiated at FCR power-on, referred to as BIT at Power-On (around 3 minutes), or manually initiated (via the TEST page), referred to as Pilot Selected BIT (approx. 30 seconds). BIT provides a thorough indication of operational system readiness.

During the BIT you can preset the desired antenna elevation and range (though the physical antenna remains stowed in the full up/left position) which will be selected as soon as you no longer have weight on wheels (WOW). If you leave the Power-On BIT to run its course the FCR will go to STBY mode after completion. If you press OSB 1 (BIT) while the Power-On BIT is running you can preselect the desired FCR mode from the Radar Mode page.

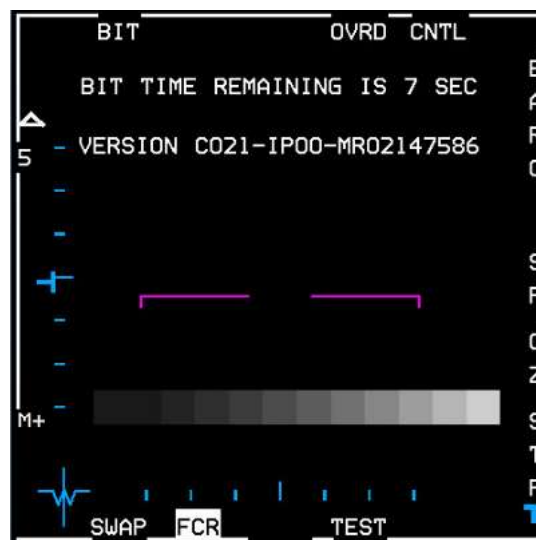

Figure 12 FCR BIT test

1.4.3.4 Standby (STBY)/Override (OVRD)

STBY is automatically entered after the completion of BIT (if no other mode has been selected). STBY mode can be manually selected by either of the following two methods:

1. From a FCR mode display, depress the OVRD button (OSB 4).
2. From the FCR mode menu page display, depress the STBY button (OSB 1).

The OVRD button has the same function as the STBY button; depressing either button commands the FCR to STBY mode. At mode entry the mnemonic STBY appears in the upper left hand corner of the MFD and the OVRD mnemonic is highlighted. The OVRD button gives a quick way of selecting the STBY mode at any time, without having to select the FCR mode menu page first.

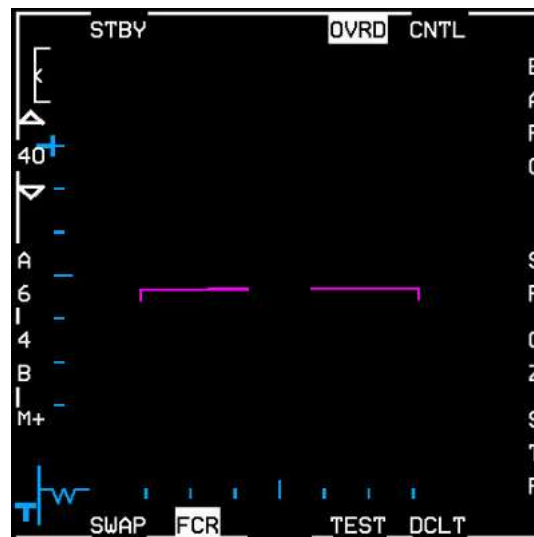

Figure 13 FCR OVRD

1.4.3.5 NO RAD / NOT SOI Display

Two displays are provided on the MFDs and HUD/HMCS to improve response to FCR operations.

The NO RAD display is provided on the HUD/HMCS to indicate that the FCR is not radiating. Situations that create this possibility are as follows:

- STBY/OVRD submode selected.
- RF switch in QUIET or SILENT.
- ACM:
 - Initial entry into ACM (without a bugged target from another air-to-air mode) 30x20 NO RAD.
 - From any ACM radiating submode, TMS down also enters ACM 30x20 NO RAD.
 - With HUD as SOI, TMS down commands ACM BORE NO RAD when the FCR is slaved to the HMCS.
 - With HUD as SOI, TMS up and held commands ACM BORE NO RAD when the FCR is slaved to the HMCS in BORE.
 - With FCR as SOI and ACM radiating, TMS down rejects the target and commands 30x20 NO RAD (if FCR is not slaved to the HMCS in BORE).



Figure 14 HUD NO RAD display

The NOT SOI display is provided on (FCR, TGP, and WPN) MFD displays to indicate that the format is not currently the Sensor of Interest. Since the SOI symbol has a tendency to blend with the video, this display reduces time spent searching for a possibly nonexistent SOI symbol.



Figure 15 FCR NOT SOI

1.4.3.6 FCR Informational Messages

FCR informational messages are displayed on the MFD when certain conditions within the FCR occur. These messages inform what corrective action, if any, should be initiated to make the FCR operational again.

1.4.3.6.1 “WAIT”

The “WAIT” message occurs when the FCR system is being reset. The length of time that the FCR needs to be reset is dependent on the condition which caused the message to appear. The FCR will start operation in 4 or 12 seconds without intervention. Once the commanded mode is entered, the message will clear.

1.4.3.6.2 “CHK FCR CONTROL PAGE”

The “CHK FCR CONTROL PAGE” message will be displayed after the FCR restarts and the BIT has completed. The purpose of this message is to inform the pilot that all pilot selectable parameters, i.e. control page values, azimuth selection, elevation bars and range scales are back to default values. The corrective action, if any, will be to reinitialize these to the desired values.



Figure 16 CHK FCR CONTROL PAGE message

1.4.4 Radar Air-to-Air Modes

The complement of air-to-air radar modes provides the capability for search, detection and track of multiple targets to provide situation awareness and to support air-to-air weapon delivery. The air-to-air modes are divided into two top level radar modes: Combined Radar Mode (CRM) and Air Combat Maneuvering (ACM) mode.

1.4.4.1 MFD Symbolology and Data

1.4.4.1.1 B-scope display

Air-to-air FCR modes use a synthetic display, called the B-scope (aka B-scan), produced by the radar signal processor. It takes the radar cone and stretches the bottom of the cone along the bottom axis of the display. The entire bottom of the scope represents your F-16's position, not just the centre. The target symbol as displayed on the radar represents your line of sight to the target.

This helps to separate contacts as they get closer, but is not as intuitive at first. To visualize the difference the figure below shows how the bottom of the pie-shaped radar coverage is stretched to fit the square B-scope display.

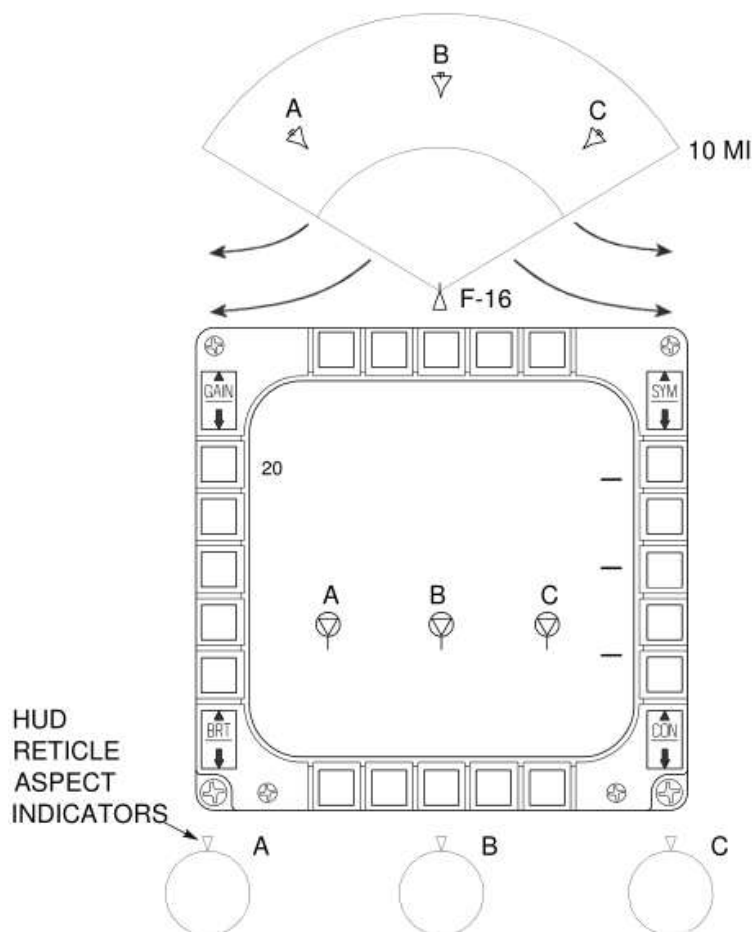

Figure 17 B-scope

1.4.4.1.2 Current FCR Operating Mode (OSB 1)

Possible mnemonics are:

- CRM: Combined Radar Mode
- ACM: Air Combat Mode

1.4.4.1.3 Current CRM/ACM Submode/Track Status (OSB 2)

Possible mnemonics are:

- CRM Submode:
 - RWS: Range-While-Search Mode
 - ULS: Up-Look Search Mode
 - VSR: Velocity Search w/ranging Mode
 - TWS: Track-While-Scan Mode
- ACM Submode:
 - 20: 30 x 20°
 - SLEW: Slewable
 - BORE: Boresight
 - 60: 10 x 60°

1.4.4.1.4 FCR A-A Field of View Select (OSB 3)

Options are:

- NORM: Normal FOV
- EXP: Expanded FOV

1.4.4.1.5 Standby Override Select/Deselect (OSB 4)

“OVRD” selects FCR standby page.

1.4.4.1.6 FCR Control Page Select (OSB 5)

The FCR Control Page is accessed via OSB 5 above the CNTL mnemonic. Depressing the OSB highlights the CNTL mnemonic and displays the control page options. The Control page may be accessed during flight without interrupting the present operating mode.

Currently only TGT HIS and AIFF CPL/DCPL is implemented in BMS.

1.4.4.1.6.1 Target History (TGT HIS) Rotary (OSB 18)

This rotary controls the display of target position history from the current frame and up to three previous frames.

- TGT HIS 1 displays targets detected on the current frame.
- TGT HIS 2 displays targets detected on the current and the preceding frame.
- TGT HIS 3 displays targets on the current and two previous frames.
- TGT HIS 4 displays all targets detected on the current and three previous frames.

Each history symbol becomes dimmer the longer it is displayed, disappearing entirely after it has been displayed the selected number of times. Initial value at power up in BMS is TGT HIS 2.

1.4.4.1.6.2 AIFF Couple/Decouple (OSB 10)

Advanced IFF (AIFF) CPL/DCPL is displayed adjacent to OSB 10. Selection couples the AIFF Interrogator FOV to the FCR FOV in the AIFF scan mode.



Figure 18 FCR CNTL page

1.4.4.1.7 Expanded Target Data (Below OSB 1-5 mnemonics)

1.4.4.1.7.1 Target Aspect Angle. Target aspect angle is displayed in tens of degrees (°) for the tracked target at the upper left corner of the MFD and is defined as the angle between the target longitudinal axis projected to the rear and the line of sight from the target to the aircraft. When the angle is at 0° the aircraft is on the tail of the target; at 180° the aircraft is on the nose of the target. Aspect angles from 0 - 70° indicate

a tail aspect, 70 - 110° indicate a beam aspect, and 110 - 180° indicate a front aspect. The L or R mnemonic displayed next to the aspect angle readout indicates the target wing closest to the aircraft.

- 1.4.4.1.7.2 Target Ground Track. Target magnetic ground track is displayed in 10° increments immediately to the right of the target aspect angle at the upper left of the MFD.
- 1.4.4.1.7.3 Non Cooperative Target Recognition (NCTR). If NCTR has been successful in identifying the bugged target the target ID (e.g. MG29) will be displayed under the FOV mnemonic, otherwise it will read UNKN (unknown).
- 1.4.4.1.7.4 Calibrated Airspeed for Bugged/Priority Target. Target calibrated airspeed (KCAS) is displayed in 10 knot increments below the OVRD mnemonic.
- 1.4.4.1.7.5 Target Closure Rate. Target closure rate is displayed in knots true airspeed (KTAS) at the upper right of the MFD. When in Coast the MFD displays “COAST”.

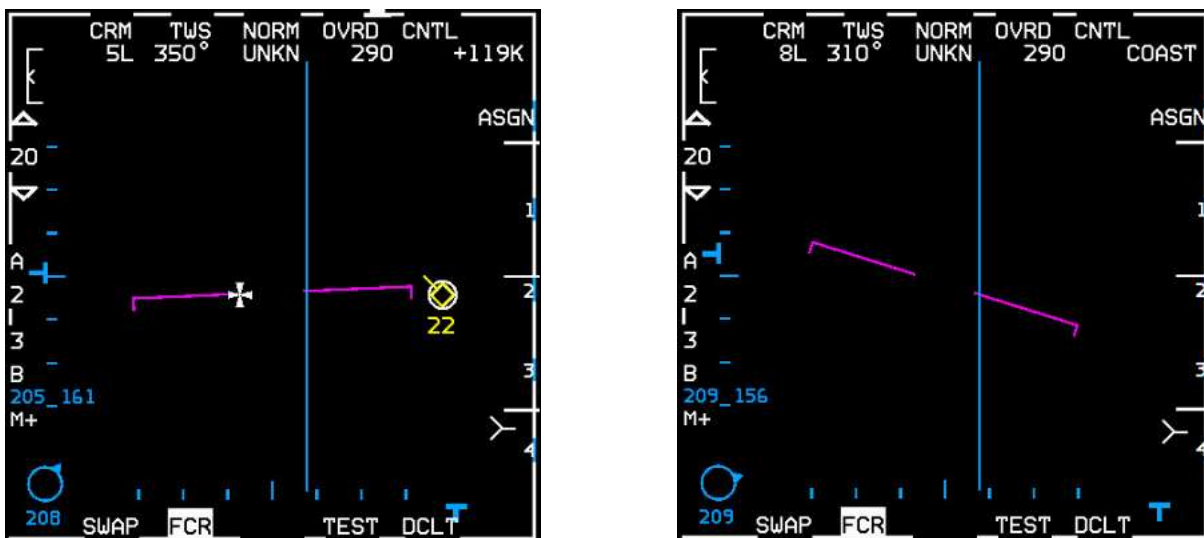

Figure 19 Expanded Target Data (left) and FCR in COAST (right)

1.4.4.1.8 Data Link Mode (OSB 6). IDM Data Link Mode rotary

IDM Data Link Mode rotary:

- ASGN
- CONT
- DMD

1.4.4.1.9 Data Link Assignment Transmit Status (OSB 7-10)

Depression of OSB 7-10 (representing flight member numbers 1-4) transmits an IDM Assignment to that flight member and causes “XMT” to be displayed for 2 seconds.

1.4.4.1.10 AIM-120 Dynamic Launch Zone (DLZ)

The dynamic launch zone consists of various range scales displayed along the right side of the MFD and HUD when the AIM-120 is the selected weapon.

1.4.4.1.10.1 Missile Time Remaining, Post Launch Range or Missile Time of Flight are displayed below the DLZ.

See also AIM-120 Advanced Medium Range A-A Missile (AMRAAM) and HUD Symbology: The Dynamic Launch Zone (DLZ).

1.4.4.1.11 FCR A-A Declutter Select/Deselect (OSB 11)

When the DCLT OSB is depressed selected items are removed from the MFDs. Declutter is deselected by depressing the DCLT OSB a second time.

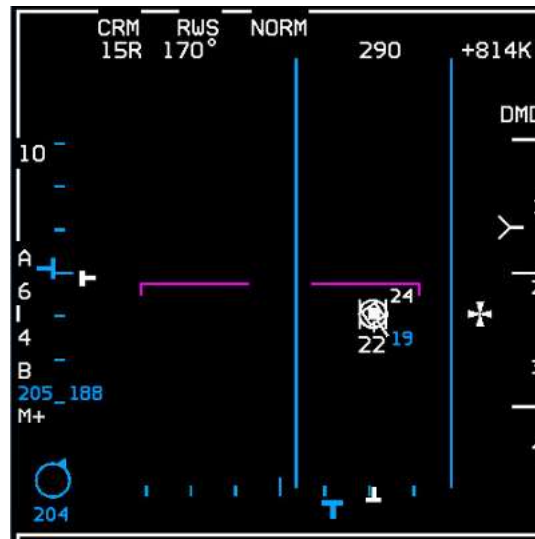

Figure 20 FCR DCLT

1.4.4.1.12 AIFF Interrogation Data (Adjacent to OSB 16)

The Interrogator Type mnemonic (M1/M2/M3/M4/M+/OFF) and the Interrogator Mode (SCAN/LOS) are displayed on the air-to-air FCR page. See IDENTIFICATION FRIEND or FOE (IFF) chapter in the T.O. BMS1F-16CM-1 (Dash 1) manual.

1.4.4.1.13 Bullseye Symbol/Bearing and Range (Adjacent to OSB 16)

The bullseye bearing and range are computed by the MMC and displayed at the lower left corner of the FCR and HSD pages adjacent to OSB 16. There are four possible bearing and range solutions (depicted above the bullseye circle) based on the mode of the radar page. The four bearing and range solution possibilities are:

1. From the mode-selected bullseye to the cursor. Bullseye is mode-selected and the cursor is present on the radar page.
2. From the mode-selected bullseye to the TOI (bugged target). Bullseye is mode-selected and the cursor is not present (the radar is in Single Target Track (STT) or suspended SAM).
3. From the currently selected steerpoint to the cursor. Bullseye is not mode-selected and the cursor is present on the radar page.
4. From the currently selected steerpoint to the TOI. Bullseye is not mode-selected and the cursor is not present (the radar is in STT or suspended SAM).

For solutions 3 and 4 the bullseye LOS Bearing and Range circle displayed at the lower left corner of the MFD is replaced with the Aircraft Reference symbol.

The bullseye LOS Bearing and Range circle displayed at the lower left corner of the MFD indicates the bearing and range from the current aircraft position to the bullseye (bearing solution A). The directional tic on the circle indicates the bearing to the bullseye while the 2-digit number inside the circle indicates the range (2-digit so max 99 NM).

The 3-digit number below the circle indicates the magnetic bearing from the bullseye to the current aircraft position (bearing solution B). Magnetic bearing and range from bullseye to ownship are also displayed on the HUD.



Figure 21 Merged Bullseye and Steerpoint Symbols

1.4.4.1.14 Radar Scan Coverage (OSB 17-18)

You control the power of the transmitter by setting the radar range and specify where the radar looks by controlling the position of the radar antenna.

The FCR can scan forward $\pm 60^\circ$ left and right as well as $\pm 60^\circ$ up and down, which means that the F-16 radar can scan a block of 120° by 120° . You control where the radar looks by first pointing your aircraft in the general direction of interest. Then you control the specific area by specifying the magnitude of the azimuth and elevation scan. You can also physically point the radar up or down, left or right within its gimbal limits of $\pm 60^\circ$.

While the radar antenna has this physical range of motion, it is important to understand that you will not be able to scan this entire volume at once. Think of each of the air-to-air radar modes as providing a certain amount of focus to the viewing area, like shining a torch in a dark room. As you narrow the beam of light from the torch and get more focus, you can acquire more information, but the area you can look at gets correspondingly smaller and anything you are looking at is more likely to notice you!

You control the azimuth by adjusting the scan volume. The azimuth scans, depending on the mode, can be $\pm 60^\circ$ (the whole width of the radar scope) centred about the nose, or $\pm 30^\circ$, $\pm 25^\circ$, $\pm 20^\circ$ or $\pm 10^\circ$ centred about the acquisition (ACQ) cursor anywhere within the $\pm 60^\circ$ gimbal limits.

The $\pm 25^\circ$ azimuth (3 bar) scan is exclusive to Track-While-Scan (TWS) and Dual Target (DT) SAM modes.

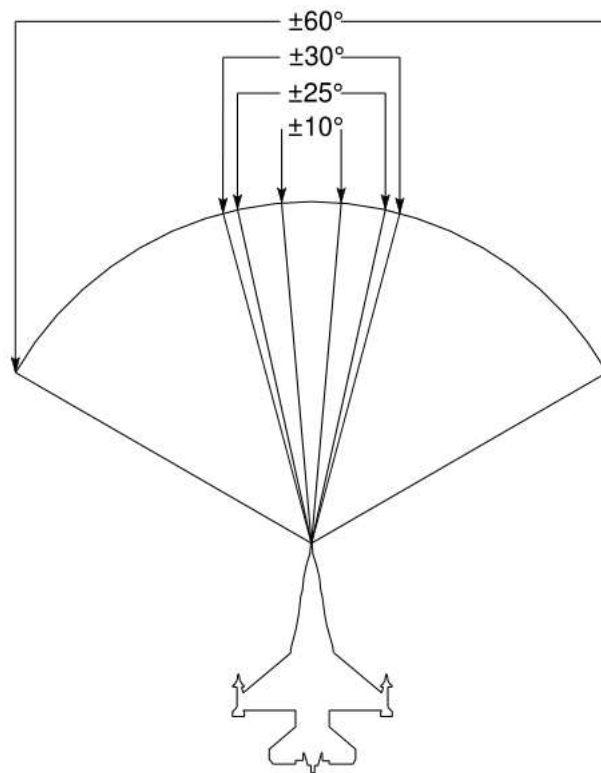

Figure 22 FCR Azimuth Limits

Radar elevation scan volume is controlled by specifying the bar scan. The beam that the antenna normally emits is not able to scan more than 4.9° in the vertical. If the radar just moves left to right and back that is considered 1 bar as it will scan just the single 4.9° slice of airspace. However, the radar can scan a larger area of vertical space if it moves down after a scan.

On a 2 bar scan, for example, the radar scans left to right, moves down a few degrees and scans back right to left. Because the radar antenna is pointing lower the return scan looks at a different area of space than the first scan.

Bar spacing is 2.2° for the 2 bar, 3 bar and 4 bar scans to overlap and avoid gaps in radar coverage.

A 4 bar scan covers the most area but takes the longest to complete. A 1 bar scan covers the least area but is the fastest; the 2 bar scan falls in between. You trade off coverage for increased refresh rate of targets.

3 bar ($\pm 25^\circ$ azimuth) scans are only available in Track-While-Scan (TWS) and Dual Target (DT) SAM modes.

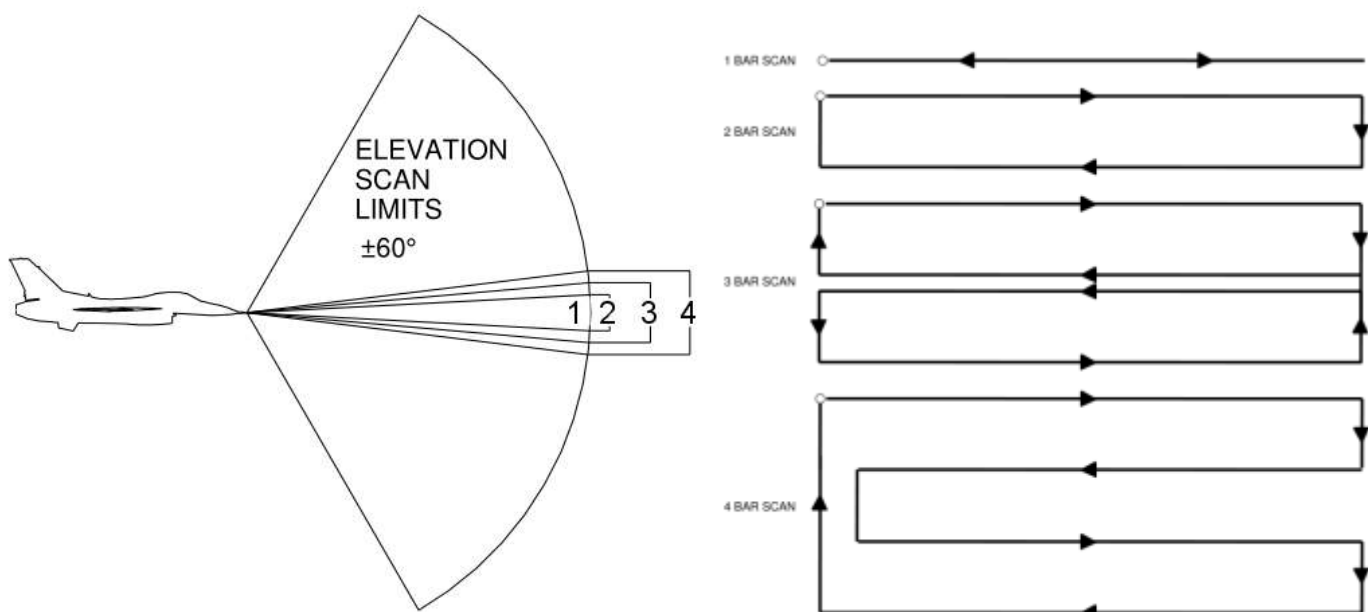

Figure 23 FCR Elevation Scan Limits (left) and Antenna Elevation Scan Coverage (right)

1.4.4.1.14.1 Radar Antenna Elevation

The scan pattern is adjusted for altitude coverage by the position of the ANT ELEV thumbwheel located on the throttle. The scan pattern tilt angle can be centred from $+60^\circ$ to -60° . The scan pattern is roll and pitch stabilized with the tilt angle referenced to the horizon.

1.4.4.1.14.2 Antenna Elevation Caret

Antenna elevation is indicated by the position of the horizontal T-shaped antenna elevation caret along the left edge of the MFD. The range is space referenced and runs from $+60^\circ$ at the top of the MFD to -60° at the bottom. On the left side of the display are 7 elevation tics, each representing 10° (-30° to $+30^\circ$).

The number of elevation bars that the radar scans is controlled via OSB 17, adjacent to the B mnemonic and one of the elevation bar mnemonics (1, 2, 3, or 4).

1.4.4.1.14.3 Minimum/Maximum (Min/Max) Search Altitudes

To aid in adjusting antenna elevation in TWS and RWS, Min/Max Search Altitudes (rounded to the nearest thousand feet) are displayed to the right of the ACQ cursor. Altitudes are at the ACQ cursor range and take into account antenna beam width, bar spacing and antenna elevation.

1.4.4.1.14.4 Antenna Azimuth

Antenna azimuth is indicated by the position of the T-shaped antenna azimuth marker along the bottom of the MFD, where the left edge of the FCR video represents -60° , the centre of the video represents 0° and the right edge represents $+60^\circ$. The antenna azimuth marker is space referenced in RWS. When not in $\pm 60^\circ$ two vertical scan lines are displayed in search, spotlight, and SAM to indicate minimum and maximum azimuth scan limits. The vertical azimuth scan limit lines are also available in TWS but are not available in TWS Expand or in STT. The lines are blanked as they approach the edge of the MFD.

Scan width may be changed by moving the ACQ cursor to the left or right edge of the MFD, causing the scan width to toggle between $\pm 30^\circ$ and $\pm 60^\circ$. If the present scan width is $\pm 10^\circ$ (commanded via OSB) then ACQ cursor deflection toggles the scan width to $\pm 30^\circ$. Subsequent ACQ cursor control inputs toggle the scan width between $\pm 30^\circ$ and $\pm 60^\circ$.

The ± 60 degree azimuth scan width is the initial selection on the FCR format. Depressing OSB 18, adjacent to the A mnemonic selects one of the following scan width mnemonics in the rotary from wide to narrow:

- 6 - $\pm 60^\circ$ scan width, centred about the nose (not available in TWS).
- 3 - $\pm 30^\circ$ scan width, centred about the ACQ cursor (not available in TWS).
- 2 - $\pm 25^\circ$ scan width, centred about the ACQ cursor (TWS & DT SAM only).
- 1 - $\pm 10^\circ$ scan width, centred about the ACQ cursor.

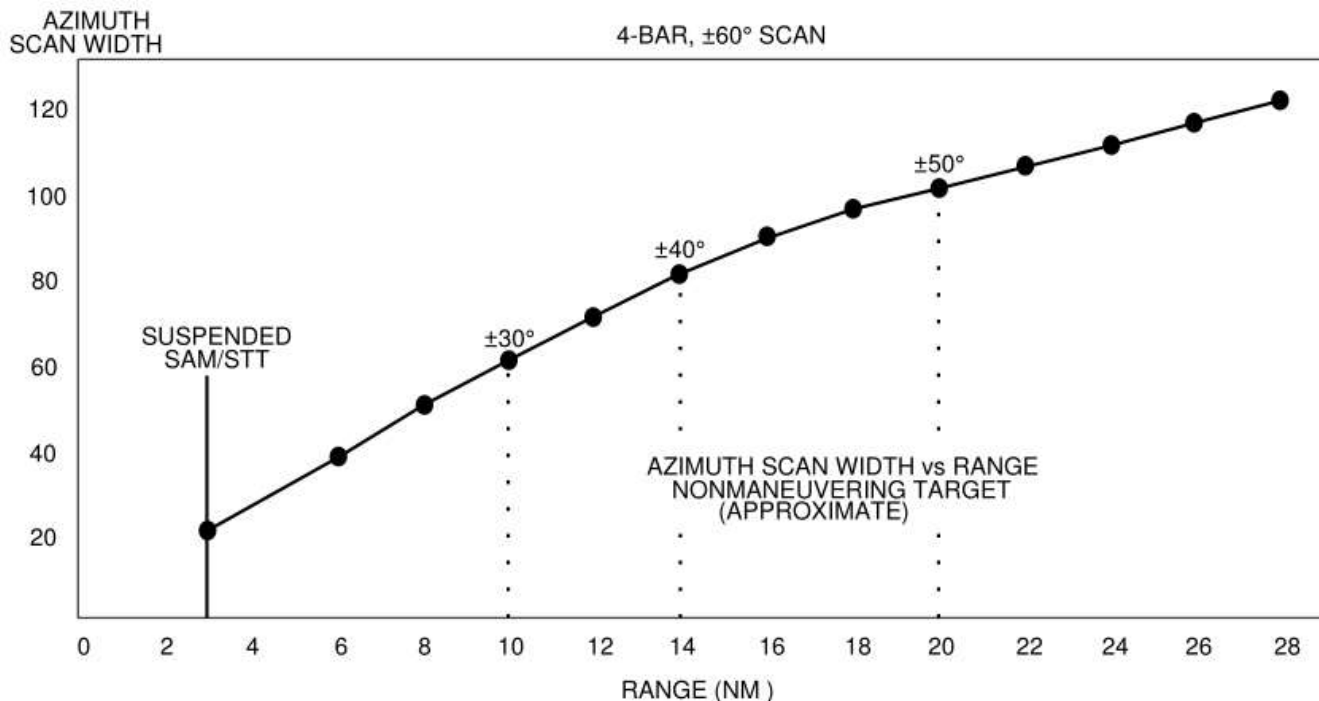

Figure 24 SAM Azimuth Scan Width vs Range

In all A-A search modes except TWS, search volume control allows the ACQ cursor to be placed anywhere within the FCR scan volume. Azimuth gates no longer move with the ACQ cursor unless you get close to them and bump them. When the centre of the ACQ cursor is within 4° of the edge of the search volume, the search volume centre will move with ACQ cursor motion.

In SAM, the pilot has control of the maximum size and location of the antenna scan pattern as in RWS. Typically, the radar displays azimuth scan limits on the MFD indicating the actual scan volume. The azimuth scan limits on the MFD may be less than the pilot scan width because there are occasions when the scan volume is reduced in order to allow SAM to maintain quality tracks on the SAM targets; see Figure 24 above for scan width vs. range in SAM.

In DT SAM, the radar supports the pilot selected scan pattern until one of the targets has a range of less than 10 NM or an AMRAAM has been launched. In either case, the radar will enter the SAM Dual Target Track (DTT) submode, where it sequentially updates each of the SAM targets (ping pong) and does not interleave search processing.

1.4.4.1.15 FCR Range Display (OSB 19-20)

Target range can be determined by observing the target symbol position along the MFD range scale. Each of the three tic marks positioned along the right edge of the display divided the range into 4 equal sections. Range scale options are available as an increment/decrement function adjacent to the range Δ ∇ OSBs. The range scale is selected from a rotary containing: 5, 10, 20, 40, 80 and 160 NM ranges. Depressing either of these OSBs will step through the rotary.

1.4.4.1.15.1 The range scale can also be changed hands-on while in search via the cursor controller function of the CURSOR/ENABLE control. If the ACQ cursor is slewed to a position of either less than 5% or greater than 95% of the selected range scale, the next lower or higher scale will be selected and the ACQ cursor will be positioned to approximately 50% in range of the selected scale and at the same azimuth as the previous scale. Range scale switching will not occur if it causes the target track to move off the display.

1.4.4.1.16 Target Symbolology

Search targets are displayed as solid squares with an aspect “Head” or “Tail” indicator. A bugged target is represented on the MFD as a circle around a solid square with a velocity vector. The tracked target may later be represented by a different symbol following identification of the bugged target. The bugged target is represented on the MFD by placement of a circle around that target symbol. In STT all other search targets are removed from the display and only the bugged target is displayed. See Figure 40 Air-to-Air FCR Symbolology below.

1.4.4.1.16.1 The bugged target is the highest priority target in all track modes (TWS, SAM, DTT). The bugged target altitude is displayed numerically in thousands of feet MSL, just below the bugged target. Target aspect angle, magnetic ground track, calibrated airspeed (KCAS) and closure rate (KTAS) are displayed across the top of the MFD. Only one bugged target may exist.

1.4.4.1.16.2 The tracked target symbol provides additional data. The symbol rotates in 11.25° increments defined by the aspect angle (see Figure 25). A line extending from the nose of the symbol increases in length as absolute target velocity increases. Target altitude is displayed in thousands of feet beneath the symbol.

The target symbol as displayed on the radar represents your line of sight to the target. In the example top left you can see that any contacts moving directly down the B-scope display are always coming straight towards you.

In the example top right, when you look at Target A (which is further away), you see more of the target’s front quarter (which is why the aspect angle is closer to 0°).

Even though Target C is pointed in the same direction as Target A its orientation on the radar display (and its aspect angle) are closer to the 9 o’clock position because it is closer, so you see more of its right side.

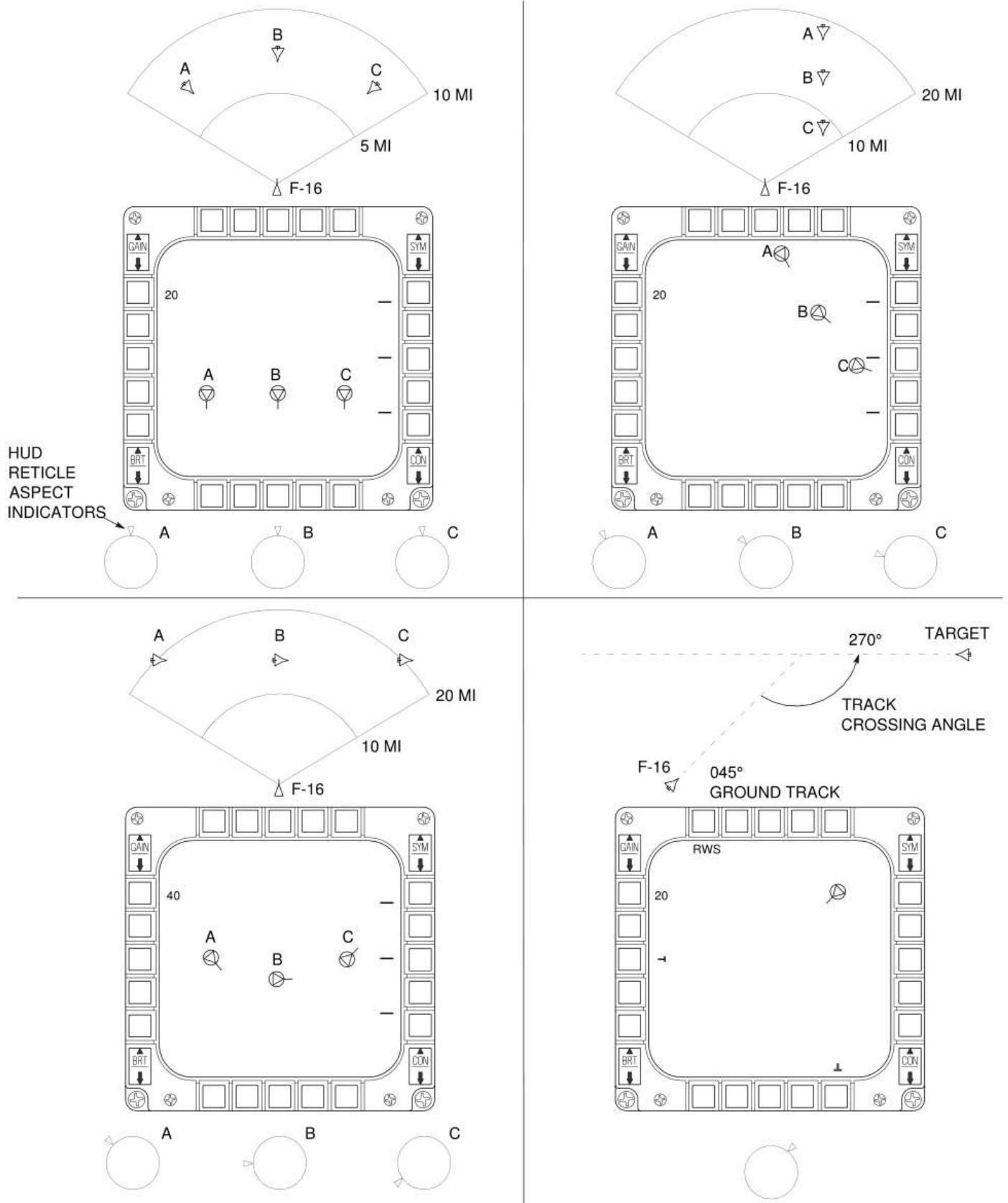

Figure 25 Tracked Target Symbology

1.4.4.1.17 Acquisition (ACQ) Cursor

The cursor symbol “| |” displayed during search consists of two parallel vertical lines. Search targets are locked on by slewing the cursor over the search target symbol via the CURSOR/ENABLE control and designating via a TMS up. The maximum search altitude readout is displayed digitally in thousands of feet at the upper right of the ACQ cursor; the minimum search altitude readout is displayed at the lower right.

The width of the ACQ cursor = FCR range / 10, e.g.: on a 40 NM range scope the ACQ cursor width will be 4 NM.

1.4.4.1.18 Steerpoint Symbology

The pyramid-shaped (wedding cake) steerpoint symbol is displayed at the computed ground range and relative bearing from the aircraft to the selected steerpoint.

1.4.4.1.19 Horizon Line

The horizon line indicates the aircraft roll and pitch angles.

Aircraft roll angle is read by comparing the angle the horizon line makes with the normal level position (parallel with the top/bottom edges of the MFD) zero.

Aircraft pitch angle is read by observing how far the horizon has advanced from the centre of the display. The edges of the display represent $\pm 60^\circ$ pitch.

The horizon line is limited at the edge of the display for angles greater than $\pm 60^\circ$. Each end of the horizon line represents 30° left and right of aircraft flight path.

1.4.4.1.20 Collision Antenna Train Angle (CATA)

The CATA steering symbol “✕” provides horizontal steering to the tracked target and is displayed at target range. The CATA symbol is not displayed when the collision angle exceeds 60° . To intercept the target the aircraft should be maneuvered toward the CATA to place the CATA at the centre of the FCR display.

1.4.4.1.20.1 The CATA symbol is not displayed in newer blocks when the AIM-120 AMRAAM missile is selected; the ASC is used for steering until the range is $1.2 \times R_{AERO}$.



Figure 26 CATA

1.4.4.2 Air-to-Air Features

1.4.4.2.1 Enhanced Search Display (ESD)

ESD automatically includes a “Head” or “Tail” indicator on all search targets. The ESD provides a target aspect indication for all search targets with Doppler. The aspect indication provides the pilot with increased target information by displaying a short line attached to the search target symbol showing whether a target is head or tail aspect. When a target is head/high aspect (including near beam targets at 100° right/left) the indication will be pointing down. When a target is tail/low aspect (including near beam targets at 80° right/left) the indication will be pointing up from the search target. This is available in RWS, VSR, TWS, SAM, and DT SAM display modes.

1.4.4.2.2 Search Altitude Display (SAD)

The SAD capability is a feature which provides an estimate of a search target’s altitude. The SAD feature is displayed in RWS, SAM, DT SAM and TWS when the ACQ cursor is slewed over a search target symbol.

The SAD value is displayed as thousands of feet above Mean Sea Level (MSL), rounded off to the nearest thousand feet. If the FCR is in a single bar search scan, the altitude reported by SAD will be approximately the altitude corresponding to the centre of the beam. The SAD is removed when the ACQ cursor is moved away from the search target.

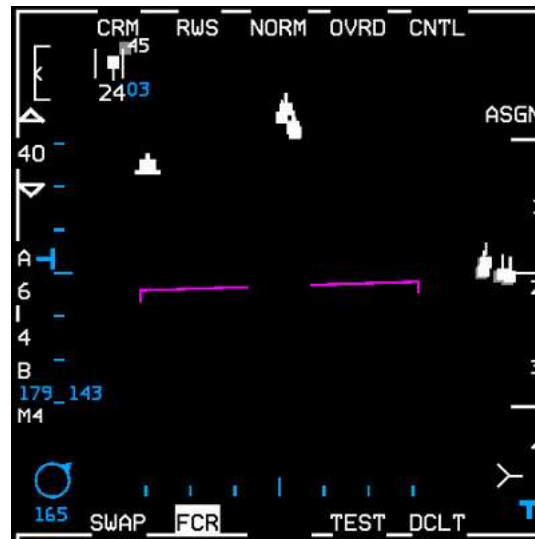

Figure 27 ESD & SAD

1.4.4.2.2.1 Cursor area of effect

The cursor area of effect is actually slightly larger (105%) than the size of the ACQ cursor (aka captain's “| |” bars) displayed on the screen. This means you will get SAD display as the cursor moves very close to but not quite over a radar target on the display. This greatly improves sorting capability without having to expand the field of view to separate the contacts.

For example to sort (i.e. designate/bug) the trail aircraft in a lead-trail group high-aspect on you simply move the cursor up to the upper side of the group and TMS Up. The larger cursor area will allow you designate the trailing contact without having to put the cursor precisely over the exact contact you want.

1.4.4.2.3 Spotlight Search

Spotlight search provides hands on temporary switching to a 4 bar $\pm 10^\circ$ scan pattern, increasing opportunity for target detection in RWS and TWS.

Depressing and holding TMS Up for longer than 1 second will command the radar to spotlight search. The scan is centred about the acquisition (ACQ) cursor and elevation (ANT ELEV) wheel setting and can be slewed. When slewing the ACQ cursor, the spotlight scan pattern will remain centred in azimuth on the ACQ cursor. The scan coverage reverts to the previous pattern when TMS is released, unless a target is beneath the ACQ cursor, at which time the radar will attempt to acquire and track the target. Spotlight search is not available in RWS EXP.

Spotlight scan in TWS is similar to spotlight scan in RWS. The TWS spotlight search volume is initially centred about the ACQ cursor. The spotlight search volume is not biased by the TWS track files, but is controlled through the use of the ACQ cursor and the ANT ELEV thumbwheel. In other words, the pilot can override the TWS bug priority in azimuth and elevation. Spotighting outside the TWS priority scan volume will help establish track files on groups outside the previous TWS scan volume. Track updates on the target of interest (TOI) and targets with AIM-120 missiles in flight will only occur if the spotlight scan volume includes these targets.

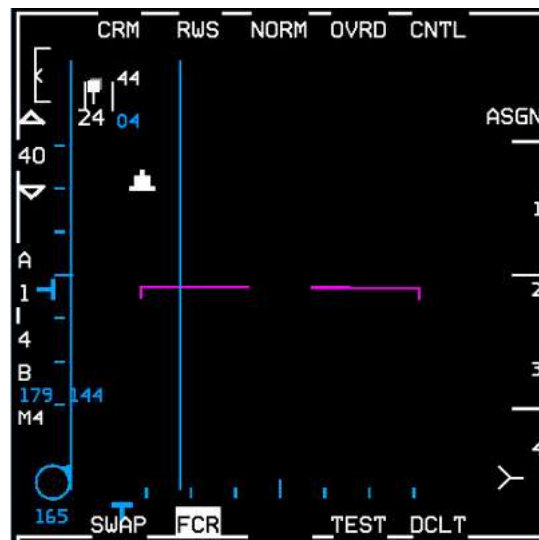

Figure 28 Spotlight Search

1.4.4.2.4 Expanded (EXP) Display

An EXP A-A display is available to more clearly resolve closely grouped targets in RWS, SAM and TWS. A 4 to 1 expansion in range and azimuth about the ACQ cursor is commanded by using either the EXPAND/FOV button (aka Pinky switch) on the stick, or by pressing the Field of View (FOV) OSB 3 on the MFD. The same switch actions toggle back to the normal (NORM) display.

The MFD displays a NORM or a flashing EXP mnemonic to indicate the current FOV. The ACQ cursor remains at its true range and azimuth in reference to the unexpanded display, while all other targets are expanded 4 to 1 about the ACQ cursor.

Coverage, location, and size of the antenna scan pattern remain unchanged in EXP; only the location of the targets on the display changes. Bump AZ and Auto Range scale changes due to target range are disabled during EXP.

The radar will automatically exit EXP when STT is commanded.

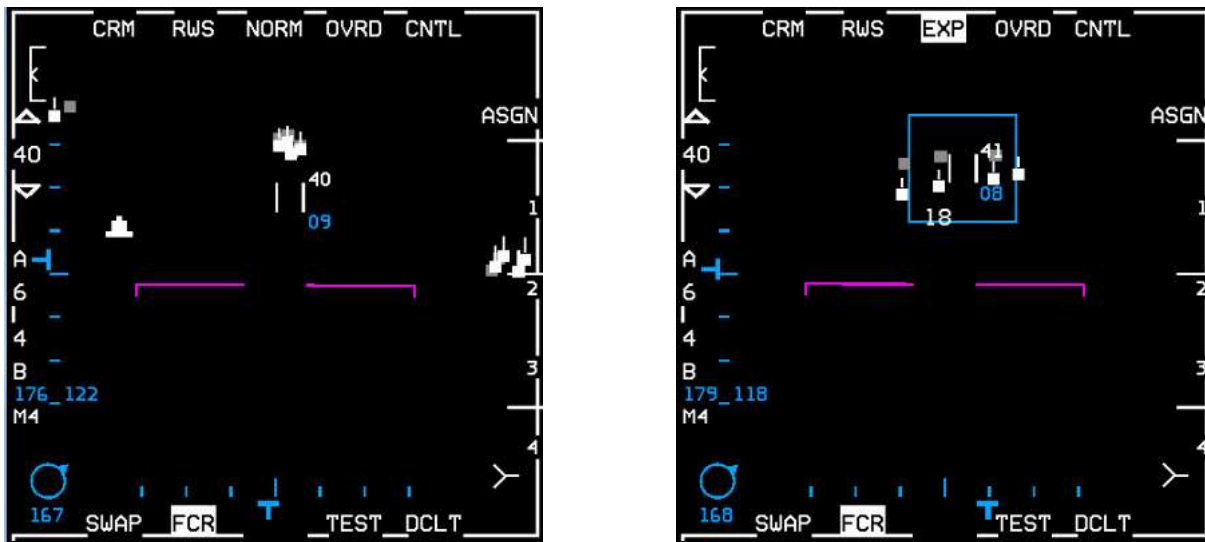

Figure 29 RWS NORM and EXP Display

1.4.4.2.5 Non-Cooperative Target Recognition (NCTR)

In STT mode the radar will use Non Cooperative Target Recognition (NCTR) algorithms to attempt to identify the aircraft being tracked. NCTR analyses returns from the radar and compares them to stored profiles.

NCTR in the F-16 relies on the turbine blade return from each aircraft and hence will only work if the target aircraft is head-on and the turbine blades are visible to the radar. If the radar cannot 'see' the turbines clearly and is unable to identify the target "UNKN" will be displayed. "WAIT" means that radar is analysing data.



Figure 30 NCTR

1.4.4.3 **Combined Radar Mode (CRM)**

The CRM is designed to simplify pilot switchology by providing hands-on accessibility of Range While Search (RWS), Up-Look Search (ULS), Velocity Search with Ranging (VSR) and Track While Scan (TWS) modes. CRM is divided into two modes of operation - a search mode and a multiple target track mode. The search modes available are RWS, ULS, and VSR. The multiple target track mode is TWS. RWS, ULS, VSR, and TWS are referred to as CRM submodes.

Both the Situation Awareness Mode (SAM) and Single Target Track (STT) are supported by CRM. STT is available in all A-A modes while SAM is available in RWS and ULS. SAM can support up to two track files while maintaining situation awareness.

1.4.4.3.1 Mode Entry

The submode that the radar enters when the pilot selects CRM is dependent upon whether the radar has been in CRM previously. If CRM is being selected for the first time since power up, the radar will enter RWS. However, if the radar has previously been in CRM, the radar will enter the CRM search submode last exited (RWS, ULS, or VSR). Therefore the CRM submode selection is not master mode dependent.

Upon CRM entry from ACM STT, SAM will be entered if the radar was in RWS or ULS the last time CRM was left and VSR STT will be entered if the radar was in VSR last.

1.4.4.3.2 Submode Selection

Once the radar has entered CRM, the pilot has the capability of entering TWS from any CRM search submode by pressing the Target Management Switch (TMS) right for more than 1 second. The pilot can return to the CRM search submode by depressing OSB 1 on the MFD and then reselecting "CRM" from the menu. If there was a bugged target in TWS this target will become the SAM target if the CRM search mode is RWS or ULS, or the STT target if VSR was selected.

There are three hands-on methods to return to the CRM search submode:

- To transfer without maintaining track on a TWS bugged target, a TMS down (Return-to-Search) followed by a TMS right and hold, **or** TMS down 3 times, will clear all track files and transfer back to the CRM search mode last exited.
- To maintain track on the TWS bugged target the pilot can make a quick, momentary transfer to Dogfight (DGFT) and back (Air Combat Maneuvering (ACM) must be the DGFT programmed mode).
- And lastly, the pilot can command the last CRM search submode by holding TMS right for more than 1 second. Upon return, the previously selected search mode will be selected and the TWS bugged target will become a SAM or STT target.

CRM has a search mode rotary: RWS → ULS → VSR. The CRM search mode is changed by depressing OSB 2 which causes the next search mode in the rotary to be selected.

1.4.4.3.3 Target Acquisition and Management

Figure 31 A-A HOTAS TMS functions (FCR SOI)

The following paragraphs provide an overview of CRM operations using the Target Management Switch (TMS):

- Designating (TMS up) on an RWS search target changes it to a bugged/priority target and places the FCR into the SAM submode.
- Holding TMS up will initiate spotlight search. Upon release of the TMS, acquisition/track is attempted if a search target is bracketed by, or very close to, the ACQ cursor.
- Designating on a *second* RWS search target while tracking a target in SAM will transition the radar to dual target (DT) SAM submode. When DT SAM is entered, the first bugged target remains the primary target, the second designated target becomes the secondary target and the scan volume is adjusted to allow each target to be updated as the radar continues to search in RWS.
- When both the bugged/primary target and the secondary target are beyond 10 NM the search volume is fixed at $\pm 25^\circ$ azimuth, 3 bar. The scan pattern is centred in azimuth on the ACQ cursor and is controlled in elevation via the ANT ELEV wheel. TMS right for less than 1 second will step the bug between the two targets. When either target is within 10 NM search is suspended and the radar spends all its time tracking the bugged and secondary targets (aka ping pong).

- When the scan pattern is moved off of both targets in DT SAM the scan width will adjust to optimize track versus search time. As the scan pattern is moved away from both targets the scan width will become narrower. When the bugged target is within 3 NM the radar automatically drops track on the secondary target and switches to STT on the bugged target.
- Designating on a bugged SAM target also places the radar into STT.
- Designate actions (TMS up) change submodes from RWS → SAM → DT SAM → STT. Return-to-Search (RTS) actions (TMS down) change the submodes back the other way. For example, if the pilot designates a target and puts the radar into SAM submode a subsequent TMS down will return the bugged target to a search target and the radar will return to RWS. TMS down in STT will switch the radar to DT SAM if a secondary target is being extrapolated, or to SAM if there is no secondary target. TMS down from DT SAM will switch the radar to SAM. TMS down from SAM will return the radar to RWS.
- Depressing TMS right for more than 1 second, from any CRM RWS mode with or without a tracked target (SAM, DT SAM, or STT), transitions the radar to TWS and retains any pre-existing bugged targets.
- Commanding TMS right and hold from TWS with a bugged target and system track files will transition the radar to DT SAM. The bugged target in TWS will become the primary (bugged) target in DT SAM. The TWS system track file selected as the DT SAM secondary target is based on MMC and FCR prioritization, e.g. ACQ cursor over target or system track file.

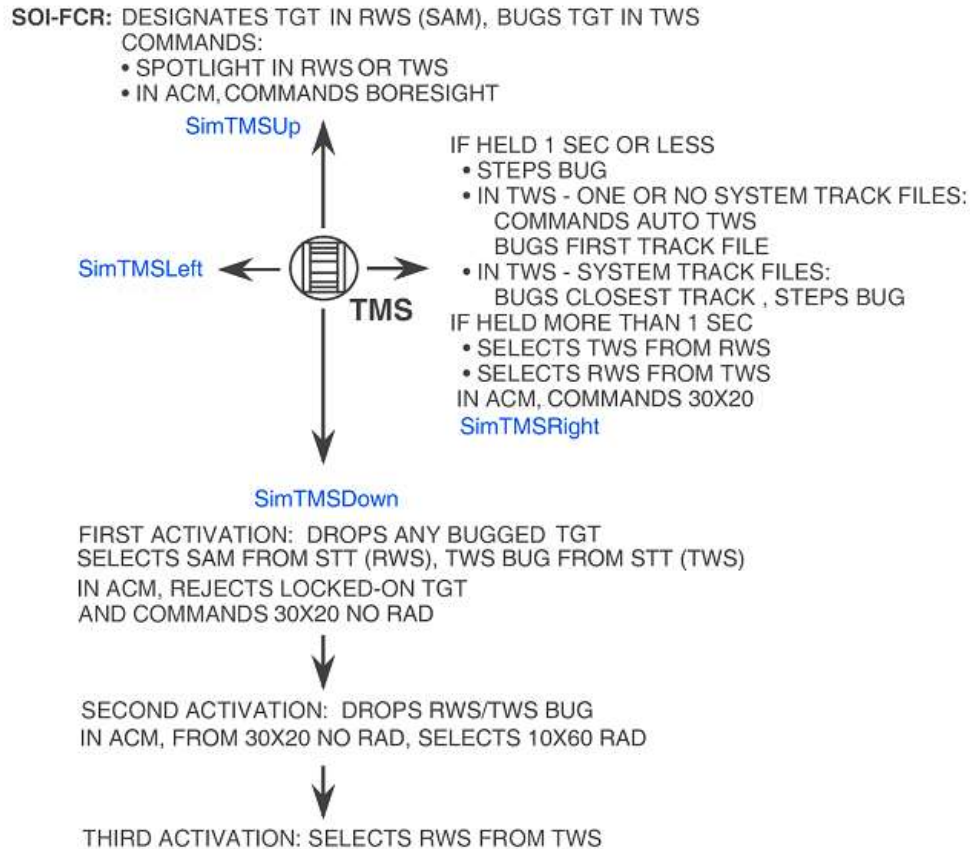
1.4.4.4 *Range-While-Search (RWS) Mode*

In the Range-While-Search (RWS) mode the radar searches a selectable volume of space and displays the position of any detected targets on the MFD. No track data (target range, velocity, angle or ground track) is available on these detected targets. See Figure 29 for RWS display in NORM and EXP FOW.

A specific target can be tracked/bugged by slewing the acquisition (ACQ) cursor over the target and depressing and releasing TMS up (designate). This causes entry into Situation Awareness Mode (SAM). TMS right for less than 1 second steps the bug to the next priority target in DT SAM.

Holding TMS right for more than 1 second changes the mode to TWS. Stepping the radar target of interest (TOI), or bugged/priority target, is limited to targets that are displayed on the currently selected FCR range scale.

In RWS, the ACQ cursor is used to:

- Request the Search Altitude Display (SAD).
- Select a target for SAM or STT.
- Change the search pattern azimuth width.
- Change the display range scale.
- Position the EXP square when EXP is entered.

1.4.4.5 *Up-Look Search (ULS)*

The ULS mode is a search submode of the CRM and in the real APG-68 is designed to detect aircraft at high altitudes in look-up, clutter-free situations. Clutter is not rejected in ULS. When the scan coverage illuminates the ground or certain cloud formations, many false targets are displayed. ULS is able to detect targets at longer ranges than RWS since its processing is designed for use in a clutter-free environment. As these differences are not currently modelled in BMS ULS is functionally identical to RWS in BMS.

In the real APG-68 ULS is identical to RWS in the areas of target display, cursor control and scan coverage but Enhanced Search Display is not presented in ULS since Doppler information is not available in ULS.

Manual acquisition to SAM or STT from ULS is identical to acquisition from RWS.

1.4.4.6 *Velocity Search with Ranging (VSR)*

VSR is a search submode of the CRM that interleaves high and medium Pulse Repetition Frequency (PRF) waveforms to provide long range detection of forward aspect targets. VSR is designed to detect forward aspect targets only. In order to be displayed in VSR, targets must have a velocity component along the radar's LOS directed toward the F-16. Hence this mode will only display contacts that are closing; contacts that are moving away (extending) are not displayed.

Contact detection and display in VSR is a two-step process consisting of a high PRF scan followed by a medium PRF scan. The first scan is called the Alert scan during which a contact is first detected and its azimuth and velocity are stored. Immediately after a Confirm scan is initiated with which the range is determined. After the contact has been detected in both Alert and Confirm scans, the target is displayed.

Targets are displayed on the MFD as solid squares in a B-scope presentation similar to RWS. Only contacts that are closing are displayed.

Manual Acquisition is the method by which the pilot selects a target to track in STT. Acquisition from VSR is the same as from RWS, except that a single Designate (TMS up) switches to STT. SAM cannot be entered directly from VSR.

The cursor is used to select a target for STT, initiate SAD (Search Altitude Display), move the antenna search pattern in azimuth, change the search pattern azimuth selection and change the displayed range scale.

Although only closing targets are detected and displayed in VSR search, acquisition of other targets is not specifically inhibited. This allows the pilot to acquire a turning target that was forward aspect or closing in VSR search, but has turned to a tail aspect or extending target by the time acquisition is commanded, or acquire a tail aspect target that just by coincidence happens to be in the same angular line of sight as an alert for a forward aspect target.

Since the VSR mode is specifically tailored for detection of long range closing targets, it is the optimum mode for a corridor search mission. Although it can be operated with larger scan volumes, frame times lengthen and reduce the effectiveness of the mode, so VSR is best utilized with a small search pattern (1 or 2 elevation bars by $\pm 10^\circ$ or $\pm 30^\circ$ in azimuth).

1.4.4.7 Track While Scan (TWS)

TWS is the multiple target track submode of the CRM and is designed to automatically track multiple airborne targets. Track information is formulated from repetitive search target detections as the antenna sweeps the scan volume.

Options are available for target display, target prioritization, selecting search volumes, and target rejection. While TWS tracks multiple targets, the pilot may select a target for STT to improve the accuracy of the track data for that target.

1.4.4.7.1 Scan Patterns

To switch to the TWS submode, the pilot may press OSB 2 until "TWS" is displayed, or hold TMS right for more than 1 second to switch from RWS/ULS to TWS. Upon entering TWS the radar azimuth will initialize to an "A2" or 50° azimuth scan ($\pm 25^\circ$ either side of boresight) and the elevation will initialize to a 3 bar "3B" scan.

Three scan patterns are available in TWS. They are:

$\pm 60^\circ$, 2 bar

$\pm 25^\circ$, 3 bar

$\pm 10^\circ$, 4 bar

1.4.4.7.2 TWS Mechanization

As its name implies, TWS tracks multiple targets while searching for others. It is mechanized to begin forming track files automatically from RWS search targets (solid squares) when the radar receives two hits (the radar detects something twice) in 6.5 seconds.

The radar is able to track 10 targets simultaneously. Since the radar does not pause on the track files while scanning, the track's positions are extrapolated in between updates (when the radar detects them again).

If a target is not updated, i.e. detected in 13 seconds, the radar will dump the track file until the target is detected again, whereupon it will rebuild it into a track file. A dump could happen for a number of reasons, including a target moving out of the radar's current azimuth scan, elevation scan, or both. In Figure 32 below right the track files at 21,000ft are outside the scan coverage, being extrapolated and about to be dumped.

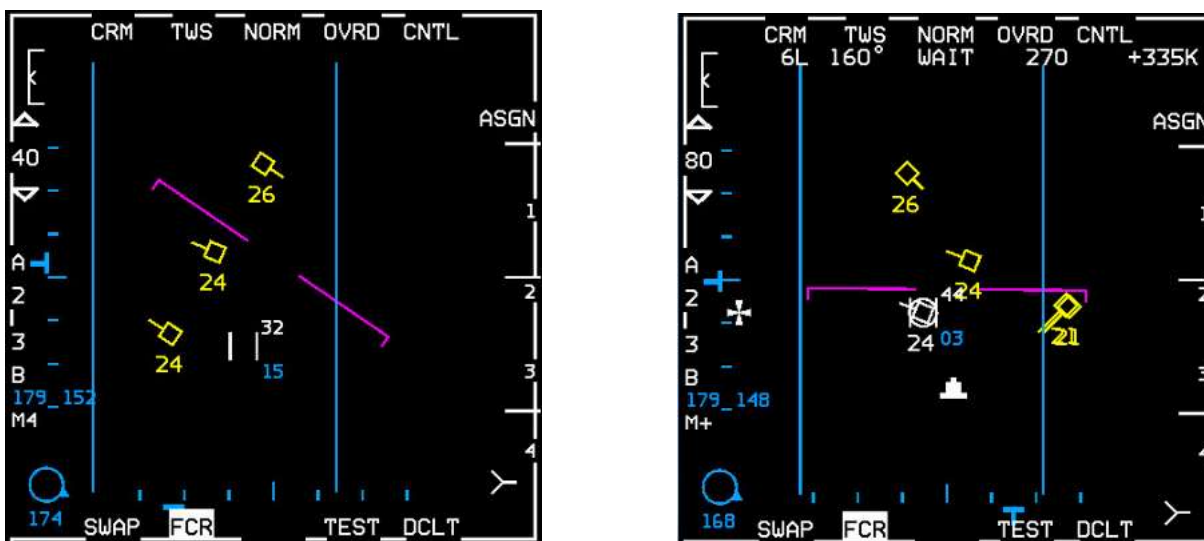

Figure 32 TWS (left) and TWS with bugged/priority target (right)

Also for example, if the pilot is tracking 10 targets and decides to designate on a search target, the radar will dump the lowest priority track and automatically upgrade the search target into a track file. If the radar has not received a hit on a track on its return scan where the radar thinks it should be based on the target's last heading and speed, the track file will turn from yellow to red to indicate this. When the track is detected again, it will turn back to yellow.

If a track is no longer detected it will turn red like previously mentioned and extrapolate for 13 seconds total. The last 5 seconds before the radar dumps the track, the track will begin to flash. Tracks are prioritized by range and the order in which they were built.

Without a bugged target, the azimuth scan centres on the cursors and elevation is controlled manually. When a target is bugged the azimuth is biased to keep the bugged target in the scan and the elevation is centred on the bugged target. If the antenna elevation is tilted while the pilot has a bugged target, upon dropping the bug, the elevation scan will move according to what the pilot commanded to reflect the position set by the antenna elevation controls.

1.4.4.7.3 Target Management (Moving the "Bug")

There are two ways to bug targets. The pilot may either slew the cursors over to a track file (or search target) and designate, or may TMS right to jump to the closest track file. TMS right again will step the bug to the next highest priority track file and so on.

The pilot may enter STT (Single Target Track) by slewing the cursors over the bug and pressing TMS up. This will erase all search targets and tracks from the radar, although the tracks will extrapolate for 13 seconds. TMS down (aka RTS (Return-to-Search)) is used to return to TWS, the extrapolated tracks will reappear and the target will be bugged. If RTS is commanded again, the pilot will drop the bug and the radar will continue to TWS. If RTS is commanded a third time, the radar will dump all tracks and begin rebuilding tracks automatically. If RTS is commanded a fourth time, the radar will go back to RWS.

Targets are detected in TWS as they are in RWS, and search detection symbols (small filled squares with head or tails) are displayed at the target range and azimuth. Search targets may be either manually or automatically acquired and tracked. Search detections whose ground speed along the radar line of sight is greater than 200 knots will be automatically acquired and tracked by the radar as described above. Targets whose speed is slower than 200 knots can be acquired manually by placing the ACQ cursor over the target and designating. The speed gate prevents using a track slot for a low threat target or a potential false alarm.

1.4.4.7.4 TWS Operational Considerations

TWS provides a multiple target track situation awareness capability by limiting the time spent on updating track files. In contrast, STT spends considerably more time updating the bugged target at the expense of situation awareness (SAM provides track quality between TWS and STT quality).

Since TWS limits the amount of time that is spent updating a target a maneuvering target can be a significant distance away from its expected position at the time of the next track update. The error introduced during the interval between track updates can result in "jumpy" TWS track symbology on the MFD and HUD as compared to SAM and STT, or even track files disappearing and reappearing.

Aside from some jumps of the TWS track symbology, the time between updates makes TWS an undesirable mode for target ranges of less than 5 NM when the target is maneuvering. If a target engagement is expected, the pilot should consider entering STT or SAM.

1.4.4.8 Single Target Track (STT)

STT is a submode of all radar modes. It is designed to automatically maintain a highly accurate track of a single airborne target for weapon delivery.

1.4.4.8.1 STT Display

A STT bugged target is displayed just like all other bugged targets. Target altitude and target data are presented just like TWS and SAM bugged targets.

When the target is acquired in RWS, ULS and VSR, the target symbol changes from a small square (search target symbol) to an open square enclosed in a circle (tracked target symbol). When the target is acquired in TWS, the target symbol remains the same and all other targets displayed (if any) are blanked from the MFD display and extrapolated by the radar software for a maximum of 13 seconds from the last time each target was updated. In ACM, the target acquired will appear as an open square enclosed in a circle. In the missile modes, this symbol will also have a tail if a slaved AIM-120 missile has been launched at the target. The target range can be determined by comparing the position of the symbol to the range marks on the right edge of the display or using the HUD/HMCS range window. The lateral position of the symbol represents azimuth.

Several features are available to aid in visually locating, intercepting and evaluating the target including:

- A target designator box or locator line is displayed on the HUD/HMCS.
- An intercept steering symbol is displayed on the radar format.
- Target data is displayed digitally on the radar format and, to a lesser extent, on the HUD/HMCS.
- The radar range scale is switched automatically to keep the target symbol in the central area of the MFD.

During STT a cross “✕” is displayed on the radar format at target range to aid in performing various intercept maneuvers. By comparing the position of the symbol versus the centreline of the MFD, the pilot can fly collision, pursuit, or lead steering. This intercept steering symbol provides horizontal steering only, not vertical. If the collision angle exceeds $\pm 60^\circ$, the intercept steering symbol disappears off the edge of the MFD.



Figure 33 STT

1.4.4.8.2 STT Mechanization

The radar filters ground clutter to enable lookdown operation. When the target is in the clutter (where the target's Doppler frequency falls within the band of frequencies occupied by the clutter aka Doppler Notch), the closure rate is uncertain. When this happens, the closure rates displayed in the upper right of the MFD and next to the target range cue are replaced with the mnemonic COAST. COAST is also indicated by a dashed TD Box and Target Locator Line (TLL) in the HUD/HMCS. In COAST the target position is extrapolated from the last known information (i.e. it is no longer the actual position as in previous versions) and the FCR searches for the target leaving the ground clutter's Doppler region to resume a normal active track. If unsuccessful the FCR will return to the previous search mode.

Currently in BMS a track target will flash after one failed update but is not dropped until 13 seconds have elapsed; the COAST indication happens only 5 seconds before the track is dropped. So there is a period of around 8 seconds when the TD box and TTL in the HUD/HMCS isn't dashed.

With a bugged or STT target the FCR should not drop track when the target exits the FCR gimbals. The FCR will enter COAST as above and the TTL will point to the estimated target position, therefore the TLL can display a number higher than the gimbal limit of 60°. If the target is brought back inside the FCR scan volume within those 13 seconds the FCR will attempt to reacquire a valid track on the target with a high chance of success. If unsuccessful at reacquiring the target the FCR will return to the previous search mode.

If a high line of sight (LOS) target is gimballed and is within 3 NM range, it will be dropped immediately instead of extrapolated. This is helpful in a visual turning fight to avoid having to TMS down (RTS) to stop the FCR extrapolating every time a bandit with a high LOS rate goes outside gimbals.

1.4.4.8.3 STT Mode Switching

The radar can enter STT from any search mode. From RWS or ULS, the ACQ curser is slewed over a search target, then TMS up (designate) and release twice; this bypasses SAM mode. From SAM or TWS, the ACQ curser is slewed over the bugged target, then TMS up and release. Double designating the SAM secondary target, when the radar is in DTT, will cause the newly designated target to become the STT target. From ACM, once a scan pattern has been selected and a target has been detected, STT is automatically entered.

1.4.4.8.3.1 If ACM is selected from STT, or SAM, and the target is outside 10 NM, the target will continue to be tracked at the extended range. When STT is terminated, ACM will revert to the 10 NM search processing.

1.4.4.8.3.2 When RTS is commanded (TMS down in STT), the STT bugged target becomes the SAM primary target and SAM operation is resumed. Two successive RTS commands in STT will result in a transition directly back to RWS. RTS from TWS STT and the STT target becomes the TWS primary target and TWS operation is resumed. If RTS is commanded when the upper level mode is ACM, the radar will return to ACM 20 NO RAD.

1.4.4.8.4 STT Operational Considerations

STT is the mode of choice for retaining a highly accurate track of a single airborne target for weapon delivery, as the antenna beam remains constantly centred on the target. As a result using STT to obtain target information can reveal your position or intent to any enemy with a Radar Warning Receiver (RWR).

STT is best used, therefore, to prosecute an attack once weapon parameters are reached, when you care less about giving away your intentions and more about maximizing the success of your attack.

1.4.4.9 Situation Awareness Mode (SAM)

Situation Awareness Mode (SAM) provides the capability to simultaneously track either a single target (ST SAM) or dual targets (DT SAM) and search a controlled volume of space. The search volume is controlled via the hands-on antenna controls and MFD selected parameters. The search volume may be reduced in azimuth (or even suspended) in order to maintain track on the target(s) of interest.

1.4.4.9.1 SAM Display

The Primary SAM target (also referred to as the TOI or the bugged target) is displayed on the MFD like an STT target. Immediately under the Primary SAM target, the target altitude is displayed numerically in thousands of feet above sea level. In addition, numerical data associated with the Primary SAM target is presented across the top of the display indicating target aspect angle, magnetic ground track, calibrated airspeed and closure rate.

The Secondary SAM target is displayed on the MFD like a TWS system track file. Immediately under the Secondary SAM target the target altitude is displayed numerically in thousands of feet above sea level.

1.4.4.9.2 Scan Coverage

The pilot has control of range and maximum size and location of the antenna scan pattern as in RWS. Typically, the radar displays azimuth scan limits on the MFD indicating the actual scan volume. The azimuth scan limits on the MFD may be less than the pilot-selected scan width because there are occasions when the scan volume is reduced in order to allow SAM to maintain quality tracks on the SAM targets.

In DT SAM, the radar supports the pilot selected scan pattern until one of the targets has a range of less than 10 NM or an AMRAAM has been launched. In either case, the radar will enter the SAM DTT submode where it sequentially updates each of the SAM targets and does not interleave search processing.

Azimuth scan limits are not displayed on the MFD when the radar has entered Suspended SAM Search or DTT. The scan limits are not displayed in order to cue the pilot that the radar is not providing any new situation awareness.

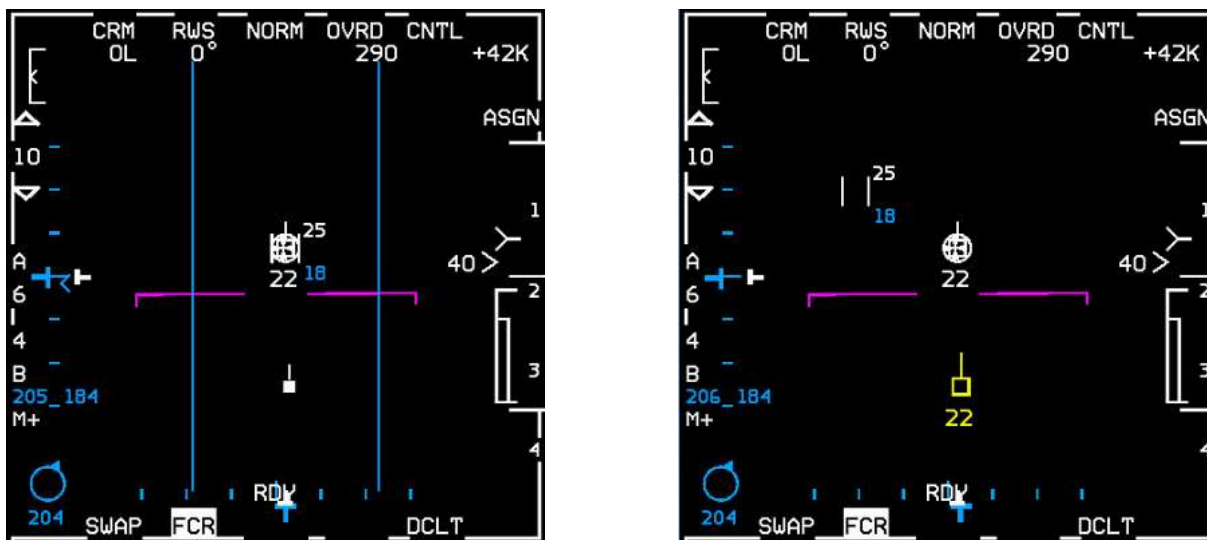

Figure 34 ST SAM entry > auto SAM (left) and DT SAM > DTT submode (right)

1.4.4.9.3 Cursor Control

SAM has the same ACQ cursor control and SAD (Search Altitude Display) capability as RWS when the radar is not in a Long Track Update or the DTT submode of SAM.

Upon ST SAM entry, the acquisition cursor is positioned over the SAM target and the cursor follows the target until the cursor is slewed; this is known as auto SAM and allows for quick entry into STT. Moving the acquisition cursor disables auto SAM and full control of the search area is available; this is known as manual SAM. Search elevation is then centred at the elevation selected by the ANT ELEV knob. A quick TMS forward and TMS down sequence over the SAM target will resume auto SAM.

Upon entry into DT SAM, auto SAM is applied to a target that is upgraded to the target of interest via designating, but not to a target that is upgraded via TMS right. DT SAM simultaneously tracks two targets while maintaining a RWS scan volume centred on the secondary (non-bugged) target.

The azimuth and elevation of the primary SAM target are indicated by the position of the horizontal T-symbol and T-symbol on the left and bottom edges of the MFD respectively.

1.4.4.9.4 SAM Transitions

The SAM submode is entered and exited using the designate (TMS up) and return-to-search (TMS down) commands or by a mode transition to RWS from another air-to-air radar mode. Transition to RWS from another mode will enter ST SAM if there is only one system track file or DT SAM if there are two or more system track files.

The bugged target, if it exists, will always be the primary SAM target. For DT SAM, the primary SAM target is the highest priority target and the secondary SAM target is the second highest priority target.

If the FCR loses the bugged target while in DT SAM, the radar returns to ST SAM and the secondary target becomes the new bugged target. Loss of the bugged target while in ST SAM results in a return to the search mode (RWS or ULS).

1.4.4.9.5 SAM Track

The FCR performs an initial or long track update on a search target that is designated. This track update typically lasts from 1 to 1.5 seconds. Following successful entry into ST SAM or DT SAM, the FCR periodically exits the search phase to perform track update(s). These track updates require approximately one-half second.

There are three conditions when the search processing is interrupted and the FCR will discontinue the search volume:

1. The first of these conditions occurs in ST SAM and DT SAM, as the FCR enters suspended search to dedicate all of the resources to supporting the Primary SAM target. A dedicated track on the SAM Primary target occurs if the Primary target range is less than 3 NM. When the FCR suspends search from DT SAM, the cursors, scan limit lines and secondary target symbol are removed from the display.
2. The second condition occurs when the radar must dedicate all of the resources to supporting the Secondary SAM target. The only time all the resources are dedicated to supporting the Secondary SAM target is when an initial track update is being performed on it.
3. The third condition also occurs in DT SAM when the radar has two targets to support and has entered the dual target track (DTT) submode of SAM. The DTT submode is the submode where the radar performs sequential updates (also known as ping-pong) on the two SAM targets and does not have any search processing interleaved. DTT will be entered when one of the targets has a range of less than 10 NM. The scan lines are removed in this case; however, the cursors remain displayed. See Figure 34 above.

1.4.4.9.6 SAM Target Extrapolation

A radar track will start degrading if the radar doesn't pick it up again within a reasonable (pattern dependent) time frame. If the radar has not detected the tracked target lately (for example in the last 5 paints where the beam passes over the target aircraft but doesn't get a strong enough return) and the radar is coasting (4 seconds since the last actual hit) extrapolation continues. After the coast time the symbol will flash to indicate imminent loss of track status; sometimes you won't see this depending on where the target was in the scan pattern. In this situation the track will disappear unless you get a paint and detection almost immediately.

1.4.4.9.7 SAM Operational Considerations

SAM offers some significant operational advantages compared to the other radar modes. One of its main advantages lies in its usefulness in sorting long range targets. In addition, SAM provides a reduced chance of being detected or considered a threat - especially when compared to STT. Using SAM reduces the time that the radar antenna is directly pointed at the enemy aircraft. Therefore, the probability of revealing ownship position or intent to the enemy may be reduced. Furthermore, if the ownship position is revealed in SAM, the detection may not be considered a threat by the enemy because of the small amount of time the F-16 radar is performing a SAM track.

SAM also provides significant advantages as compared to TWS. SAM provides a more flexible situation awareness capability because the search volume in SAM does not need to include the SAM track targets. In addition, SAM provides a higher quality track on two targets than provided in TWS, especially when the radar is in DTT.

1.4.4.10 ***Air Combat Mode (ACM)***

ACM is designed to automatically acquire aircraft at short range. Four scan patterns, including three referenced to the body of the F-16, allow the pilot to select the most appropriate submode for quick acquisition in STT.

1.4.4.10.1 ACM Display

Search targets and target history settings are not used in ACM since automatic acquisition is employed. The target is displayed on the MFD as a circled triangle and other track information when valid track data is available.

Maximum acquisition range is 10 NM for all ACM submodes. When a target is acquired, automatic range scale switching is enabled. If a target is acquired at (or subsequently moves to) a range greater than 9 NM, the range scale automatically increases to the next larger scale. If a target is acquired (or subsequently moves to) a range less than 8 NM, the range scale automatically decreases to the 10 NM range scale.

1.4.4.10.2 ACM Scan Coverage

There are four scan patterns or submodes available in ACM: 30° x 20°, 10° x 60°, Boresight and Slewable, represented on the MFD below OSB 2 by the mnemonics: 20, 60, BORE and SLEW respectively. They all have in common:

- ACM automatically acquires and tracks the first target detected within submode search range.
- Holding the TMS forward commands BORE and inhibits auto-acquisition until TMS is released.
- ACQ cursor and search target symbols are not displayed.
- While in ACM STT: TMS up, TMS right or CURSOR/ENABLE slew will not cause a radar break lock nor command a new scan pattern.

1.4.4.10.3 30° X 20° Submode

The 30x20 ACM submode is the default selection commanded upon entry into ACM from any other mode. It is body stabilized and searches the entire HUD field of view such that any target seen by the pilot in the HUD should be acquired by the radar in the 30x20 submode. The 30x20 submode can be entered from any other ACM submode by selecting OSB 2 on the MFD.

The 30° x 20° scan pattern searches an area slightly larger than the HUD FOV. The 30° x 20° ACM submode is indicated as follows:

- The scan pattern is referenced to the F-16 body.
- The scan centre is 6° below the HUD bore cross and uses a 4-bar pattern to cover the 30° wide, 20° high area. There is no HUD symbology associated with the 30x20° scan pattern.
- Contact range scale is 10 NM.

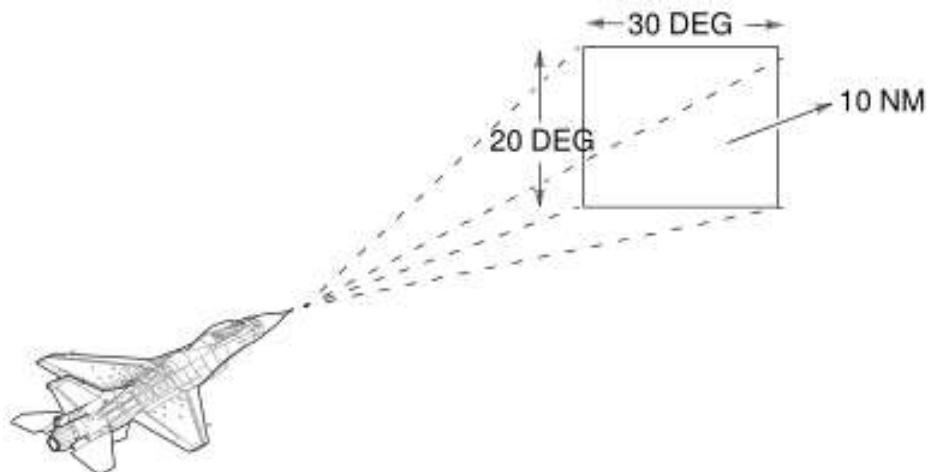

Figure 35 ACM 30° x 20°

1.4.4.10.4 Boresight Submode

The Boresight submode is non-scanning and body stabilized, designed to allow the pilot to point the antenna at a selected single target from a group of targets seen in the HUD. Pressing and holding TMS up inhibits acquisition. Once the desired target enters the cross depicting BORESIGHT coverage in the HUD, releasing the TMS enables acquisition. The BORESIGHT scan pattern searches a one-beamwidth area centred on the F-16 fuselage reference line.

TMS up and hold, while slewing, allows the pilot to slew the BORESIGHT cross and scan pattern within the HUD FOV.

When the FCR is placed in ACM BORE, the FCR can also be slaved to the HMCS Aiming Cross LOS. The FCR is commanded to the HMCS LOS when: ACM BORE mode is selected, the FCR is SOI and TMS up is held.

The BORESIGHT ACM submode is indicated as follows:

- The scan pattern is the antenna beam located 3° below the HUD bore cross.
- A cross is displayed on the HUD with its intersection 3° below the bore cross to aid in positioning the target in the radar beam.
- Contact range scale is 10 NM.



Figure 36 ACM Boresight

1.4.4.10.5 10° X 60° Submode

The 10° x 60° scan pattern searches a narrow volume extending upward from the centre of the HUD and is used in high G situations where the F-16 is pulling into the target. The 10° x 60° ACM submode is indicated as follows:

- The scan pattern is referenced to the F-16 body.
- Scan centre is 23° above the HUD bore cross and uses a 4 bar pattern to cover the 10° wide, 60° high area.
- Total vertical coverage is 53° above to 7° below the HUD bore cross.
- A vertical line extends from the HUD bore cross to the bottom of the HUD.
- Contact range scale is 10 NM.

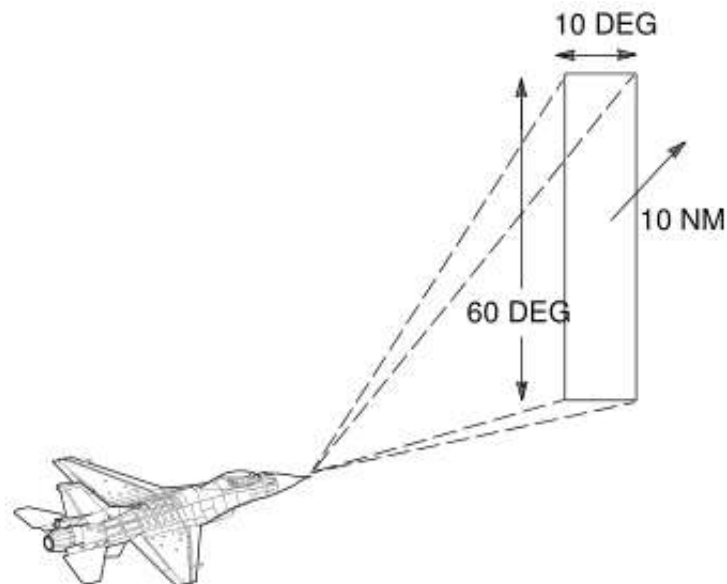

Figure 37 ACM 10° X 60°

1.4.4.10.6 Slewable Submode

The slewable scan pattern is activated and controlled hands-on via the CURSOR/ENABLE control. Scan centre initializes to 0° azimuth and 0° elevation. Further cursor control moves the scan centre. The SLEWABLE scan pattern searches a relatively large area whose centre can be slewed up/down and left/right. It is indicated as follows:

- The scan pattern is space-stabilized in pitch and roll. When the scan centre is slewed, HUD and MFD symbols move in the same directions regardless of the roll angle. The SLEWABLE ACM circle is also locally stabilized.
- The scan pattern is approximately 20° high by 60° wide with scan centre initialized to the horizon and 0° azimuth position.
- Minimum and maximum search altitudes are based on 5 NM range and the position of the scan centre. Search altitudes are displayed in the centre of the MFD and above/below the 8 mR circle on the HUD.
- The antenna-pointing symbol (8 mR circle on the HUD, iron cross symbol on the MFD) is positioned at the centre of the scan. A large cross-positioned at 3° below the boresight cross marks the initialized scan position.
- Contact range scale is 10 NM.

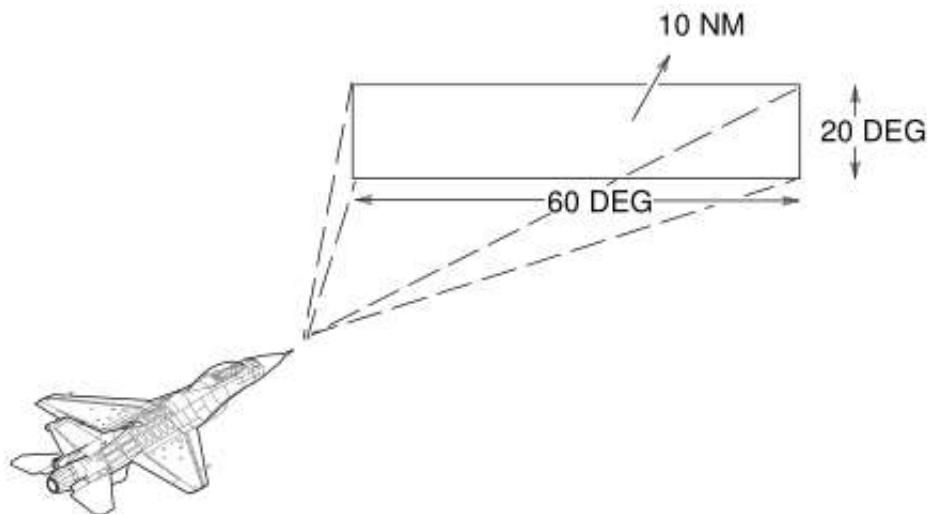
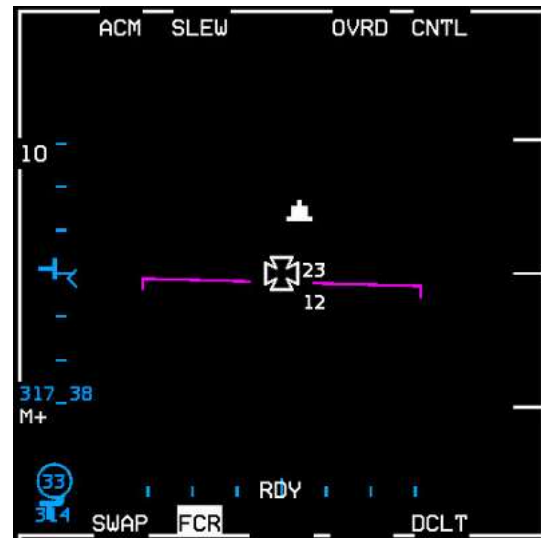

Figure 38 ACM Slewable

1.4.4.10.7 ACM Mode Switching

Upon selecting ACM, 30° x 20° submode is automatically entered. If the radar is not already tracking a target, the transmitter will be turned off and “NO RAD” will be displayed above the HUD Boresight cross. The radar will begin transmitting when any submode is selected.

TMS down is the only switch action that commands a break lock from an ACM track mode.

In any radiating ACM mode, TMS down will drop the current radar track (if there is one) and command 30x20 NO RAD. TMS down again, the radar will switch to 10x60 and radiate. TMS down again to switch to 30x20 NO RAD again. With a track in any of the ACM modes, switching to another mode (with the exception of 10x60) will not drop the current track, but only switch modes, e.g.: BORE mode → TMS right → 30x20.

In BMS 4.34 the DLZ and the IR diamond now also use extrapolated info. Before, if you were in SLAVE, the IR missile would automatically lock (or try to lock) on the FCR target; it usually didn't matter if you had another target closer in the same direction. So in SLAVE, as long as you had tone, you didn't need to uncage at all. Now, in SLAVE, it will look for targets in the same way as it does in BORE, except along the FCR target LOS (line of sight). So make sure you always uncage, and then check the missile is tracking the correct target, before you fire!

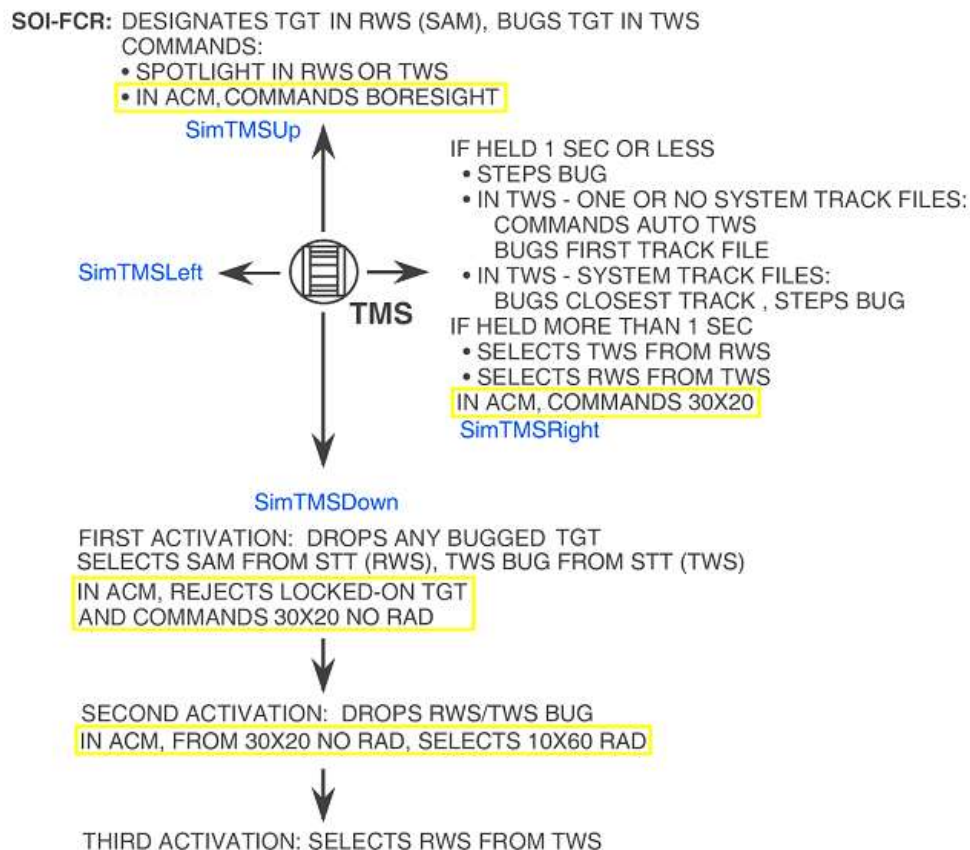

Figure 39 A-A HOTAS TMS functions (FCR SOI) ACM specifics highlighted

1.4.4.11 **AIM-120 Advanced Medium Range A-A Missile (AMRAAM)**

1.4.4.11.1 MFD Symbology

The normal TWS, SAM, STT and DTT display symbology will be maintained during AIM-120 DL. In addition, there will be MFD and HUD symbology related to the launch and control of the AIM-120 missile. This allows head-up or head-down weapon delivery. The symbology on the B-scope when an AMRAAM is in flight is stored when the pilot bugs another contact.

When a slaved AIM-120 is launched against the target, a tail is displayed on the target symbol. The tail flashes at a 3Hz rate when the missile goes HPRF active. A slash is placed over the symbol when the missile goes MPRF active. An X is placed over the symbol at calculated missile impact for 8 seconds. After 8 seconds, the X flashes at a 5Hz rate for 5 seconds and is then removed from the display. When the missile is calculated to miss the target, the word LOSE will alternate with the target altitude at a 3Hz rate.

1.4.4.11.2 AMRAAM mechanization in TWS

The pilot fires on a bugged/priority track/TOI (target of interest) and the normal AMRAAM symbology is displayed. The pilot may then bug another track or TMS right and fire on another track. The first track's symbology will be retained and the track will turn magenta in colour. The pilot may bug additional tracks and shoot missiles. The AMRAAM missile timing information will be retained for all missiles in flight for their respective track files, and displayed for the current bugged/priority track.

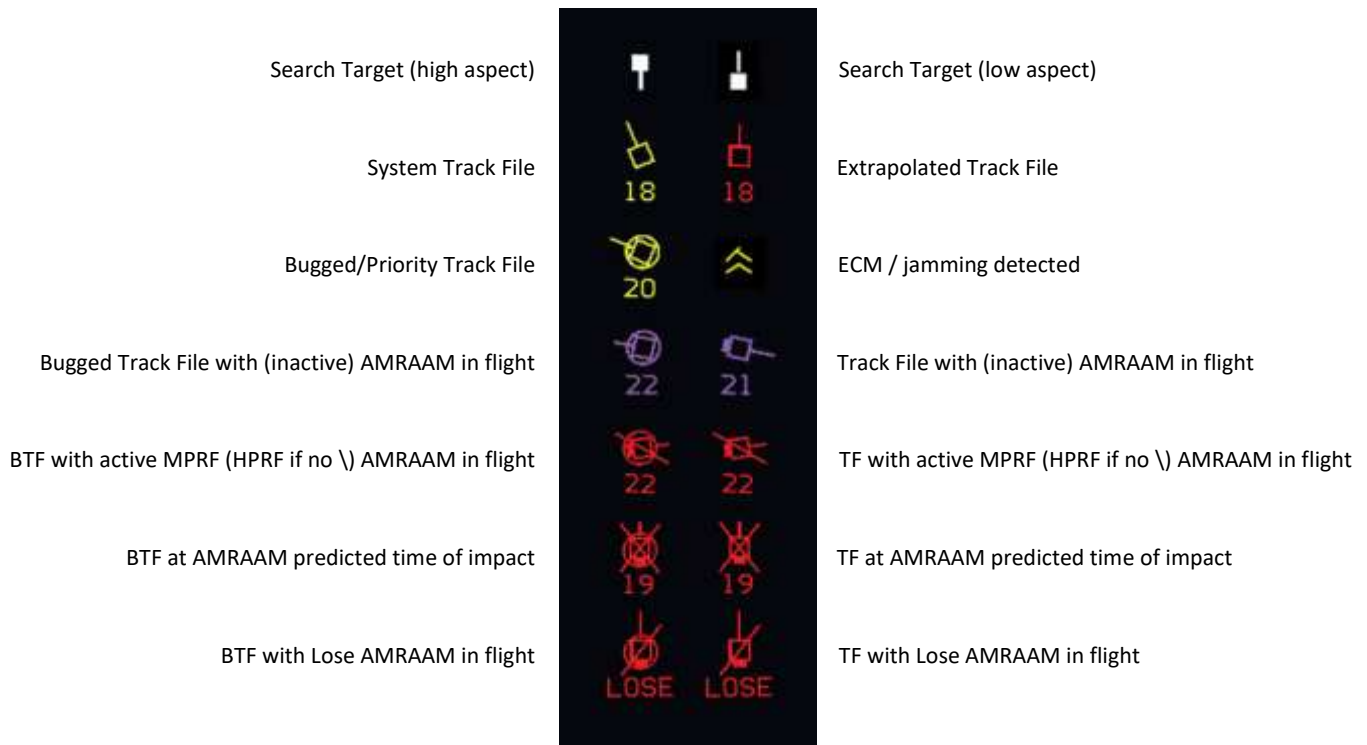

Figure 40 Air-to-Air FCR Symbology

1.4.5 Radar Air-to-Ground Modes

The radar provides A-G modes for ground map, target detection, tracking and air-to-ground ranging. The modes are GM, SEA, FTT, GMT, AGR and BCN (not implemented).

All modes, except air-to-ground ranging, are used to locate preplanned targets presenting a radar return. The ground map video may be expanded, frozen, or have Doppler Beam Sharpening (DBS) applied as aids in positioning the radar cursor over the target. Fixed targets may be acquired and tracked in the GM and SEA modes. The GM mode provides accurate cursor placement on conventional GM video for stationary targets. The GMT mode provides detection of moving ground targets. The SEA mode provides sea clutter reduction in moderate sea states for direct and offset sighting options and fixed target track. The AGR mode provides automatic ranging data for determining height above the target.

1.4.5.1 Air-to-Ground FCR MFD Symbology

A typical A-G MFD display (in Ground Map mode) is shown below:

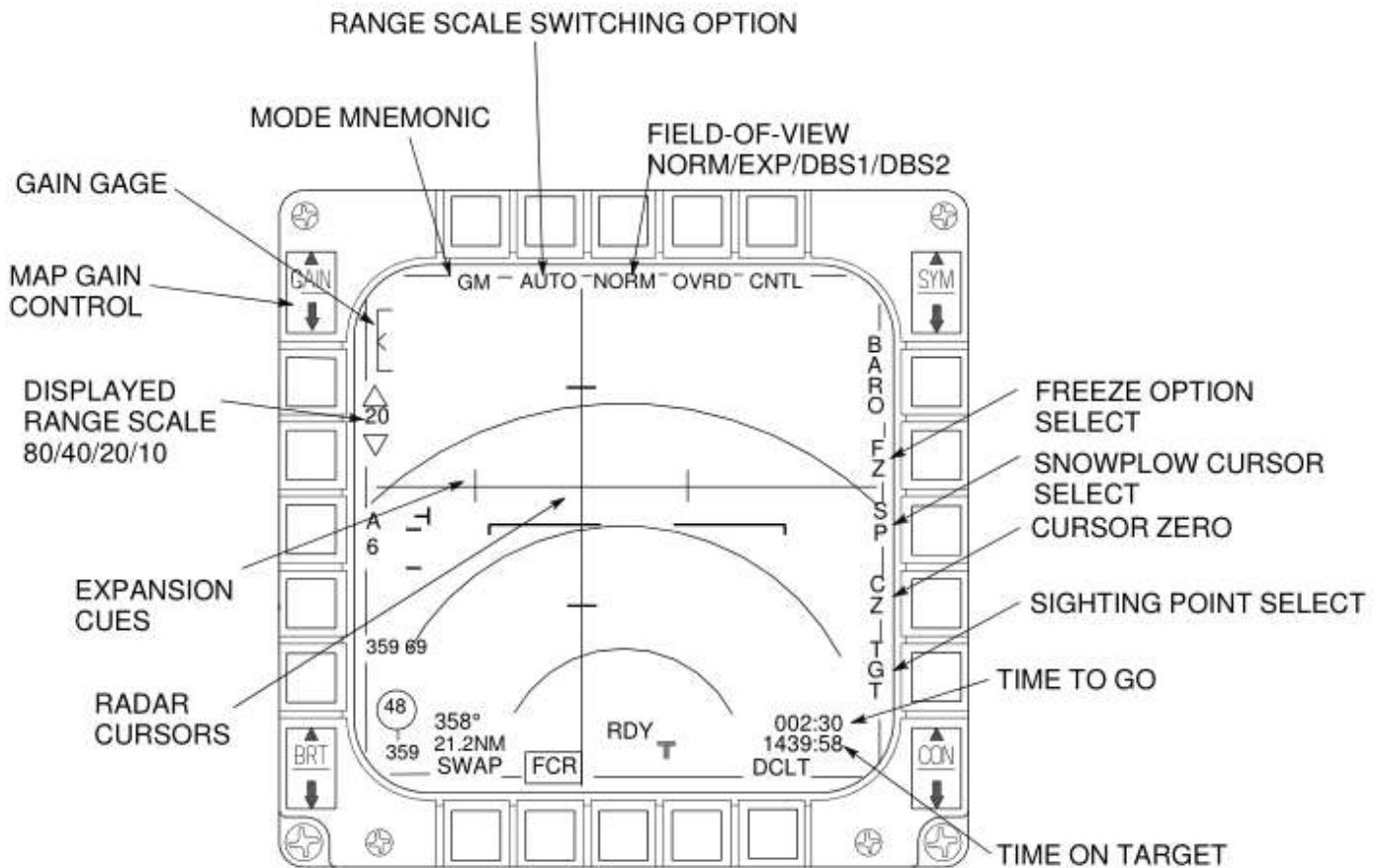

Figure 41 Air-to-Ground (GM mode) Display

1.4.5.1.1 Current FCR Operating Mode (OSB 1)

Possible mnemonics are:

- GM: Ground Map Mode
- GMT: Ground Moving Target Mode
- SEA: Sea Navigation Mode

1.4.5.1.2 Range Scale Selection (OSB 2)

An automatic range scale option is available in the following modes: GM, EXP, DBS1, DBS2, FTT, SEA, GMTI and GMTT. Auto range scale switching is enabled via OSB 2 which toggles AUTO or MAN. AUTO range scale switching, which is on by default, may be disabled by depressing OSB 2 or by manually changing the range scale. Any range scale change made via OSB will return the radar to manual (MAN) range scale operation.

For A-G search operation the AUTO range scale (cursor bump) will increase the FCR range if the cursor is at 95% of the way up the MFD and decrease it if the cursor is at 42.5% of the way up the display, or less. These switch points are shown in Figure 42 below as grey dashed lines. Note the bump will only happen if and when the cursor is not being slewed. This function will allow you to refine the cursor position without interruption if an auto range scale change is required. For FTT and GMTT the target position is the determining factor in changing range scales.

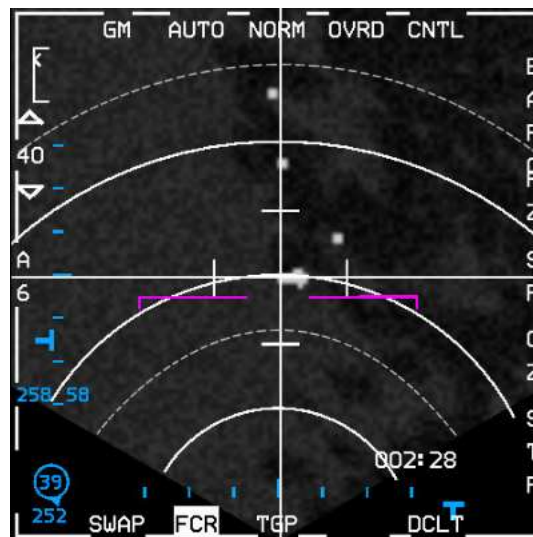

Figure 42 Auto Range Scale Switch Points

1.4.5.1.3 Field-of-View (FOV) Options (OSB 3)

In all A-G mapping modes the expanded (EXP) FOV option is available. Selection of EXP FOV results in a 4:1 range and azimuth expansion of the patch of map surrounding the cursor position.

- 1.4.5.1.3.1 For GM mode only, two Doppler Beam Sharpening (DBS1 and DBS2) FOV's are also available. Selection of DBS1 will provide the same FOV as with EXP, but with improved resolution (8:1). DBS2 will provide a FOV roughly double that of EXP and DBS1 with improved resolution (64:1). Either the EXPAND/FOV button on the stick or OSB 3 above the FOV mnemonic can be used to select the available FOV's in A-G mapping modes.

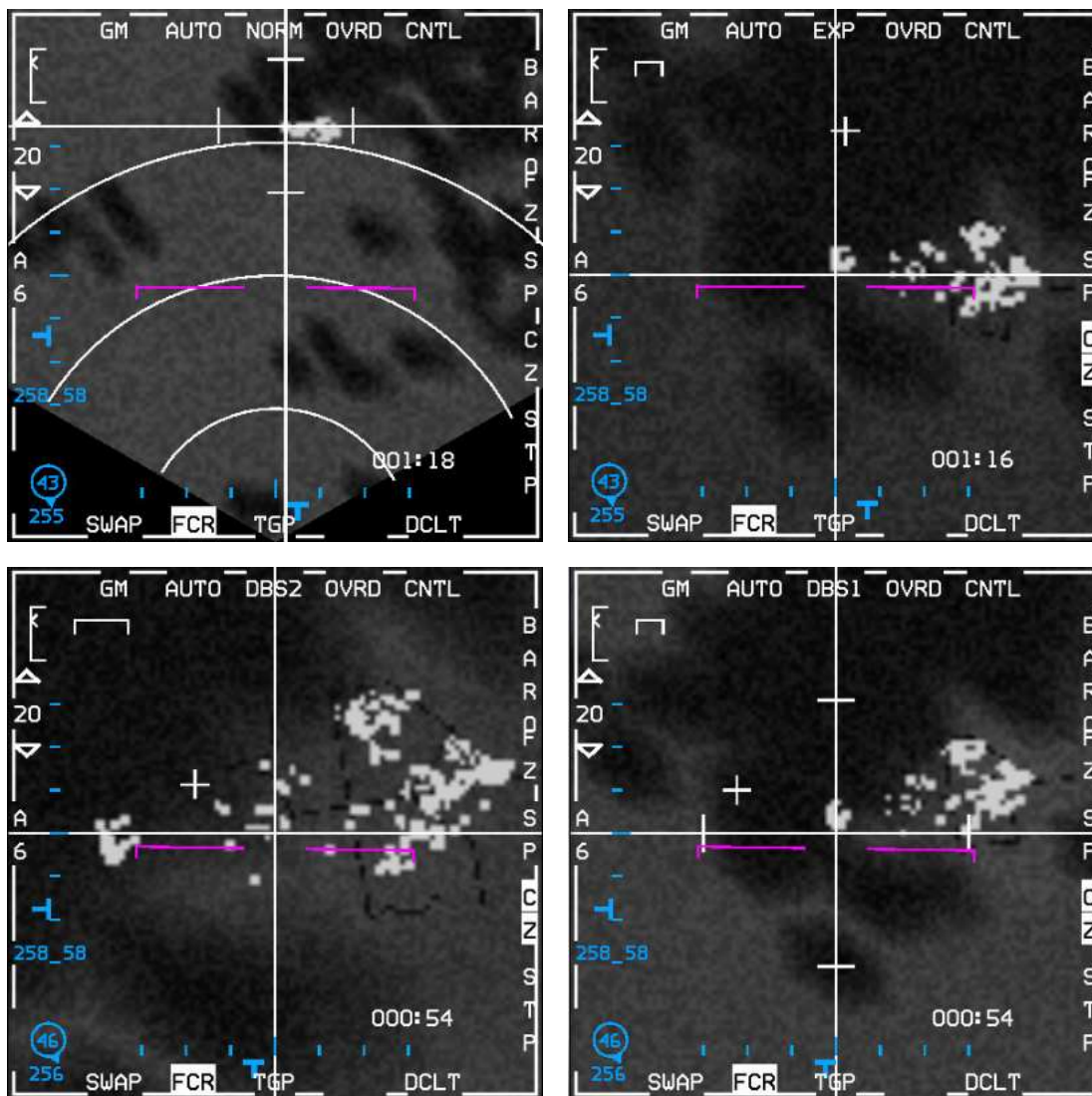

Figure 43 GM FOV options (clockwise from top left: NORM, EXP, DBS1 and DBS2)

- 1.4.5.1.3.2 Expansion Cues. In the normal GM, SEA and GMTI displays, four expansion cues (tick marks) are provided on the X-Y cursors to define the area that would be displayed upon selection of the EXP FOV. Similarly, in the GM mode, when the DBS1 FOV option has been selected, expansion cues will be provided to define the area that will be displayed upon selection of DBS2. (See Figure 43 above - note the cursor was slewed to the right and up to encompass the whole area of interest before the screenshot was taken for the DBS2 image above.)
- 1.4.5.1.3.3 Situation Awareness Symbol. In any of the expanded ground map type mode FOV options including DBS1 and DBS2, a situation awareness symbol (a thin cross) will be positioned on the display to show where the X-Y cursors would be upon return to the unexpanded (NORM) display. This may be used to determine range to the selected sighting point.
- 1.4.5.1.3.4 Quarter Mile Scale Reference. In any of the EXP FOV options including DBS1 and DBS2, a horizontal line is displayed in the upper left-hand corner of the display to indicate a length of 0.25 NM (1500 feet).

1.4.5.1.4 Standby Override Select/Deselect (OSB 4)

“OVRD” selects FCR standby.

1.4.5.1.5 FCR Control Page Select (OSB 5)

“CNTL” selects the FCR control page.

1.4.5.1.6 Backup Bombing Sensor (BBS) (OSB 6)

The Backup Bombing Sensor (BBS) is not currently implemented in BMS.

1.4.5.1.7 Freeze (FZ) Submode (OSB 7)

The FZ option terminates radar transmissions although the antenna continues scan movements. A frozen map display suitable for navigation and weapons delivery is retained. The pilot can still refine cursor position. With a patch of the PPI sector frozen, cursor refinements result in the movement of the vertical and horizontal lines depicting cursor position relative to the map. An aircraft position symbol, depicted as a bold cross, is displayed on frozen scenes and is continuously updated. This symbol represents the position of the aircraft relative to the frozen scene; that is, the symbol appears over that point on the map that is presently directly beneath the aircraft. The FZ option may be deselected by changing the FOV, changing the FCR mode, or by depressing the FZ OSB again.

1.4.5.1.8 Snowplow (SP) Submode (OSB 8)

Depress OSB 8 next to the SP mnemonic to select the snowplow option. The mnemonic highlights indicating that you are in SP mode. SP sighting directs each sensor line-of-sight straight ahead in azimuth; it is not referenced to any steerpoint. In GM, GMT and SEA modes, the cursor will be positioned in the centre of the MFD. The cursors remain fixed while the ground map video moves, or "snowplows," across the MFD.

At this point, there is no sensor of interest (SOI) and the cursors cannot be slewed. TMS up establishes the radar as SOI, ground-stabilizes the cursor and enables cursor slewing with the CURSOR/ENABLE switch. TMS up again with the cursor over a target will command target track. All cursor slews in SP are zeroed when SP is deselected.

After ground stabilizing, the point under the cursors at the time of stabilization effectively becomes your steerpoint. All NAV and weapon delivery steering and symbology, including great circle steering, will be referenced to this "pseudo steerpoint." Displays return to the previously selected sighting point when SP is deselected.

TMS down will only drop a ground target lock, placing the cursor at the same point it was before a lock attempt was made.

SP is deselected any of the following ways:

- Depressing OSB 8 adjacent to the SP mnemonic.
- Entering any air-to-ground visual submode (CCIP, DTOS, STRAFE, EO-VIS).
- Changing steerpoint (only if SP is ground stabilized; pre-designate changes of steerpoint have no effect).
- Entering any air-to-air radar mode.

As SP mode is not tied to a steerpoint it is particularly useful where target coordinates are not known in advance; either because specific enemy battalions are on the move, or for finding targets of opportunity. It can also be useful to scan ahead for potential ground threats or terrain obstacles while navigating, especially at low altitude.

1.4.5.1.9 Cursor Zero (CZ) (OSB 9)

Depressing the OSB adjacent to the CZ mnemonic will zero accumulated A-G cursor corrections (slews). This mnemonic is available on all A-G FCR base pages, TGP base pages and OFF pages when in A-G or NAV master modes. See also 3.1 SPI MANAGEMENT.

1.4.5.1.10 Sighting Point Rotary (OSB 10)

The sighting point rotary determines the System Point of Interest (SPI). Depressing OSB 10 adjacent to one of the following mnemonics selects the next available option in the rotary. Depressing TMS right will accomplish the same thing if the SOI is the HUD or FCR (and the radar is in air-to-ground mode). This causes the tracking sensors to break lock and select the next option in the rotary just as the OSB does.

- TGT/STP - TGT or STP sighting, positions the cursor directly over target or steerpoint; i.e., destination coordinates plus cursor corrections are at the entered target location when using VRP sighting. The option selected is a function of the operating mode or submode.
- OA1/OA2 - OA1 or OA2 positions the cursor at the entered range and bearing from the selected steerpoint. If an offset aimpoint has a range of zero, it will not be in the sighting point rotary.
- IP/RP - If the selected steerpoint is equal to the initial or reference point, the selected IP or RP sighting option causes the cursor to be directly over the IP or RP. The option selected is a function of the operating mode or submode.

The air-to-ground tracking sensor will break track when the sighting point rotary is changed by the MFDs.

1.4.5.1.11 FCR A-G Declutter Select/Deselect (OSB 11)

When the DCLT OSB is depressed selected items are removed from the MFDs. Declutter is deselected by depressing the DCLT OSB a second time.

1.4.5.1.12 TTG, TUI, and TOF on FCR (above OSB 11)

The FCR STBY, BIT, A-G Base page, and A-G Ranging (AGR) page (as well as the HSD and TGP) display the appropriate time-to-go (TTG), time-until-impact (TUI), and time-of-flight (TOF) information in the lower right corner. Time-on-target (TOT) depiction is placed directly below the time-to-pull-up/time-to-impact data.

1.4.5.1.13 Bearing and Range to System Point of Interest (SPI) (above OSB 15)

In any GM mode, location of the SPI is provided in two digital formats on the MFD. If the mode-selectable bullseye is not selected, the location of the SPI relative to the system STP is displayed above the backup steering symbol (flying W) on the MFD. If the mode-selectable bullseye has been selected, the flying W is replaced by ownship bullseye symbology, the same as on A-A FCR displays. Location of the SPI is then displayed relative to the bullseye. In either case, location of the SPI relative to ownship is also displayed to the right of the flying W or ownship bullseye symbology.

1.4.5.1.14 Azimuth Scan Pattern (OSB 18)

In all A-G mapping modes, the antenna azimuth scan pattern is initialized at $\pm 60^\circ$. OSB 18 will cycle through the available antenna azimuth scan patterns; A1, A3, or A6 for $\pm 10^\circ$, $\pm 30^\circ$, or $\pm 60^\circ$ azimuth scans respectively.

1.4.5.1.14.1 Antenna Azimuth Symbol. The radar antenna angle in azimuth is indicated by a T-symbol that moves along the bottom of the MFD display. The azimuth angle of the antenna is estimated by observing the position of the azimuth caret relative to the display width, which represents $\pm 60^\circ$ in unexpanded displays (in A-G modes, 0° is along the aircraft ground track).

1.4.5.1.15 FCR Range Display (OSB 19-20)

FCR range scale with \triangle ∇ (INC/DEC) switches are displayed.

1.4.5.1.16 Gain Control

The GAIN rocker switch, located at the top left of the MFD, adjusts the map gain around the default gain established by the radar. Hands-on gain adjustment is available by rotating the MAN RNG/UNCAGE control. The map gain is increased or decreased by approximately $\pm 20\%$ of the base setting when the knob is rotated.

In order to provide additional gain, an indicator is displayed top left, next to the rocker switch. With maximum gain, the caret will be located at the top of the indicator; with minimum gain, the caret is located at the bottom.

1.4.5.1.17 Elevation Scan Pattern

Elevation scan pattern is not selectable in A-G modes. The scan pattern is a 1-bar scan except when in FTT, GMTT, or AGR.

1.4.5.1.17.1 Antenna Elevation Symbol. The radar antenna angle in elevation is indicated by a horizontal T-symbol that moves up and down the left side of the MFD display. The elevation angle of the antenna is estimated by observing the vertical position of the elevation caret relative to the display height, which represents $\pm 60^\circ$.

1.4.5.1.18 Range Marks

For unexpanded GM-type modes, the range marks consist of a series of concentric arcs. The number of range marks is a function of the selected range scale as follows:

<u>Range Scale</u>	<u>Range Marks</u>	<u>Miles/Mark</u>
10	1	5
20	3	5
40	3	10
80	3	20

1.4.5.1.19 Ground Target Track

In GM, SEA, and GMT modes, if a target is being tracked, the target will appear as a solid diamond at the intersection of the X-Y cursor and range will be displayed in the HUD slant range window.

1.4.5.2 **Ground Map (GM)**

GM mode is designed to provide a map display on the MFD suitable for navigation and for target detection. Weapons delivery is supported by a ground stabilized cursor whose position is indicated on the map display and is used to centre the scan coverage. GM returns are displayed on a plan position indicator (PPI) (polar coordinates) sector format. The submodes EXP, 8:1 DBS1, and 64:1 DBS2 magnify a patch of the PPI sector resulting in increased resolution of the map and more precise cursor placement. See Figure 43 for all available expanded FOV options.

Transition to FTT is available from GM NORM, EXP and DBS.

STP, OA and SP cursor position are used for weapons delivery and centring of the map coverage. A STP, OA or SP can be selected as an initial cursor position. STP and OA information is used to continually determine the cursor range in all three axes from the aircraft to the STP. Therefore, the cursor is ground stabilized at that location.

SP allows observation of the map area in front of the aircraft without having to constantly select steerpoints located ahead of the aircraft. Pressing TMS up creates a pseudo-steerpoint at the current cursor position. At this time, cursor position is ground stabilized, similar to selecting a steerpoint for the initial cursor position, and cursor placement may be adjusted.

Cursor position is depicted relative to the map at the intersection of the horizontal and vertical lines on the MFD and is also indicated by the steerpoint diamond in the HUD. The CURSOR/ENABLE control is used to move the cursor onto the feature of interest on the displayed map.

Pressing CZ on the MFD removes previous adjustments made to the initial A-G cursor position. This is useful if adjusting gain, changing submodes, or lowering range scale. In this case, the A-G cursor may be displaced from the correct position over the target.

Scan pattern size and location in GM are controlled both automatically and manually. A 1-bar scan is roll and pitch stabilized with ± 10 , ± 30 , or ± 60 azimuth scan width selections available from the MFD.

Range resolution increases by 2:1 for each decrease in range scale while in the NORM, EXP and DBS1 submodes. Changing range scales in DBS2 has no effect on range resolution.

1.4.5.3 **SEA**

SEA mode is designed to detect sea-borne targets in low sea states. SEA mode processing differs from GM in that more samples are integrated to produce the map. This requires a slightly slower scan rate to increase the integration time on sea targets.

Control and operation of SEA mode is identical to GM except for the processing differences described above, and the lack of DBS submodes. The NORM and EXP submodes are available as well as the FZ option and transition to FTT.

1.4.5.4 Fixed Target Track (FTT)

FTT is designed to automatically maintain an accurate track of a stationary discrete target for weapon delivery. FTT is available in GM, SEA or DBS modes and is initiated with a TMS up. This action initiates an acquisition sequence where the radar searches for targets about the cursor position with greater reflected intensity than the background clutter.

1.4.5.4.1 Multifunction Display (MFD)

Track targets on the MFD are displayed as a solid diamond. The lines previously used to indicate cursor position now indicate target position with the solid diamond at the intersection. The range rings and expansion cue are not displayed during FTT. A typical FTT display is shown below:

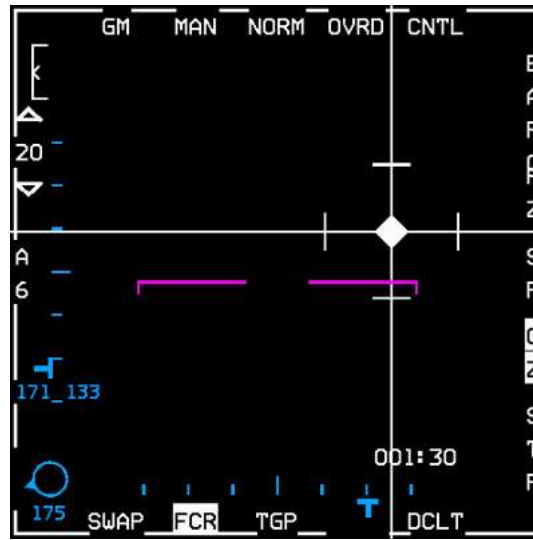

Figure 44 FTT display

1.4.5.4.2 Head-Up Display (HUD)

FTT targets can be seen visually through the HUD. For weapon delivery, an A-G TD box is positioned at the target location. Slant range to the target is also presented on the HUD.

1.4.5.4.3 FTT Acquisition

Transition to FTT is available from all GM submodes (NORM, EXP, DBS1, and DBS2). If the SP option is selected, the cursor must first be ground stabilized before acquisition of a target can be attempted. The pilot first selects a discrete ground return to track in FTT. Accurately slewing the ground stabilized cursor to the target and pressing TMS up and release designates the target and initiates the acquisition process.

If acquisition is successful, then the lines previously indicating cursor position now indicate the tracked target position, with a solid diamond placed at the intersection. The FTT display format is a PPI sector similar to the GM NORM submode, but without the map information, range rings or expansion cues.

It is generally preferable to acquire targets from EXP or DBS, since signal and thus image quality is increased, and it is easier to differentiate targets.

1.4.5.4.4 Loss of Track

If FTT processing can no longer detect the target, or track is terminated due to signal fade, the cursor on the MFD is placed at the last tracked position.

Return to search is commanded by TMS down. FTT is stopped and the previously selected search mode is resumed, with the FOV option in effect at the time of designate. The cursor on the MFD is placed at the last tracked position.

FTT is exited and the previously selected search mode is resumed when the antenna reaches its mechanical gimbal limits. The cursor on the MFD is placed at the gimbal limit position.

1.4.5.4.5 Mode Switching

Changing to any other mode while in FTT results in an immediate mode change and the track is terminated.

1.4.5.5 **Ground Moving Target (GMT)**

GMT mode is designed to detect moving targets on land or sea. Moving vehicles including cars, tanks, trucks, ships, aircraft while taxiing or helicopters in flight can be detected at low speeds. A background map is available for navigation and detection of stationary targets. Normal (NORM) and expand (EXP) submodes are available along with the FZ option similar to GM.

Acquisition to Ground Moving Target Track mode (GMTT) is available for tracking moving targets in the real APG-68; however, in BMS it is not currently modelled. Targeting pods (AN/AAQ-14 LANTIRN or AN/AAQ-33 Sniper) will allow you to acquire and track moving vehicles once detected with GMT mode.

1.4.5.6 **Air-to-Ground Ranging (AGR)**

The AGR mode is designed to provide accurate range to a ground point for visual A-G delivery modes (CCIP, DTOS, STRAFE, EO-VIS). The radar is automatically commanded to AGR when the appropriate A-G weapon submode is selected (unless STBY or OVRD is selected).

AGR ranges to the point on the ground indicated by weapons delivery symbology in the HUD. Depending on the submode selecting AGR, the symbol in the HUD may be slewed to the desired point, or the aircraft can manoeuvre to place the symbol at the desired point, or a combination of both. The CURSOR/ENABLE switch on the throttle is used to slew the symbol. Different symbols (see below) are used to indicate the ranging point depending on the submode.

Submode	Symbol	Pointing Method
HUD Mark	CCIP Pipper (circle with dot)	Slew
Visual Air-to Ground STRAFE CCIP	CCIP Pipper (circle with dot)	Manoeuvre aircraft
DTOS EO-VIS	A-G TD Box (square with dot)	Manoeuvre aircraft Slew

1.4.6 FCR Faults

Table 4 FCR Faults

PFL	MFL	EFFECT	ACTION	LIGHTS
FCR BUS FAIL	FCR 003	FCR INOPERATIVE	N/A (NOT RECOVERABLE)	AVIONICS FAULT
FCR XMTR FAIL	FCR 094	FCR INOPERATIVE	N/A (NOT RECOVERABLE)	AVIONICS FAULT

1.5 IMPROVED DATA MODEM (IDM)

1.5.1 Background

The MD-1295A Improved Data Modem (IDM) provides the capability to transmit and receive air-to-air and air-to-ground data link messages between aircraft (intraflight).

The IDM is essentially a wireless digital modem that operates in conjunction with on-board radios and the rest of the avionic system to provide data communications with other users. In order to communicate with each other, each user must have an IDM terminal that is operating on a radio tuned to the same frequency and has compatible initialization parameters set. The IDM converts digital data to audio data for UHF or VHF radio transmission. When data is received from other users, the IDM converts the audio data to digital data and sends it to the avionics system for display in the cockpit.

The IDM in the F-16 helps the pilot increase situational awareness (SA) by providing the ability to pass positional information about each jet in the flight to all flight members, to target flight members on to specific air or ground targets, to easily execute tactics outside the visual arena and to more easily regain visual mutual support should a flight member become a “lost wingman”.

1.5.2 Data Link Operation Overview

The Data Link system allows up to 8 IDM equipped aircraft to transmit and receive intraflight data link messages.

Data link transmissions are initiated using the 4-position COMM switch on the throttle. Depressing the COMM switch inboard transmits air-to-ground information and COMM switch outboard transmits air-to-air information.

For HOTAS Cougar users, SimCommsSwitchLeft (used for A-A operations) should be programmed to the “IFF OUT” switch and SimCommsSwitchRight (used for A-G operations) should be programmed to the “IFF IN” switch. This is set up by default with the profile included in the `\Docs\01 Input Devices\03 HOTAS Setup\TM Cougar` folder. For other joystick users, it is highly recommended to have these programmed as well to allow easy hands-on control.

Note: IDM operates over VHF or UHF radio, so you cannot transmit on VHF or UHF and send/receive data link transmissions over the same radio at the same time.

Transmitted air-to-air information consists of ownship position, altitude, velocity, magnetic ground track, flight member number, and the position of the ownship’s bugged target.

Air-to-ground data link information consists of the selected steerpoint which may be a markpoint, a navigation steerpoint, or the FCR air-to-ground cursor position.

Air-to-air and air-to-ground data link information may be selected for display on the HSD MFD format by selecting ADLINK (OSB 16) and/or GDLINK (OSB 17) on the HSD Control page (both are on by default). When ADLINK is selected, intraflight member’s ownship positions and the locations of their bugged targets are displayed on the HSD. This same symbology is also displayed on the FCR, provided the FCR is in one of the air-to-air radar modes.

When GDLINK is selected, data linked steerpoint (or markpoint) and FCR air-to-ground cursor positions will be displayed on the HSD.

1.5.3 Data Link Symbolology

The data link symbolology displayed on the HSD is shown in Figure 45 below.

- Data Link Friendly. Wingmen are displayed on the HSD by a half circle with a line projecting from the top of the half circle. The symbols are oriented on the HSD based on ground track. Flight member number is displayed at the top of the symbol and altitude is displayed at the bottom of the symbol.
- Data Link Unknown. Ownship and wingmen's bugged targets are depicted as half squares with a line projecting from the top half of the half square. Flight member assignment number and target altitude are displayed at the top and bottom of the symbol, respectively.
- Data Link Targets (see Figure 48). Outside the HSD FOV. Data link friendly or data link unknown targets which are outside of the HSD field-of-view are indicated by an arrow pointing in the direction of the target positioned on the outer range ring of the HSD.
- Data Link Steerpoints (see Figure 51). Are stored in steerpoints 71-80. Ownship markpoints are shown as a big X. Datalink steerpoints are shown as a small x. If you select one as your active steerpoint the X or x will be highlighted in inverse video.
- Data Link FCR A-G Cursor Position (see Figure 52). The data link A-G cursor position is displayed on the HSD as an asterisk with the sending flight member's number above it.

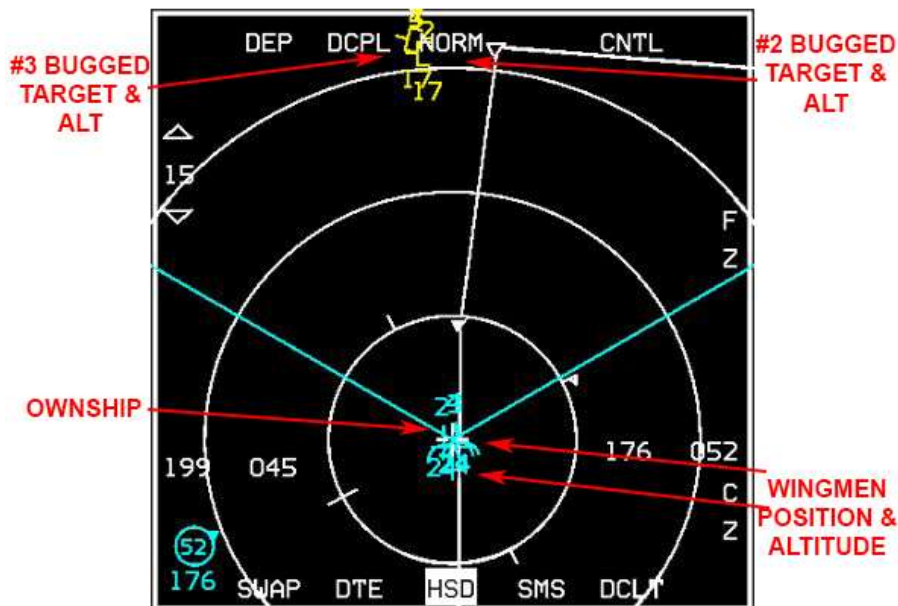

Figure 45 HSD Data Link Symbolology

1.5.4 Data Link Initialization via the UFC

In order to effectively exchange information, each participating data link user must have compatible parameters initialized into his respective IDM terminal. In Falcon BMS, initialization parameters are automatically fed into the IDM, to an extent.

Ownship team address numbers and other flight member team addresses are done for you. These addresses are for you and the rest of your flight. The additional team addresses 5-8 are not filled in and must be keyed in manually, based on pilot preference, or as briefed by your flight lead or package commander. This will be discussed later. IDM initialization through the DTC is not implemented. Using the UFC (Up-Front Controls) the pilot can confirm and manually change a number of IDM parameters.

The first step in initializing the system is to position the Data Link power switch located on the AVIONICS POWER Panel to the DL position.

Once powered up, LIST → ENTR will select the A-G DL page. There are now 4 selectable options on this page:

- **COMM** (UHF/VHF) – this option toggles which radio A-G datalink messages will be transmitted over. Note: everyone must be on the same frequency, whichever radio is used. By default VHF is used for A-G datalink, with UHF used for A-A (INTRAFLIGHT) datalink messages. This can be toggled by moving the * * asterisks around VHF/UHF using the DCS switch and pressing a number key 1-9 on the ICP.

Note: while humans can use any radio/frequency, AI are always on UHF TACTICAL (UHF PRESET 6 by default).

- **XMT** (Transmit Address) – this is the address (0-99) of the aircraft you want to send the datalink message to. By default this is set to broadcast (multicast) to all members of your flight.

The transmit address on the A-G-DL page represents a unique destination address sent in every A-G datalink transmission. The destination address indicates which receiving IDM will process the message by specifying its address. All IDMs will receive the message, but will ignore it if not addressed to them.

Transmit addresses that end with a 0 are used to multicast to groups or teams with the same first digit in their ownship address, e.g.: the 1st flight in a package will be 10, the 2nd flight will be 20 and so on.

0 is used to broadcast to *all* IDMs that are tuned to the same radio frequency.

- **OWN** (Ownship Address) – this is the address of your aircraft and follows the same format as above, e.g.: flight lead of the 1st flight in a package will be set up by default as 11, his/her wingman will be 12, the element lead 13 etc. The address range is from 11-99.
- **FILL** (ALL/NONE) – The FILL option determines whether the system stores (ALL) or ignores (NONE) any received data link steerpoints (71-80). By default ALL is selected and the system will store the first message in STPT 71 and fill each subsequent STPT until it hits 80, then it will wrap around to the oldest location (71) and overwrite that data. When NONE is selected, no HUD or VMU (Voice Message Unit) messages are provided for these messages. The FILL option has no impact on A-A intraflight or A-G cursor messages; they will be processed normally.

Sequencing right with the DCS switch (SEQ) changes to the INTRAFLIGHT page, where team addresses can be reviewed and changed.

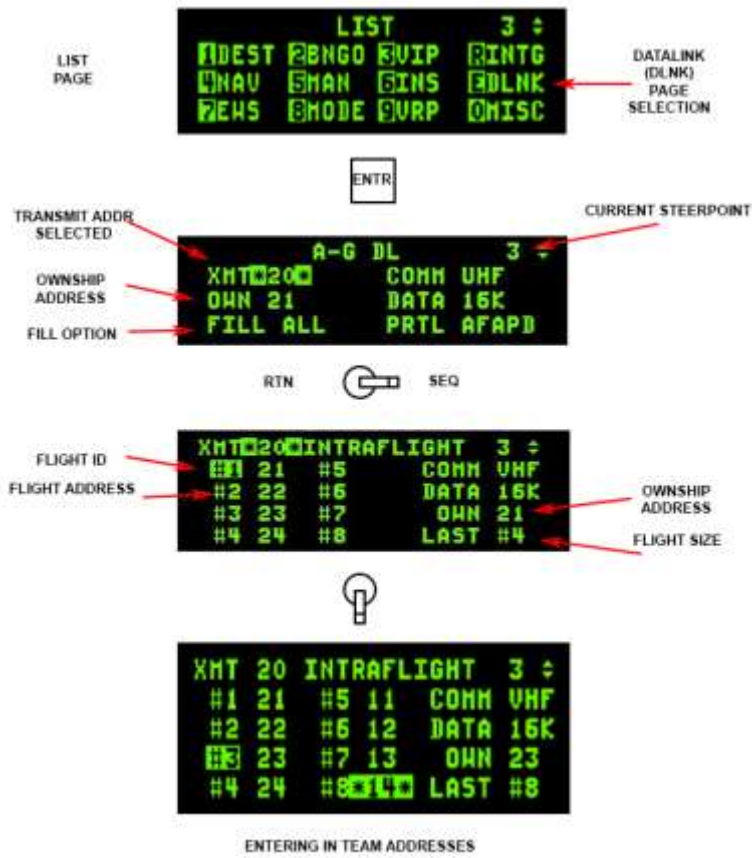

Figure 46 Data Link Initialization Pages

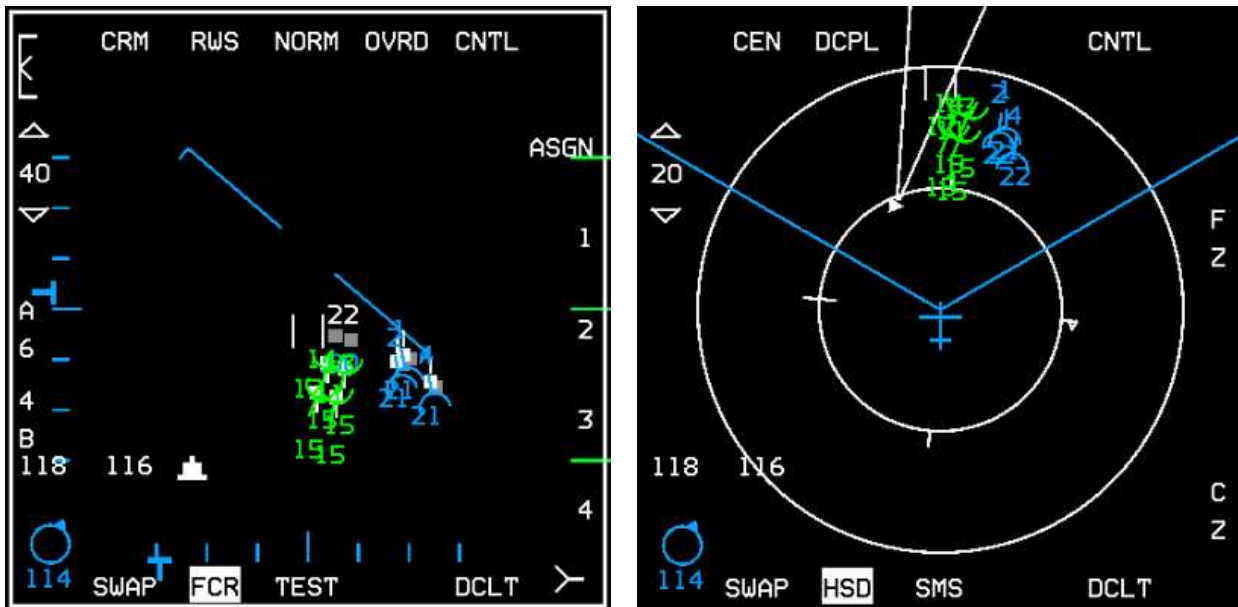

Figure 47 All IDM addresses filled and displayed on FCR and HSD

1.5.5 Air-to-Air Intraflight Data Link

The A-A intraflight data link has 3 modes selectable by the pilot to assist in situational awareness and employ coordinated support and targeting of airborne targets: Demand (DMD), Assign (ASGN) and Continuous (CONT).

Note: to send/receive data link updates with AI you will need to be on their UHF TACTICAL frequency (UHF preset 6 for that flight). Data link with humans can be done on any valid frequency, on either radio. The Data Link switch located on the AVIONICS POWER Panel must be in the DL position for the system to function.

1.5.5.1 Modes of Operation

1.5.5.1.1 Demand Mode Operation

The Demand (DMD) and Assign (ASGN) data link modes allow a team member to obtain a “one-shot” team situational awareness update (an intraflight transmission round) on an “as needed” basis. The DMD and ASGN modes also enable the option to make assignments to other flight members. When the IDM is in DMD or ASGN mode and is commanded to transmit, the IDM transmits an A-A Request message to the intraflight team (up to four jets in a flight). The request message contains current aircraft position, heading, and velocity.

If an FCR target of interest (TOI) is available at the time of transmission, the position, heading, and velocity of the TOI is also sent in the request message. Each receiving aircraft then transmits an A-A Reply message (in turn based on their sequential order requested by the request message). The A-A Reply message contains ownship and TOI data similar to the request message. The messages transmitted allow each member to see the positions and headings of other members and their bugged target on the HSD page and FCR page.

Both A-A Request and A-A Reply messages are snapshots in time. For example, once the pilot’s IDM receives A-A Reply messages, the wingmen team symbols (cyan-coloured unless High Contrast MFDs option is selected (Figure 47) with the Configuration tool) and their bugged targets are extrapolated for 8 seconds. Once this extrapolation period ends, the symbols will disappear and another data link round must be initiated by a team member (unless CONT mode is used). If heavy maneuvering occurs during an extrapolation period, the next transmission round may result in wingmen symbols and their bugged target symbols jumping on the displays (HSD and FCR) to their new location.

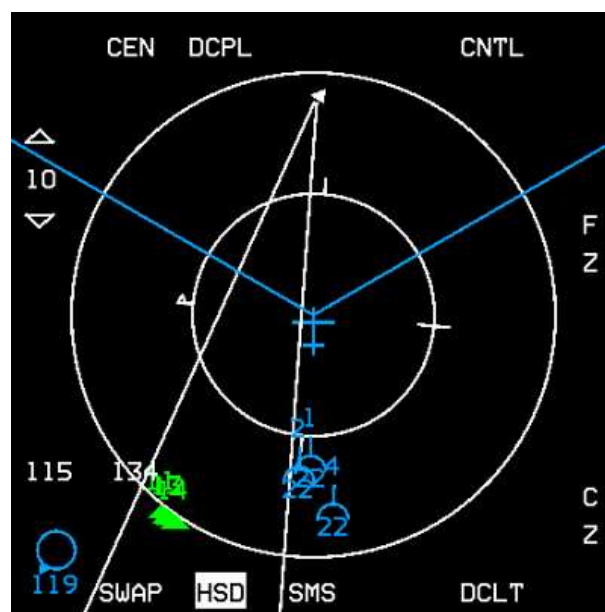

Figure 48 Friendly wingmen off HSD (bottom left)

The following applies to the initiation and verification of a successful data link transmission round:

2. Verify data link mode DMD or ASGN is displayed next to OSB 6 on the A-A FCR. Press OSB 6 if necessary to cycle through the modes.
3. Depress COMM switch left for >0.5 sec (on the throttle if you have them programmed on the Cougar, else "Delete" or whatever keystroke you have them assigned to); verify DMD or ASGN mnemonic is highlighted for 2 seconds.
4. Verify display of intraflight data link symbology (i.e., your wingmen team members) on the HSD when the reply messages are received from team members.
5. Verify display of intraflight data link symbology on the A-A FCR page when the replying team members are in front of ownship.
6. To declutter A-A intraflight data link symbology on the FCR page, depress COMM switch left for <0.5 sec. The decluttered state will remain until you depress COMM switch left for <0.5 sec again.

The following applies to making a data link A-A assignment:

1. Ensure the system currently has a FCR TOI (Target of Interest).
2. Depress the OSB (7 through 10) adjacent to the ID associated with the assignee team member (addresses in slots #1, 2, 3, or 4 on the INTRAFIGHT page); verify assignment ID is replaced by highlighted "XMT" mnemonic for 2 seconds.
3. Verify display of the team member ID above the FCR target symbol on the FCR page. The ID is displayed until the FCR track is no longer valid or a different target is assigned to the same team member.

Received messages are extrapolated and displayed on the HSD for 8 seconds. During this period, the data link ignores any A-A Request command (COMM switch left >0.5 sec).

The following applies to assignment operation for receiving aircraft. Reception of an assignment message is independent of data link mode. The following process describes the reception of an assignment message:

1. Upon reception (indicated by the tone in the headset), verify display of "ASSIGN" in the upper middle part of the HUD. The ASSIGN cue is displayed for 8 seconds or until depression of WARN RESET on the ICP.
2. Verify VMU (a.k.a., Bitchin' Betty) message "DATA" in the headset if ownship was the assignee.
3. Verify display of data link assignment symbol on the FCR and HSD pages.

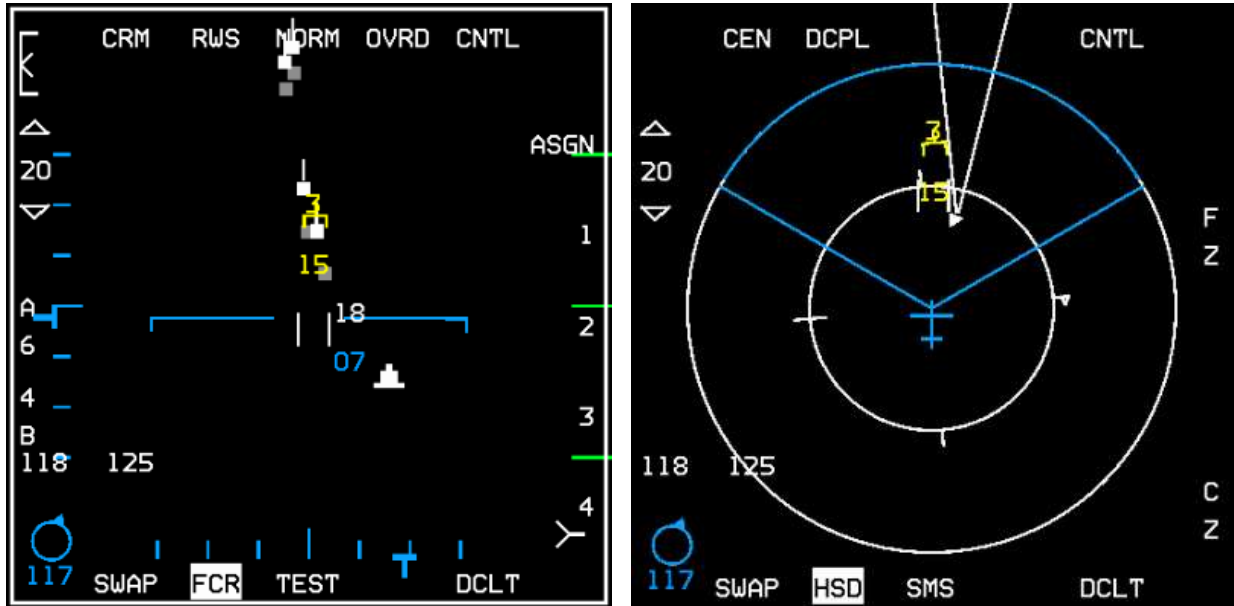

Figure 49 Assignee (#3's) FCR, HSD and HUD

Data link assignment target positions are extrapolated and displayed for 8 seconds similar to other A-A data link symbology. The data link system will maintain 4 different slots for reception of assignment messages of the 4 team members. For example, if the flight lead assigns targets one after another (including one to himself), it is possible for team members' displays to contain 4 different assignment symbols (with different ID's) indicating the assigned targets of each team member.

During the 2 seconds that XMT is displayed, another FCR target can be selected as the TOI; however another assignment cannot be made until XMT is removed. The data link system also allows an assignment to be made to oneself by depressing and releasing the OSB adjacent to ownship member number. This message is transmitted to all teammates similar to other assignments.

Although a data link assignment message is broadcast to all members of the intraflight team (up to 4 members currently – in the future this may expand to 8), assignments can only be made to members whose addresses are entered in the left 4 slots (#1, #2, #3, #4); hence, assignment ID's 1-4 on the A-A FCR page.

1.5.5.1.2 Continuous Mode Operation

The Continuous (CONT) mode allows the pilot to request continuous update of request and reply intraflight messages. This is the mode that also requires coordination amongst flight members if you are flying in the multiplayer environment, as only one aircraft needs to be in CONT mode and initiates the CONT data link round.

All messages are broadcast to the intraflight team. The CONT loop starts when a team member (most likely the flight lead) transmits an A-A Request while in the CONT mode. The CONT label is highlighted to show the aircraft is the controller of the CONT round. The request message from the network controller is followed by the replies of team members and a time delay. The sequence of the team member replies are dependent on the sequence of replies requested by the controller.

The aircraft automatically selects the reply sequence and it is not pilot changeable. This time delay (CONT mode delay), allows a time window for transmissions of other non-A-A messages. After the delay period has expired, the controller aircraft automatically resends the request message. The CONT loop ends when the pilot of the controller aircraft deselects the CONT mode.

Received data link A-A Request and Reply messages are displayed on the HSD and FCR the same as DMD and ASGN modes. Assignments of air targets can also be done in the CONT mode similar to DMD and ASGN modes using the “1, 2, 3, 4” labels next to OSBs 7-10.

1.5.5.1.3 System Master Mode versus A-A Intraflight Data Link

The ability to initiate an A-A Intraflight data link loop and to automatically reply is independent of system master mode and data link mode. When A-A data link has been selected for display using the HSD Control page, all valid A-A data link symbols are displayed on the HSD (when within the HSD FOV) independent of system master mode and data link mode.

This is consistent with the god's eye situation awareness philosophy for the HSD. The radar page displays A-A data link symbols only when the radar mode is one of the A-A modes.

1.5.5.1.4 FCR Declutter

The A-A FCR scope may be decluttered of IDM symbology by a Comms switch left <0.5 secs. The display will remain decluttered until Comms switch left <0.5 secs is toggled again.

1.5.6 Air-To-Ground Intraflight Data Link

The A-G intraflight data link function allows the transmission of data associated with the currently selected steerpoint or the A-G radar cursor position, which can then be used by flight members to move their sensors (A-G radar cursors, TGP, etc.) onto a target or point of interest.

1.5.6.1 Air-to-Ground Data Link Steerpoint

A-G steerpoint data link is accomplished hands-on using the HSD as SOI. The HSD can be selected as the SOI using the DMS (Display Management Switch) down position, upon which the MFD SOI (Sensor of Interest) box (around the MFD perimeter) is placed on the HSD.

Hands-on selection of the steerpoint location is done by placing the HSD cursor on the desired steerpoint and designating with TMS Up. Transmission of the A-G data link message is accomplished by depressing the Comms switch right while the HSD is SOI and also triggers an audible tone in the headset. A highlighted XMT will also be displayed adjacent to OSB 6 on the HSD base page. Alternatively, the pilot may select the steerpoint he wants to data link via the UFC (Up-Front Controls – ICP), switch the SOI to the HSD and then depress Comms switch right. Data link steerpoints show up as a large X symbol on the HSD and are stored in steerpoints 71-80, which allows multiple DL steerpoints to be retained by the navigation system. Once they are all filled up, #71 will be overwritten and subsequent DL STPTs will overwrite the other numbers.

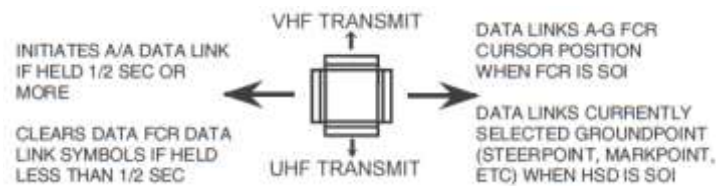

Figure 50 Data link Switch Summary

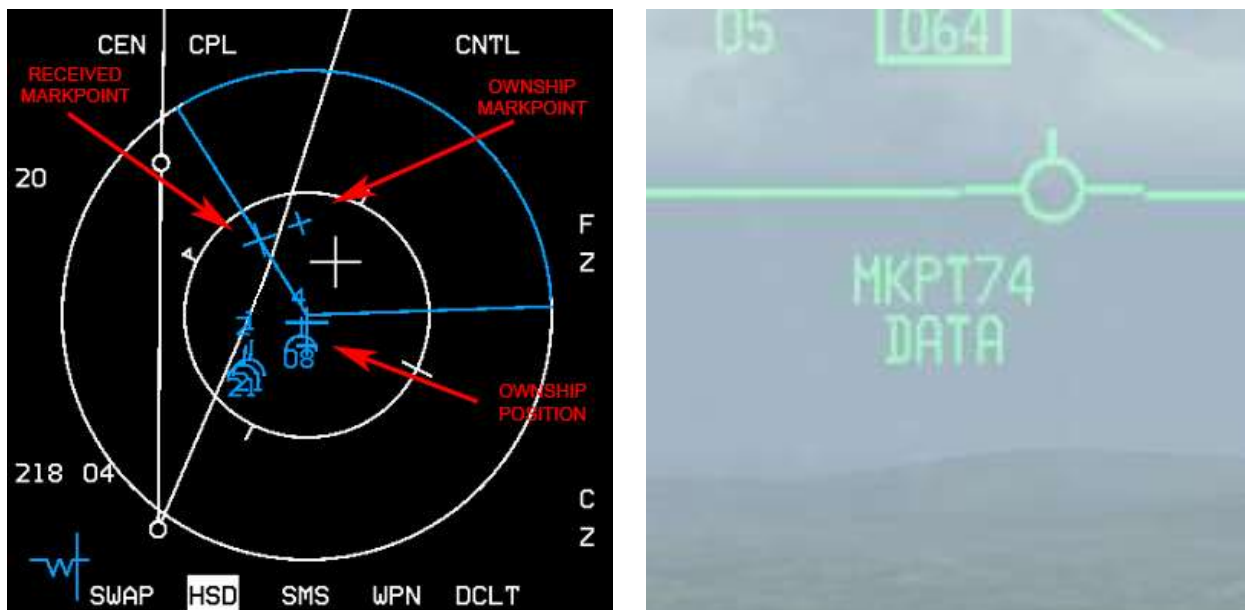

Figure 51 Assignee (#3's) HSD and HUD showing data linked Markpoint

1.5.6.1.1 Operational Considerations for A-G Data Link Transmit Address

The transmit address may be changed before transmitting a STPT or A-G cursor position (A-G cursor position is described below). The system default is your flight's broadcast address (a number ending in "0", i.e., 20 if you are the second flight in a package). Transmitting to this broadcast address will send the data to individual groups or teams with the same first digit in their ownship address: e.g., transmit address 20 will transmit to addresses 21-24.

If, for example, the flight leader of four F-16s wants to data link a markpoint to all members of his flight and their addresses are 21 through 24, he would enter a transmit address of 20 in the XMT field and initiate data link transmission with SimCommsSwitchRight (Page Down). The data linked markpoint would be displayed on the HSDs of all flight members in the intraflight link. Likewise, if his 4-ship is a part of a package of 8 aircraft and the other flight's broadcast address was 10, he could enter 10 and transmit A-G data to the other flight of four.

A transmit address not ending in zero is directed to a single respective aircraft. For example, if a pilot wanted to send a mark point to only his #3 wingman, and the wingman's team address is 23, the pilot would have to enter 23 (the wingman's address) in the transmit address field on the A-G DL page (Figure 46). When the pilot transmits the message, only wingman #3 will have the markpoint displayed on his HSD.

Entering in a specific transmit address is only for A-G operations and does not affect the A-A intraflight data link. Transmission of data to a single aircraft can be done to a member outside of your immediate 4-ship team. In other words, if you were address 21 and there was a flight of 4 with addresses 11-14 and you wanted to transmit a mark point to only the leader of that flight, you would enter 11 as the transmit address and initiate the data link transmission as above.

1.5.6.2 **Air-to-Ground Data Link Cursor Position**

The A-G cursor function provides hands-on transmission of A-G FCR cursor position. This function is independent of system master mode or data link mode while the FCR is in ground map (GM), ground moving target (GMT), or SEA modes and requires the FCR to be the sensor of interest (SOI) for transmission.

Transmitting ownship A-G cursor coordinates is accomplished hands-on by making the FCR the SOI, slewing the radar cursor with the CURSOR/ENABLE control to the point-of-interest and then depressing Comms switch right on the throttle (Page Down). An audio tone is audible in the headset and the mnemonic XMT is highlighted for two seconds adjacent to OSB 6 on the HSD. The pilot will not see his own A-G cursor position data link symbol, which is a yellow asterisk (*) symbol (Figure 52).

Reception of A-G cursor data link message is independent of the current data link mode. Several cues are provided by the avionics system to indicate reception of a data link message. An audio tone is activated followed by the aural VMU message "DATA" in the headset and the HUD message, "CURSOR" and "DATA" in the middle of HUD. This HUD message remains until the DRIFT C/O switch is positioned to WARN RESET on the ICP or the data is no longer valid (i.e. 13 seconds has elapsed since cursor reception). After reception of an A-G cursor message, the HSD and/or FCR (if it is in one of the three ground-map modes – GM, GMT, SEA) displays the data linked A-G cursor symbol (*).

However, this symbol is blanked on the FCR if FZ is selected, or the radar is in FTT (fixed target track). The symbol is displayed with an ID (1-4) which represents the message source (team member 1-4), or displayed as a 2-digit number representing the IDM address of another member of the 8-ship team if not from team member 1-4.

This symbol remains on screen for a total of 13 seconds and begins flashing during the last 5 seconds if it is within display FOV. If ground datalink has been decluttered (via OSB 17) on the HSD control page, no A-G cursor symbol will be displayed on the HSD.

The system stores and displays a maximum of 3 different data linked cursor positions simultaneously; subsequent receptions overwrite existing locations in a rotary fashion. The data linked cursor position is not stored as a steerpoint.

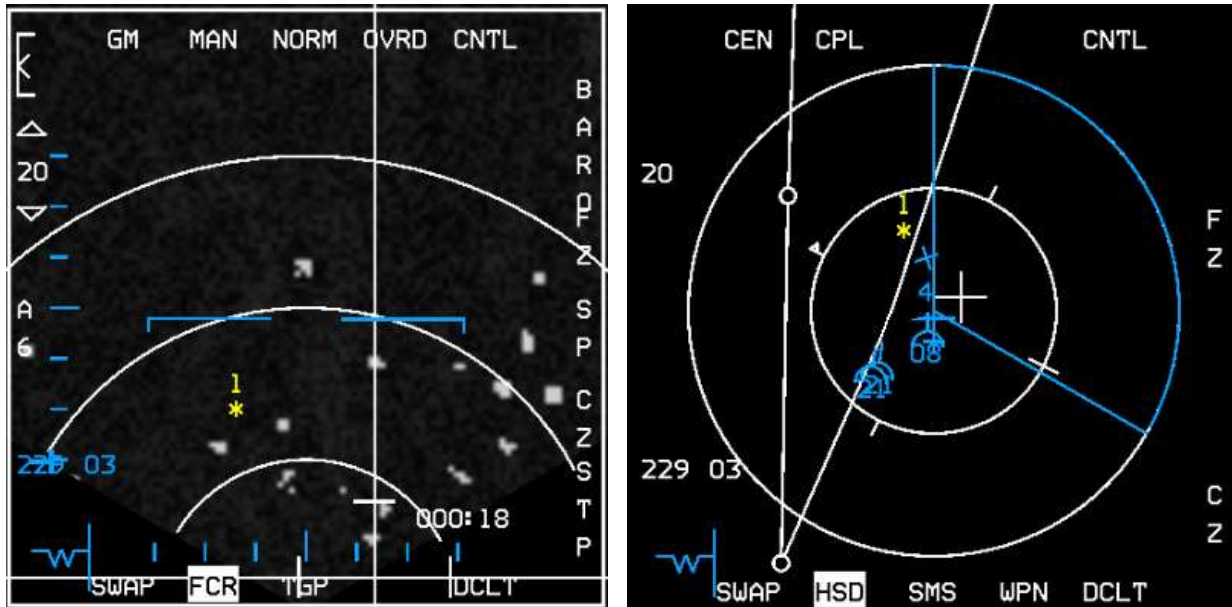

Figure 52 Assignee (#3's) FCR, HSD and HUD. Assigner (#1) sent cursor data NNE of ownship Markpoint

“Datalink Ground Target” is a wingman/element command that will request the AI to datalink his A-G FCR cursor position of his target of interest as described above. Note that this command only works if you are either a flight lead or an element lead (#3) and have an AI wingman under your command.

1.5.7 IDM Use Scenarios

With the above knowledge you are ready to learn some basics in using the IDM in the tactical environment. We will discuss A-A operations and A-G operations.

1.5.7.1 *Air-to-Air*

You are the flight lead of a 4-ship of human wingmen in a multiplayer OCA mission. Your role is to conduct a sweep to clear the airspace of enemy fighters before the strikers behind you bomb their target. Armed with AIM-120s, AIM-9s and your trusty IDM, you're ready to deal with any enemy groups that come your way.

After getting safely airborne, your wingman, element lead and his wingman gain visual and join up in fluid 4. You briefed your flight that you as flight lead would be the IDM controller for Continuous mode. You initiated the IDM "round" with "Comms switch left >.5 secs" right after takeoff and have been receiving data link rounds from your flight ever since.

After fencing in and getting ready for combat, your formation picks up two groups split in azimuth 10 miles apart – it looks like both groups are 2-ships. They are hot and have moved into factor range and you decide to commit on them. Knowing that you can assign targets in CONT mode (even without the wingman labels showing on the FCR), you bug the eastern group lead contact and hit OSB 9 on the FCR to transmit an assignment for #3 to target that group followed by a radio call to your #3: "Viper13, target group bullseye 090/20, twenty thousand, data". Number 3 responds: "3!" then does almost the same steps as you did and targets his wingman, #4, onto the second contact in his group.

Next you slew your radar cursors to the group you intend to target, bug the second contact in that formation and hit OSB 8 followed by a radio call to your wingman: "Viper12, sort group bullseye 090/10, twenty thousand, data". Number two sees the IDM assignment and quickly calls: "2, sorted". Lastly you lock up the lead contact in your group and hit OSB 7 to send an assignment to your flight indicating your targeting assignment. Since you're in CONT mode, from here on out, your flight member's bugged targets continue updating on the HSD and FCR every 8 seconds, along with their ownship positions, ensuring everyone has situational awareness on both groups and each other. Soon, AIM-120s are screaming to their targets – it's a quick kill on all four.

1.5.7.2 *Air-to-Ground*

In today's tasking, you've been assigned to hit a column of T-62 tanks that are on their way towards the border, intent on attacking friendlies. You're the flight lead of a 2-ship of BLK 40 F-16s. You're armed with 2 x CBU-87, 2 x GBU-12 and a targeting pod. Prior to taking off, you brief to your wingman that you will be the IDM net controller and will be using CONT mode.

After takeoff your wingman checks his IDM mode is set to ASGN and then moves his Comms switch left for >.5 secs to request a one-off situational awareness update from the flight. He uses 5 Nm scope in RWS, sees your IDM team member symbol next to his radar contact and begins a quick rejoin.

After fence in you Comms switch left for >.5 secs and begin initiating a continuous loop. You're getting close to where the tanks are expected to be now, so you begin searching in GMT for the column. You pick up a line of movers 5 Nm north of your steerpoint. You switch to SP mode, TMS forward and slew up to the movers. You Comms switch right with the radar as SOI and send your GMT radar cursor position to your wingmen. Bitchin' Betty gets his attention

aurally in addition to the visual message in the HUD. He's got your GM cursor symbol (*) on both his HSD and FCR and slews to that position.

Next, you decide to create a markpoint at the location of the column. You hit MARK 7 on the ICP, SEQ Right to select FCR and then TMS Up; you've got a markpoint. Mode-selecting it with the M-SEL 0 button makes it the active steerpoint. You hit CZ to zero out your cursor slews, then switch SOI to the HSD and Comms switch right again.

This time it sends a datalink steerpoint to your wingman, which is a more permanent means for him to maintain SA on the position of the column. He then switches to STPT 71, so you're both referencing the same steerpoint. After positive ID of the column, you and your wingman begin a high wheel attack on the column and lay down some serious punishment.

With the background text and two examples, you should have a good working idea of the capabilities of IDM and how useful it can be in the tactical environment. Practice and experimentation will lead to understanding and developing proficiency with this valuable tool.

1.5.8 IDM Operational Considerations

There are a few last considerations you need to know about the IDM system in Falcon. During mission planning/mission building, when you are building a package of aircraft, the first flight (in this case a 4-ship) in a package will be assigned addresses 11-14. The next flight will be 21-24 and so on. If during planning you adjust takeoff times so that, for example, the first flight you created takes off later than another flight in the package, the first flight you created will *still* use addresses 11-14. This is important because your IDM addresses may be different than what you thought they were going to be if you were not familiar with the order in which the flights within the package were created.

A good technique is to check the order of the flights in your package on the Briefing page in UI before you commit to 3D; it will list them in order. This can help you select the right transmit addresses for other flight in your package (if there are several flights in the package and you want to monitor the location of any of those flights).

Another consideration is the flexibility of the IDM. For example, you are 2-ship of DCA and the first flight of a package that has 4 flights in total. You are addresses 11-12; already in the left column. You decide that you want to maintain situational awareness primarily on the flight leads of the other flights. You can enter 21, 31, and 41 in the IDM and receive their positions on the HSD, or you can enter 2 of those addresses in the left column and also receive information on any radar contacts they lock up if you are in IDM CONT or use Comms switch left to get an update.

The last consideration involves contingency planning. Normally the flight lead would be the net IDM controller of a flight. If he is shot down, another flight member (normally #3) will have to take over and set CONT mode and reinitiate the DL rounds.

1.6 RADAR WARNING RECEIVERS

The Radar Warning Receiver consists of several antennas, a processing unit, a radar library and a display. It allows the aircraft to detect and identify radio emissions of radar systems reaching the aircraft and is a vital tool in both A-A and A-G operations for identifying, avoiding, evading or engaging threats.

Previous versions of Falcon had a RWR which was unrealistically accurate in identifying emissions and their direction and distance from the aircraft. Additionally, the various RWRs equipping all F-16 variants were modelled on a single RWR, the ALR-56 equipping USAF F-16s. This version features the majority of RWRs present in most variants, each having custom modes of operation, displays, sounds, controls and direction-finding accuracy. In addition, the distance of the emitter symbol from the centre of the scope will not always be proportional to the actual distance, some ambiguities have been introduced.

1.6.1 General information and default modes of operation

This section describes in-depth the default modes of operation of the RWR, primarily based on the ALR-56M. Specific RWR models and their idiosyncrasies are described starting from section 1.5.2.

1.6.1.1 *HANDOFF* Modes

How long the HANDOFF button is pressed determines what operating mode the RWR is in. The following describes the button operation:

Short push = less than 1.0 second.

Long push = more than 1.0 second.

Note: Short push and long push are general RWR "control" terms and apply to using both a keystroke as well as using the mouse to click the 3d cockpit. However, using these controls vary a little bit when using a keystroke versus the mouse.

There are 4 operational modes of the RWR. They are: normal, diamond float, transient and latch modes.

1.6.1.1.1 Normal

Using the HANDOFF button controls how each of these modes are entered and controls the function of the diamond symbol on the display. In normal, the diamond symbol is inhibited and threat audio is limited to "new guy" (or new threat) alert and missile launch audio. New guy audio is 3 bursts of sound in 1.5 seconds of that emitter. New guy alert is also seen visually by symbols alternating between normal size and 1.5 times normal size for the first 4 seconds of display. Normal mode will yield a fairly quiet RWR.

1.6.1.1.2 Diamond Float

Diamond float mode is entered via a short push of the HANDOFF button. In this mode the diamond symbol on the HANDOFF button illuminates and the diamond on the display floats to the highest priority symbol. Sound for that emitter is heard continuously. Another short push of the HANDOFF button will deselect this mode and go back into normal mode. This mode is recommended for maximum SA.

1.6.1.1.3 Transient

Transient mode is entered by pressing and holding the HANDOFF button. In this mode the diamond symbol steps from the highest priority symbol to the next highest in descending priority order. The diamond will continue stepping for as long as the HANDOFF button is held and audio is played as the diamond enhances the symbol. Releasing the button changes the mode to latched.

1.6.1.1.4 Latch

In latched mode the diamond symbol remains on the last symbol it was on when the HANDOFF button is released. Sound for that emitter is heard continuously. If the symbol times out (emitter no longer detected), the RWR will go back to diamond float mode.

1.6.1.2 **Using HANDOFF**

The HANDOFF button may be actuated with a keystroke or with the cockpit art. For simplicity, it is recommended that pilots map a keystroke to the keyboard or HOTAS, as the short and long pushes are modelled correctly as stated above. In the 3d cockpit, clicking the mouse works as follows:

Left-click = short push.

Right-click = long push; then to “release” a long push, either left or right click.

1.6.1.3 **Noise Bars and Cycle Timer**

The RWR scope also consists of four noise bars located around the centre circle at 6, 9, 12 and 3 o'clock. They indicate the status of noise in the bands 0, 1, 2, and 3 respectively; however this is not implemented and is graphical only. There is a cycle timer on the left end of the band 3 noise bar. This is a vertical bar that moves up and down. As the RWR becomes saturated with signal activity the cycle timer moves progressively slower. With no signal activity, it moves up and down in 1 second. With full RWR activity, it moves up and down at a rate of 2.6 seconds.

1.6.1.4 **RWR Control Head Buttons**

This section describes the function of the buttons and the illumination pattern of the associated legends for the THREAT PRIME and THREAT AUX control heads that are used to manage the RWR in the F-16.

All lamping should show green legends when illuminated and dark when not illuminated unless otherwise noted.

All button legends are white and visible when power is both on and off.

Table 5 ALR-56M Buttons and Indicators

BUTTON LEGEND	LAMP	LAMP OPERATION DESCRIPTION	BUTTON PRESS FUNCTION
HANDOFF	diamond	On only when a HANDOFF mode is engaged (FLOAT, TRANSIENT or LATCH). Off otherwise.	See description of HANDOFF function above.
	H	On full time but only when power is present to the RWR.	
MODE	PRI	On provided there is power to the RWR and the PRIORITY mode is engaged. Mutually exclusive with the OPEN lamp. This lamp will also flash at 4Hz in PRIORITY mode and the RWR is tracking more than 5 radar sources painting ownship.	Press to toggle between OPEN and PRIORITY mode. OPEN mode shows up to 12 tracks normally or 16 when UNKNOWN mode is engaged. PRIORITY mode shows only the most lethal 5 tracks that the RWR currently tracks.
	OPEN	On provided there is power to the RWR and the PRIORITY mode is NOT engaged. Mutually exclusive with the PRI lamp.	
LAUNCH	MISSILE	Red. On provided there is power to the RWR and if a radar missile is being guided on ownship. Flashes at a 4Hz rate when "on".	No button function implemented.
	LAUNCH	Red. On provided there is power to the RWR and if a radar missile is being guided on ownship. Flashes at a 4Hz rate when "on".	
T	TGT SET	On provided there is power to the RWR and the target separate function has been selected by the player.	Pressing this button will spread out the currently displayed emitter symbols for 5 seconds whereupon it returns to normal display without further player action.
	TGT SEP	On full time but only when power is present to the RWR.	
SYS TEST	ON	On when selected. Self-test shows two test screens.	Initiates self-test. Can be used to 'reset' the RWR if you get the 'stuck RWR bug'.
	SYS TEST	On full time but only when power is present to the RWR.	
ship symbol	U	Can only be on if there is power present to the RWR and one of the following conditions is true: a) UNKNOWN mode has been selected by the player (lamp on full time in this case); or b) UNKNOWN mode is not engaged but the RWR detects unknown type radars painting ownship (U flashes at 4Hz rate).	Press to toggle between UNKNOWN mode on and off. When unknown mode is on, the display will show up to 16 emitter symbols including any that are in the list of unknown type.
	UNKNOWN	On if there is power to the RWR and UNKNOWN mode has been selected on by the player.	
SEARCH	S	Can only be on if there is power present to the RWR and one of the following conditions is true: a) SEARCH mode has been selected by the player (lamp on full time in this case); or b) SEARCH mode is not engaged but the RWR detects search mode radars painting ownship (S flashes at 4Hz rate).	Press to toggle between SEARCH mode on and off. When search mode is on, the display will show S symbols for emitters that are detected as being in an air search radar mode.
ACT/PWR	ACTIVITY	On when there is power to the RWR and the RWR detects missile activity (guide or tracking modes).	No button function implemented.
	POWER	On full time but only when power is present to the RWR.	
ALTITUDE	LOW	On when there is power to the RWR and the player has selected LOW altitude threat preferences.	Press to toggle between LOW and HIGH altitude threat assessment biasing. SAM dat files assign relative threat for a given SAM radar's base lethality score for both LOW and HIGH cases which the RWR uses in assessing relative threat in real time.
	ALT	On full time but only when power is present to the RWR.	
POWER	SYSTEM	On full time but only when power is present to the RWR.	Press to toggle between RWR power on and off.
	POWER	On full time but only when power is present to the RWR.	

1.6.2 BAE Systems (Loral) AN/ALR-56M

C/D band (0.5-2 GHz) and E through J band (2 to 20 GHz)

Direction-finding accuracy: 15 degrees (E through J band); omnidirectional (C/D band)

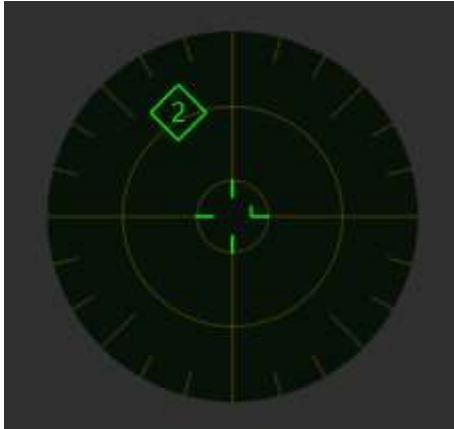

1.6.2.1 Operations

After boot up I indication is in middle of scope, after while it changes to WO indication in middle of scope. After initial BIT finishes indications disappear.

System runs periodical self-tests in background. Pilot can initiate manual Self-Test.

POWER Button	Power ups system
ALTITUDE Button	Selects low alt threat threat table, L indication in middle of scope
SEARCH Button	Shows search (S symbol) radars, S indication in middle of scope
ACT/PWR Lights	Indicates system power and activity on scope
TGT SEP Button	Separates overlapping contacts on scope
SYS TEST Button	Initiates self-test
UNKNOWN Button	Shows unknown contacts, U symbol flashes when there is filtered out unknown contacts
MODE Button	Selects priority mode
LAUNCH Button	Indicates launch, initiates launch light test when pressed
HANDOFF Button	Select highest priority target for composite audio, held for selection browsing

1.6.2.2 *Self-Test*

Self-test shows two test screens.



After that if any fault is detected shows faults list screen and reverts to normal display with F in middle indicating fault.



1.6.2.3 *Buttons and Light Mapping*

Mappings are not changed from default ones.

1.6.3 Raytheon (Litton) AN/ALR-69(V)

C/D band (0.5-2 GHz) and E through J band (2 to 20 GHz)

Direction-finding accuracy: 15 degrees (E through J band); omnidirectional (C/D band)

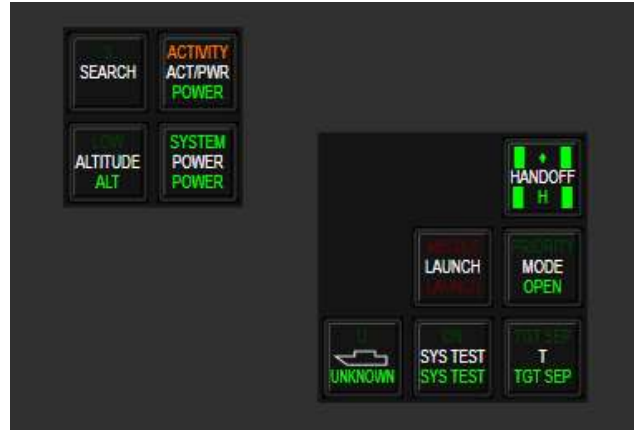
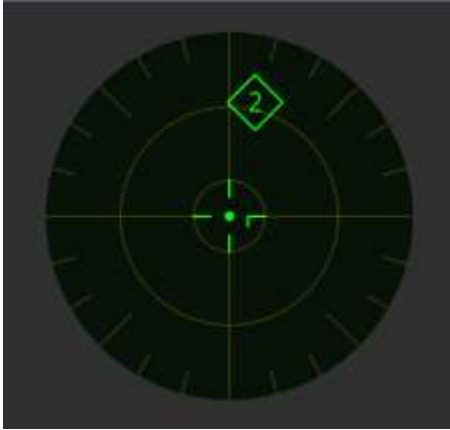

1.6.3.1 Operations

After boot up test pattern is on scope, after while F appears in middle of scope for a moment. After initial BIT finishes indications disappear.

System runs periodical self-tests in background. Pilot can initiate manual Self-Test.

POWER Button	Power ups system
ALTITUDE Button	Selects low alt threat table, L indication in middle of scope
SEARCH Button	Shows search (S symbol) radars, S indication in middle of scope
ACT/PWR Lights	Indicates system power and activity on scope
TGT SEP Button	Separates overlapping contacts on scope
SYS TEST Button	Initiates self-test, if pressed and within 0.5 sec UNKNOWN button is pressed then it toggles naval mode
UNKNOWN Button	Shows unknown contacts, U symbol flashes when there is filtered out unknown contacts
MODE Button	Selects priority mode
LAUNCH Button	Indicates launch, initiates launch light test when pressed
HANDOFF Button	Select highest priority target for composite audio, held for selection browsing

1.6.3.2 *Naval mode indication*



1.6.3.3 *Self-Test*

Self-test shows two test screens. If any fault is detected it will be indicated on second test screen with flashing BAD text. Scope reverts to normal display with F in middle indicating fault.



1.6.3.4 *Buttons and Light Mapping*

Mappings are not changed from default ones.

1.6.4 Raytheon (Litton) AN/ALR-93(V)1

C/D-band (0.5-2 GHz) and E through J band (2-20 GHz)

Direction-finding accuracy: 15 degrees (E through J band); omnidirectional (C/D band)

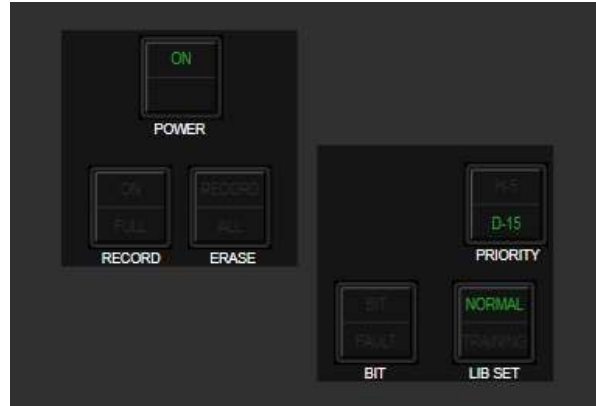
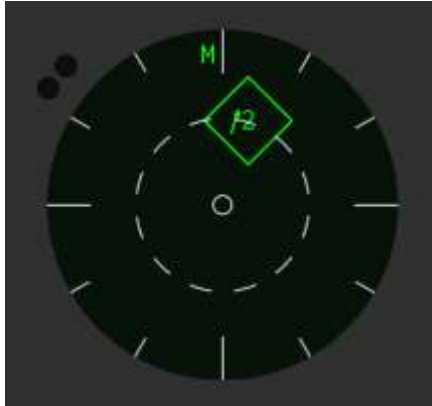

1.6.4.1 Operations

System runs periodical self-tests in background. Pilot can initiate manual Self-Test.

On the top of scope are indications of CMDS mode and ECM state. On the bottom is possible ECM interference indications (repeated on FCR/TFR MFD and HUD). On the right side is ECM unavailable indications.

POWER Button	Power ups system
BIT Button	Initiates self-test, if fault detected FAULT light will be on
LIB SET Button	Toggles normal and training libraries, normal one doesn't contain search radars
PRIORITY Button	Selects priority mode

1.6.4.2 Symbols

	Highest priority
	Lethal threat
	Launch
	SAM
	Airplane
	Search radar
	Unknown emitter
	AAA

1.6.4.3 Symbol Codes

For AAA, SEARCH, UNKNOWN, CW Emitters

PRI value (ms)	Symbol (first character of unknown emitter symbol)
200	0
201 - 300	1
301 - 400	2
401 - 500	3
501 - 700	4
701 - 900	5
901 - 1200	6
1201 - 1500	7
1501 - 2000	8
2001 - 10000	9

Band	Symbol
E	1
F	1
G	2
H	2
I	3
J	4
anything else	1

T means track-mode and is displayed after single-character emitters, e.g. 6T, for radars that are in track-mode.

A 2 character limit means T cannot be displayed next to emitters that already have 2 characters, so to differentiate the radar mode: octagon + beep every 7 seconds = lock (STT); if you do not hear a beep = track (SAM/TWS or similar).

1.6.4.4 Buttons and Light Mapping

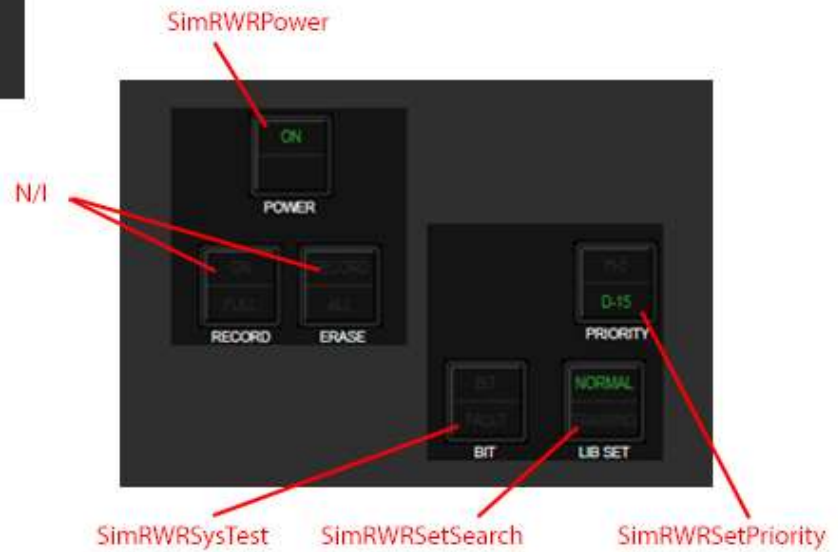

1.6.5 Thales Airborne Systems Carapace

C through K band (0.5 to 40 GHz)

Direction-finding accuracy: 1 degree (C through K band);

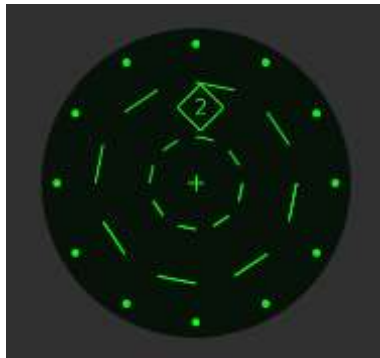

1.6.5.1 Operations

System runs periodical self-tests in background. Pilot can initiate manual Self-Test.

After power up, female voice informs about faults. Same voice is present on manual Self-Test. Small FAIL light indicates fault as well. This can be cleared only by power off/on cycle.

FAIL Light	Indicates fault
EXP Button	Separates overlapping contacts on scope, double click within 1ses initiates self-test indicated by BIT light
PRIO Button	Selects priority mode
MODE Button	Toggles libraries, when AI indicator is on search radars are included
EDS AUTO Light	Indicates CMDS AUTO MODE
MAN ON Light	Indicates CMDS MANUAL MODE
PWR Button	Power ups system

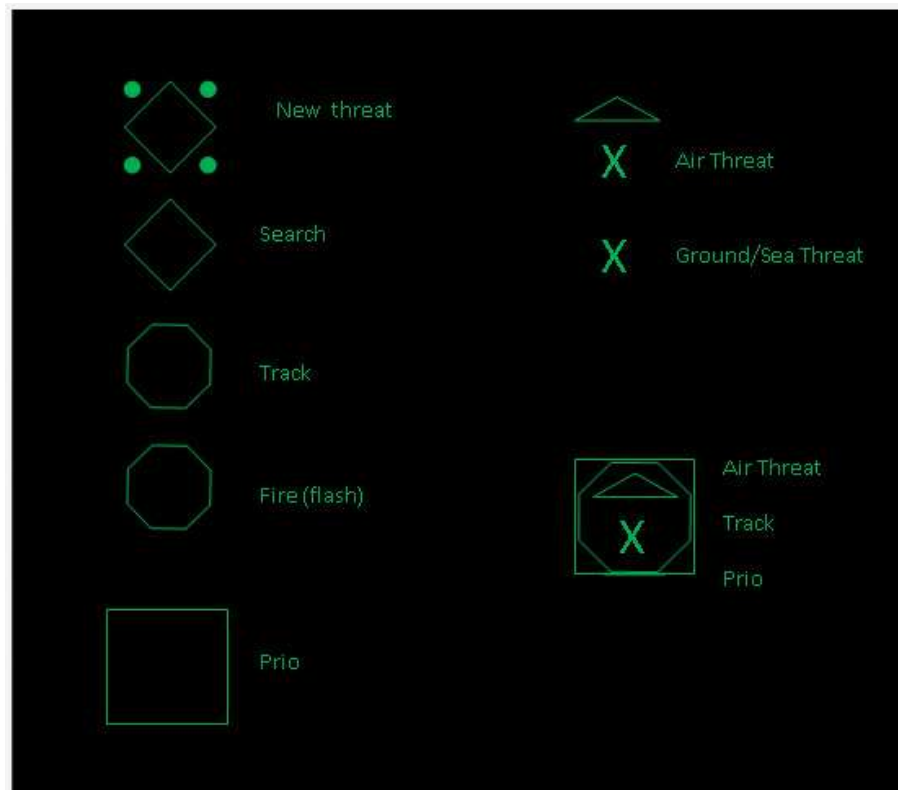
1.6.5.2 *Symbols*

1.6.5.3 *Buttons and Light Mapping*



1.6.6 Raytheon (Litton) AN/ALR-67(V)3

E through K band (2 to 40 GHz)

Direction-finding accuracy: 15 degrees (E through K band); omnidirectional (C/D band)

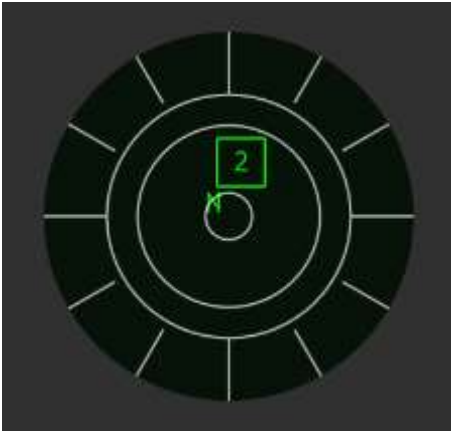

1.6.6.1 Operations

System runs periodical self-tests in background. Pilot can initiate manual Self-Test.

ENABLE OFFSET Button	Select highest priority target for composite audio, held for selection browsing
ENABLE SPECIAL Button	Separates overlapping contacts on scope
LIMIT DISPLAY Button	Selects priority mode
POWER Button	Power ups system

1.6.6.2 Buttons and Light Mapping



1.6.7 Elisra SPS-1000V-5

Bands 0.5 - 18 GHz (band C to J)

Direction-finding accuracy: 15 degrees (C through J band)

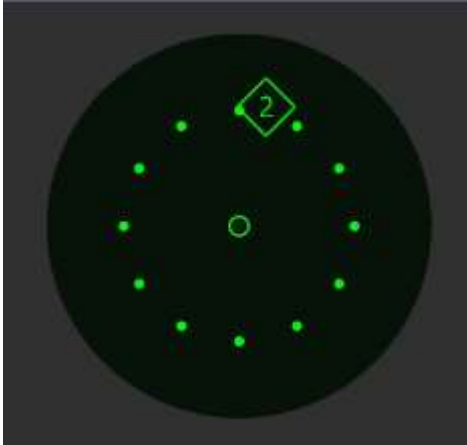

1.6.7.1 Operations

Exactly same as ALR-69 minus test mode display

1.6.7.2 Buttons and Light Mapping

Mappings are not changed from default ones.

1.7 ALE-47 COUNTERMEASURES DISPENSER SET

The ALE-47 Countermeasures Dispenser Set (CMS switch and controls) and electronic warfare system (EWS) was rewritten for 4.32 but some key callbacks are different in 4.34. For further information on these please refer to the BMS-Manual and/or other detailed manuals in the \Docs\01 Input Devices folder.

There are 6 chaff/flare programs: programs 1-4, selected on the CMDS control panel, activated in MAN mode with CMS up, or in SEMI / AUTO modes with CMS down, manual program 5 activated via the cockpit slap switch and manual program 6 activated with CMS left.

To program your HOTAS to operate realistically, the switch layout is as follows:

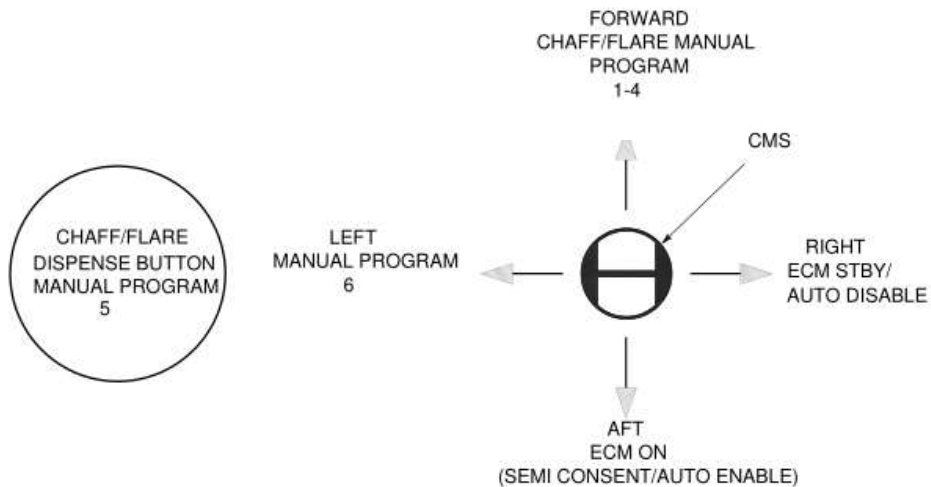

Figure 53 CMS Switch



Figure 54 CMDS Cockpit Control Unit (CCU)

1.7.1 CMDS Modes

In **AUTO** (automatic), consent once given with CMS down is assumed until it is explicitly cancelled with a CMS right.

In **SEMI** (semi-automatic), consent allows the CMDS to run the program once only. If the system determines that the threat persists after that (or another has appeared) then it will prompt you for consent again with the "COUNTER" VMU message.

Note that for SEMI and AUTO, the consent state is tracked even if the CMDS is not yet in SEMI/AUTO, so if you have previously done a CMS down (consent) and then you switch the mode to AUTO with a threat detected, the CMDS will start dispensing right away based on that previous consent. It is recommended that you inhibit release prior to entering SEMI or AUTO so you won't inadvertently spew countermeasures. If the CMDS thinks it should be dispensing in SEMI or AUTO and you haven't yet consented, it will always prompt you with "COUNTER".

The way SEMI and AUTO modes work now is somewhat analogous to the difference between semi-automatic and automatic weapons. For AUTO, once you have given consent, the CMDS unit will keep on dispensing, i.e. rerunning the program over and over until the threat is no longer detected. In SEMI the CMDS unit will not dispense until you hit consent and then it will run one program. If a threat is still being detected after that program is complete in SEMI, the "COUNTER" VMU message will play again to prompt you for additional consent.

The **MAN** (manual) position of the MODE knob gives the pilot finer control of countermeasure expenditure as each press of CMS up will result in the relevant program (1-4) being executed once only.

The **BYP** (bypass) position of the MODE knob will result in exactly one chaff and one flare for any dispense request that you command manually (there is no auto or semi-auto dispense in BYP). This may be useful when you hit the BINGO values for chaff and/or flares and want to be really careful with how many consumables you dump overboard, without having to reprogram any of the programs in flight via the UFC.

STBY (standby) mode is used to inhibit chaff/flare release while making changes to any of the CMDS programs in the UFC. It is the only mode in which changes to the programs can be made.

1.7.2 CMDS Programs

With the MODE knob in MAN (manual), SEMI or AUTO, the CMS up (run program) command will manually activate the program currently selected via the PRGM knob (i.e. 1-4). Note that this manual activation will override any automated-initiation dispense program that may be running (if any). Programs 1-4 are also run when consent is given and a threat (i.e. missile launch detected) is present –one round for SEMI, continuous for AUTO. If you are in AUTO and there is a threat and a program is running and then you mash CMS up, the manual program will run immediately (i.e. the program that the AUTO was running is stopped and a fresh run is started – it's the same one because CMS up activates the same program(s) that SEMI/AUTO use). If after running the manually commanded program run the threat is still being detected, AUTO will once again commence running programs for you.

There are two other programs that you can run at any time. Program 6 is always activated with CMS left. Program 5 is always activated by the slap switch ('S' key by default - in the real jet this is a big button on the cockpit wall just outboard of and above the throttle grip).

You therefore have one-touch control over manual activation of three separate programs, without changing the knob(s) on the CMDS panel. For example a pilot could set their system up so that programs 1-4 are different chaff programs for countering specific radar threats, while 6 is a flare only program for close range A-A engagements or low level MANPAD defence and 5 is a chaff/flare combo, designed to react quickly to unexpected or unknown threats.

1.7.3 EWS DED Upfront Controls

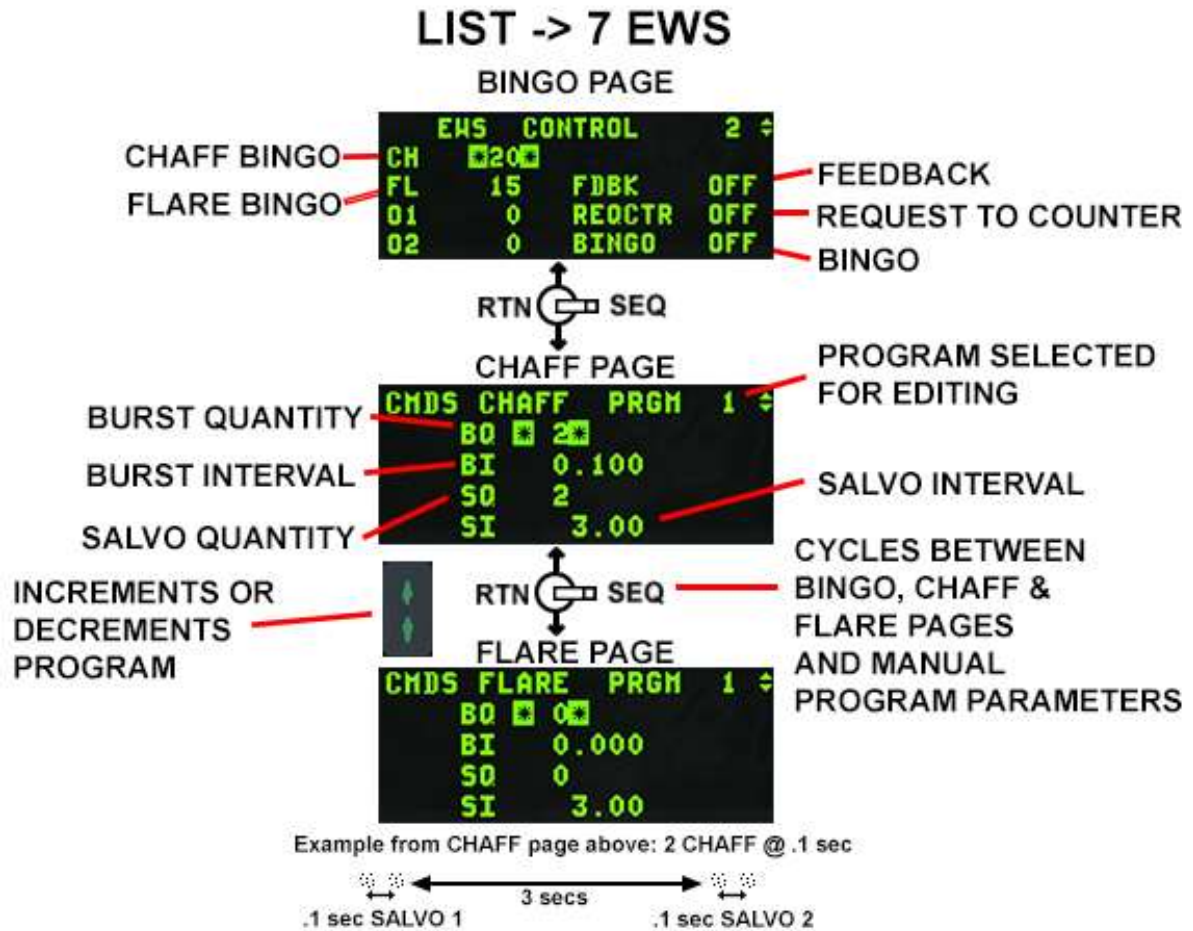

Figure 55 DED EWS Pages

The CMDS DED upfront controls are located on the EWS BINGO page (ICP LIST 7) and CMDS CHAFF and FLARE PGM pages as shown in Figure 55. Bingo quantities for expendables are DTC loadable and can be changed via the UFC only if the CMDS CCU mode knob is in STBY.

The REQCTR (request to counter) option enables/disables the “COUNTER” VMU message used to indicate that the EWS has determined that expendables should be dispensed and manual consent is requested.

The BINGO option enables both the “LOW” VMU message used to indicate that an expendable has reached the bingo quantity and the “OUT” VMU message used to indicate that an expendable is depleted. Bingo quantity can be set to any value between 0 and 99.

The FDBK (feedback) option enables/disables the “CHAFF FLARE” VMU message, used to indicate that an expendable program has been initiated.

The CMDS PGMs can be changed when the CMDS CCU mode knob is in STBY. Positioning the DCS to SEQ selects the expendable category (CHAFF first then another SEQ for FLARE) for the countermeasures program number shown in the upper right corner. The program being displayed/changed is selected via the INC/DEC switch. Positioning the DCS up or down moves between the different fields (burst quantity, burst interval, salvo quantity and salvo interval).

The program parameters can be changed to any value within the following limits:

- Burst Quantity – 0 to 99.
- Burst Interval – 0.020 to 10.000 seconds.
- Salvo Quantity – 0 to 99.
- Salvo Interval – 0.50 to 150.00 seconds.

Note: There are also two keystrokes that are used to control electrical POWER to the jammer (if fitted) or jamming pod (if carried).

These may be used as necessary if the pilot wants to give consent to dispense chaff/flares, but not jam a threat.

Note: ECM standby (CMS right) means the ECM will not radiate (jam a threat).

ECM enable (CMS down) means the ECM will attempt to jam a threat. If the ECM (panel) power switch is OFF you will not be able to jam any threats and ECM STBY and ECM enable will have no effect, since the jammer is off. They will however still change the dispenser mode (semi from auto, consent).

1.8 LANTIRN

The Low Altitude Navigation and Targeting Infrared for Night (LANTIRN) is an imaging infrared system providing tactical aircraft with a day/night under-the-weather attack capability. Carried on the left and right chin stations, either side of the intake, LANTIRN is designed to employ a wide variety of conventional and precision-guided munitions at night using day-like tactics and deliveries. LANTIRN consists of three main components: AN/AAQ-13 navigation pod (NVP), AN/AAQ-14 targeting pod (TGP) and a wide angle raster (WAR) HUD (Block 40/42 and some export models). It will also work with the more widespread wide angle conventional (WAC) HUD.

Note: Pods are independently manually selectable from the LOADOUT screen in BMS 4.34, when available.

AN/AAQ-13 Navigation Pods will automatically be fitted to the left chin station; AN/AAQ-14 Targeting Pods will be mounted on the right chin station.

1.8.1 AN/AAQ-13 Navigation Pod (NVP)

The AN/AAQ-13 navigation pod (NVP) is installed under the engine inlet on the left side of the aircraft. It has two main components: the Forward-Imaging Navigation Set (FINS) sensor and the Ku-band Terrain Following Radar (TFR).

The FINS, a WFOV FLIR system, provides the pilot with an IR image of the terrain and airspace in front of the aircraft on the HUD. It includes a look-into-turn (LIT) mode, which enables the pilot to look in the direction of a turn and a snap-look mode which provides enhanced left, right, up, and down viewing controls while flying level, or in conjunction with LIT during turns. FINS functions include video polarity control, video gain and level adjustment options, and a grey scale capability for manual gain and level setting.

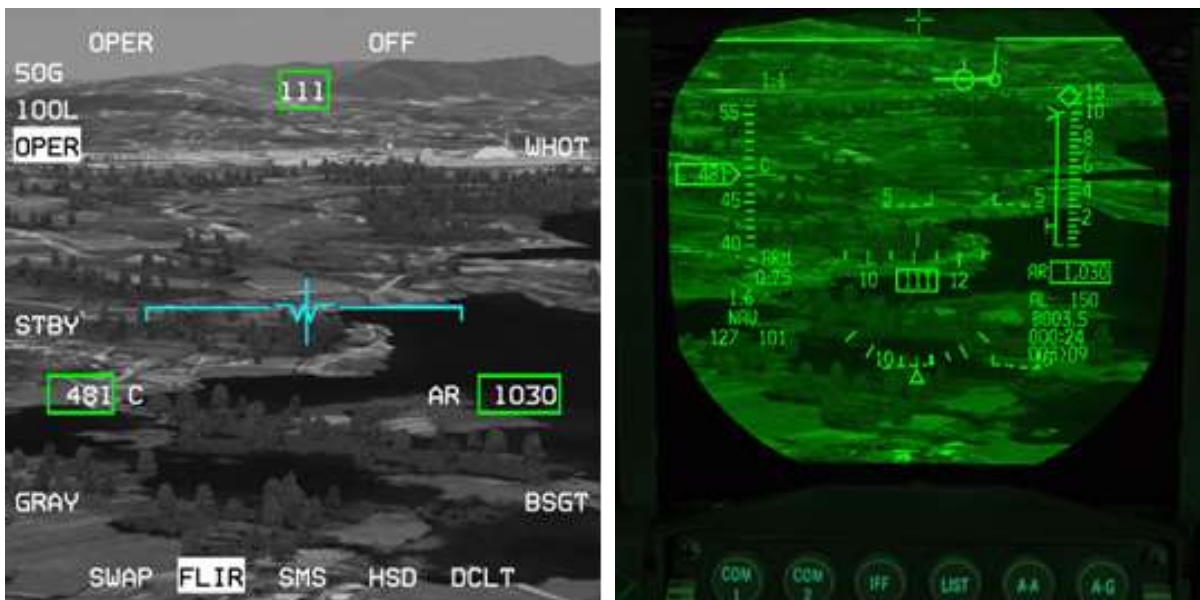

Figure 56 FLIR image in MFD and HUD

OSB 18 places the FLIR in standby. OSB 20 places the FLIR in operational mode (OPER). The FLIR needs between 8 and 15 minutes to cool down before use, so start the process as soon as possible during ramp start for missions requiring FLIR. The FLIR will be ready to operate as soon as the NOT TIMED OUT message disappears from the MFD.

Once operational the FLIR page will display the infrared view in front of the pod. The image can be repeated on the HUD by rotating the BRT ICP wheel upwards. The FLIR level can be changed with the ICP up and down FLIR arrows. The current gain and level values are displayed on the top left corner of the FLIR MFD.

1.8.1.1 **FLIR Boresighting**

OSB 10 is the BSGT (boresight) option. On the ground the FLIR camera is boresighted on top of the HUD, which may induce parallax errors. The boresight procedure is used to align the image in the HUD with the image from the FLIR camera. Do not boresight on close objects; it is advised to boresight on the furthest clearly defined object you can see along the horizon of the HUD, such as the edge of a mountain or a road to minimise distracting parallax errors.

Depress OSB10 and the BSGT mnemonic highlights; the HUD FLIR image can then be slewed with the cursors. Once both images are superimposed correctly depress OSB10 again and the BSGT mnemonic will return to its initial state.

Once the FLIR image is displayed on the HUD the MFD page does not need to be active, though it is advisable to have it on one of the DA buttons for easy access to boresighting.

1.8.1.2 **LOOK-INTO-TURN (LIT) and SNAPLOOK**

LOOK-INTO-TURN (LIT) and SNAPLOOK capabilities are available on the HUD.

LIT: when the bank angle is above 5°, holding DMS Up will shift the FLIR view slightly into the turn to provide lead obstacle clearance. The FLIR image reverts to forward looking when DMS Up is released.

SNAPLOOK: The view can be shifted further in flight by holding DMS Up and moving the cursors in any direction, even in a turn. The view will revert to forward looking when DMS Up is released.

When LIT or SNAPLOOK are active the FPM is dashed.

Please note: Terrain Following Radar is handled separately in the TERRAIN FOLLOWING RADAR (TFR) chapter.

1.8.2 **AN/AAQ-14 Targeting Pod (TGP)**

The AN/AAQ-14 targeting pod contains a high-resolution FLIR sensor, a laser designator/rangefinder for precise delivery of laser-guided munitions, a missile boresight correlator for automatic lock-on of the AGM-65 Maverick imaging infrared missiles and software for automatic target tracking. These features simplify the functions of target detection, recognition and attack and permit pilots of single-seat fighters to attack targets with precision-guided weapons on a single pass.

Note: AN/AAQ-14 LANTIRN and AN/AAQ-33 Sniper Targeting Pods are functionally identical in 4.34 so please refer to the AN/AAQ-33 SNIPER XR ADVANCED TARGETING POD chapter for information on the AN/AAQ-14 Targeting Pod.

1.9 TERRAIN FOLLOWING RADAR (TFR)

The primary function of the TFR is to detect the terrain along the aircraft flight path and to generate vertical steering commands (g-commands) for the pilot (in manual mode) or FLCS (in auto mode) to follow in order to maintain a pilot-selected altitude above the ground.

The TFR features include terrain following, obstacle warning and limited inclement weather flying. The Set Clearance Plane (SCP) settings between 200 and 1000 feet AGL are available in the normal mode. In addition to normal operation of the TFR other modes are available for specific operating conditions. These modes are Weather (WX), Low Probability of Intercept (LPI) and Very Low Clearance (VLC).

Note: TFR is only available on F-16s carrying an AN/AAQ-13 LANTIRN navigation pod (on the left chin station).

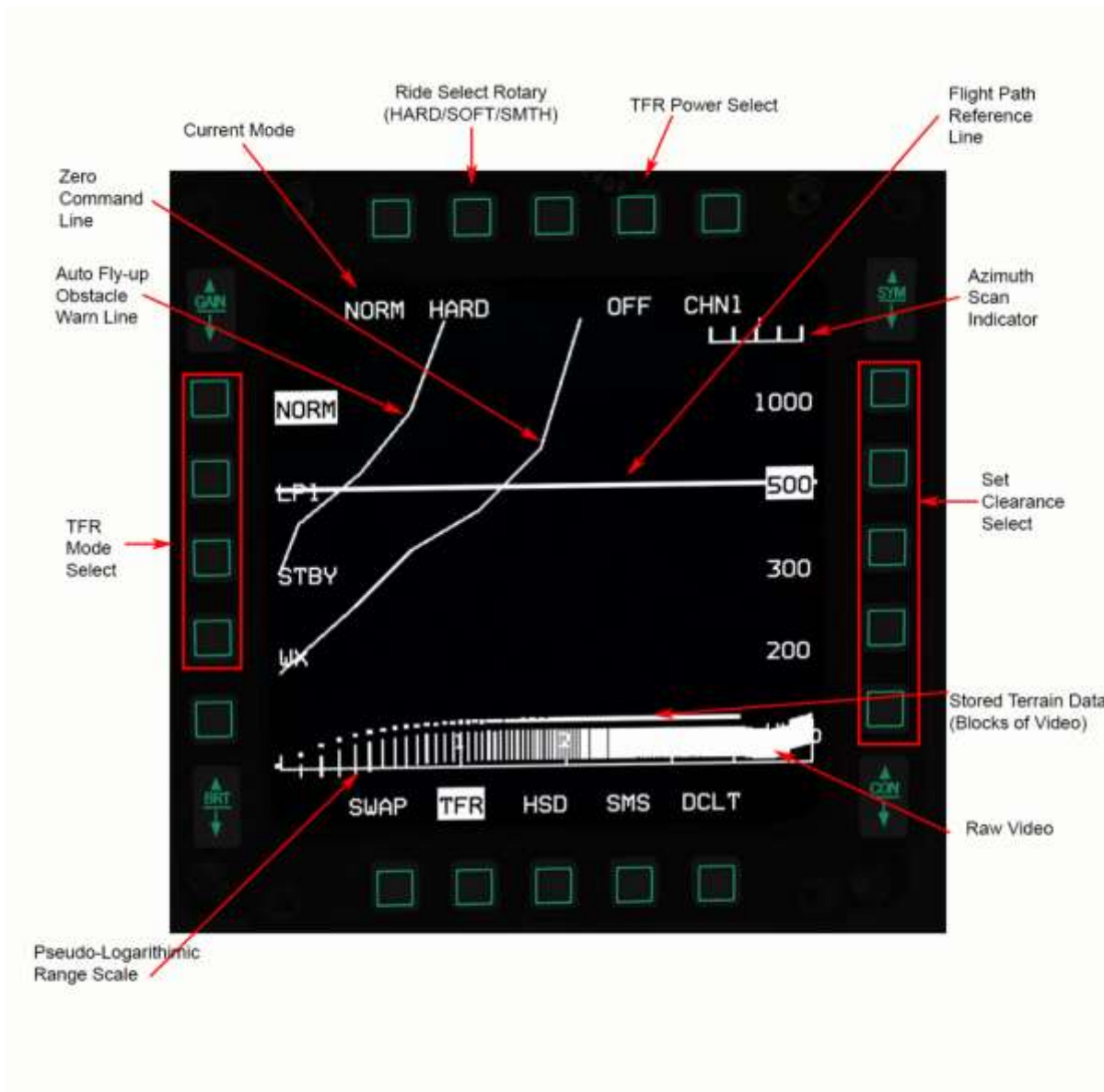

Figure 57 TFR MFD Page

1.9.1 Terrain Following Radar MFD Page

The SNSR PWR control panel located on the right console contains the power switches for the left hardpoint (LEFT HDPT) and right hardpoint (RIGHT HDPT) that are both used for the LANTIRN pods. The LEFT HDPT switch applies power to the Navigation Pod (NVP), located on the left chin pylon. The right pylon holds the Targeting Pod (TGP).

Access the TFR page via the MFD Menu Page and assign it to one of the quick access buttons (OSB 12-14). If the TFR page is accessed before power is applied to the NVP, TFR OFF will be displayed on the MFD.

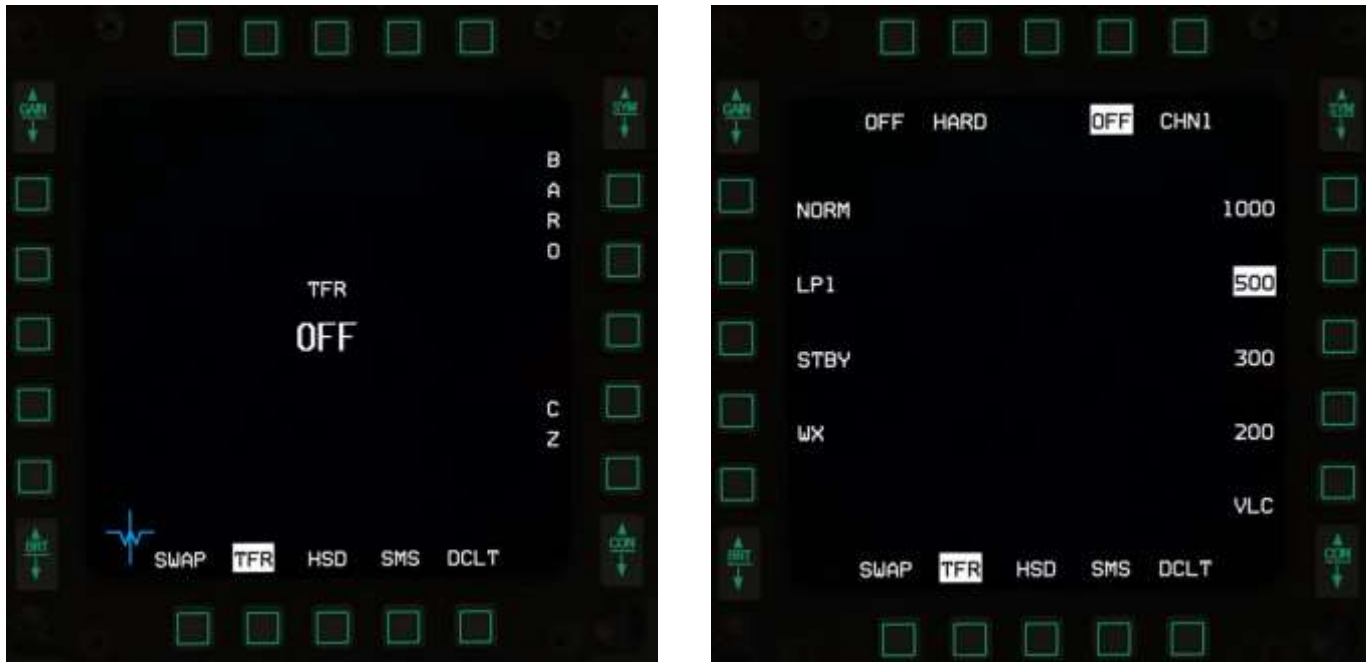

Figure 58 TFR Operation

1.9.1.1 TFR MFD Page OSB Description

- | | |
|-------------|---|
| OSB 1 | No function – displays the TFR Mode status. |
| OSB 2 | HARD/SOFT/SMTH (Smooth) Rotary. |
| OSB 4 | TFR power. |
| OSB 5 | Brings up a menu of TFR frequency channel numbers which allows the pilot to select a TFR frequency that will not interfere with other TFR radars. (N/I) |
| OSB 6 | 1000ft AGL clearance option. |
| OSB 7 | 500ft AGL clearance option. |
| OSB 8 | 300ft AGL clearance option. |
| OSB 9 | 200ft AGL clearance option. |
| OSB 10 | VLC - Set clearance of 100ft. |
| OSB 11 | DCLT (Declutter). |
| OSB 17 - 20 | TFR Mode. |

ON/OFF TFR power is controlled with OSB 4. The TFR is automatically placed in STBY mode after power on. TFR power is off when the OSB 4 mnemonic (OFF) is highlighted. TFR power ON can be also selected via OSB 18 (STBY).



Figure 59 TFR in STBY

After power is applied the TFR enters STBY mode. The NOT TIMED OUT advisory is displayed across the top of the MFD during its cool-down period. During the NOT TIMED OUT period only the ride control, clearance settings and TFR power can be selected. TFR timeout takes approximately 3 minutes.

1.9.2 TFR Operating Modes and Options

The TFR mode options are mainly selected with the OSBs along the left side of the MFD.

Note: Weather mode can be selected via OSB 17 on the TFR page, or by pressing the WX button on the ICP.

1.9.2.1 NORM (Normal)

Transmits vertical steering cues to the HUD for manual terrain-following, or g-commands to the FLCs for automatic terrain-following for day or night low altitude flight with ride control and set clearance options. Normal mode has the highest accuracy terrain following performance with turning flight capability and look into-turn.

1.9.2.2 LPI (Low Probability of Intercept)

Designed to minimise electronic detection of TFR transmission. Ride control and set clearance options are available. Because of limited transmissions turning flight is allowed at a reduced turning rate and look into-turn is not available. STRG SEL and HDG SEL functions of AUTO TF are therefore disabled in this mode.

1.9.2.3 WX (Weather)

The WX mode uses circular polarization and reductions in receiver sensitivity, processing range, and antenna up scan to minimize the interference of false returns from rain and clouds. When flying, or about to fly, through inclement weather WX mode should be engaged with the WX button on the ICP or OSB 17 to avoid uncommanded flyups.

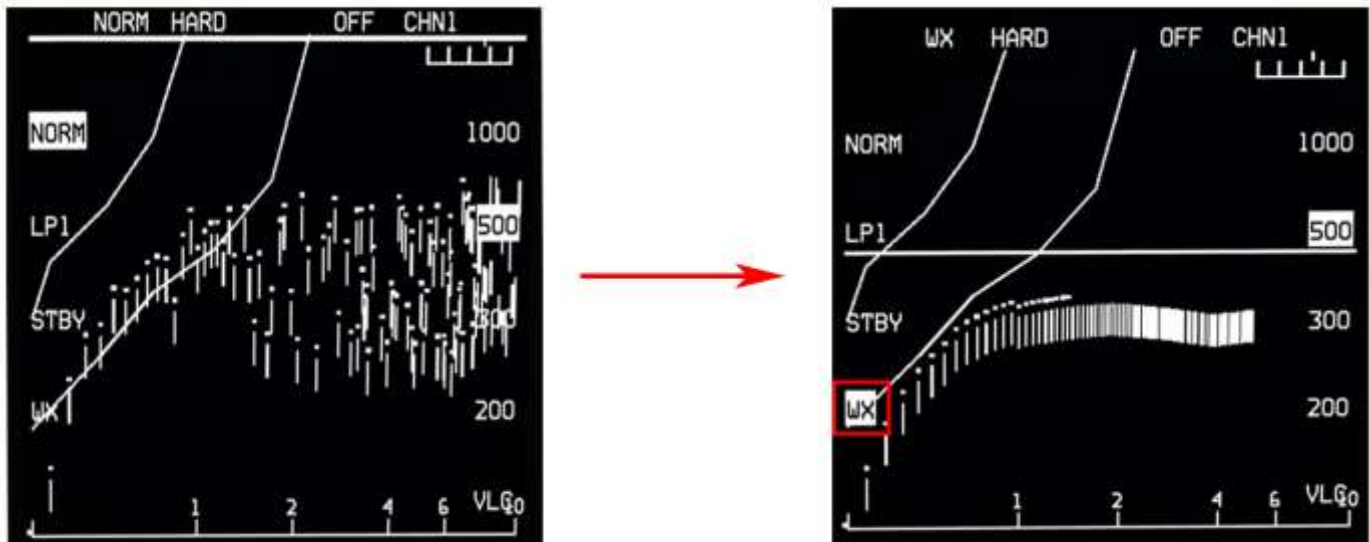

Figure 60 TFR in WX mode

1.9.2.4 VLC (very low clearance)

Not displayed as a TFR mode option, but automatically selected when in NORM and the VLC option is selected. VLC should only be used over water or extremely flat terrain. Turning rate is significantly reduced in this mode. STRG SEL and HDG SEL functions of AUTO TF are also disabled in this mode.

1.9.2.5 TFR Ride Options

The TFR ride options are selected via OSB 2 (HARD, SOFT, SMTH).

SOFT ride limits pull-up commands to 2.0 G and pushover commands to -0.5 G.

HARD and SMTH ride options both limit pull-up commands to 2.0 G and pushover commands to -0.9 G, but SMTH ride provides peak-to-peak flying. Comparing the HARD and SOFT rides, the HARD ride allows the aircraft to fly closer to an obstacle before commanding a climb.

1.9.2.6 TFR Set Clearance Options

The TFR set clearance options are selected via the OSB's adjacent to the set clearances along the right side of the MFD. The set clearance options are as follows:

1000 feet, 500 feet, 300 feet, 200 feet, VLC.

Aircraft altitude is continually monitored against the selected set clearance and a vertical clearance warning is issued if the aircraft is below 75 percent of the set clearance. A LO TF message will be displayed on the HUD and a fly-up will occur if in AUTO TF only.

1.9.3 TFR Confidence Display

The TFR confidence display provides terrain-following anticipation in bad weather via an E-squared (elevation versus exponential range) format. Terrain video is displayed across the display from right to left. The zero command line (ZCL) is displayed as a ground reference line and the horizontal flight path reference line is displayed as an aircraft reference line. Small symbols displayed with video represent processed video 'stored terrain'. The vertical lines represent unprocessed video from the primary bar that the TFR is using at the time. The unprocessed video may be used to identify weather conditions (see Figure 60 above). In addition, E-squared video is displayed in order to give the pilot confidence that the TF system is working correctly. This capability is useful when flying AUTO TF.

The terrain video, zero command line, and obstacle warn line on the E-squared display is blanked if:

- Bank angle > 85 degrees
- Drift angle > 10 degrees
- Pitch angle > 40 degrees nose up or 20 degrees nose down
- Flight vector > 40 degrees nose up or 20 degrees nose down

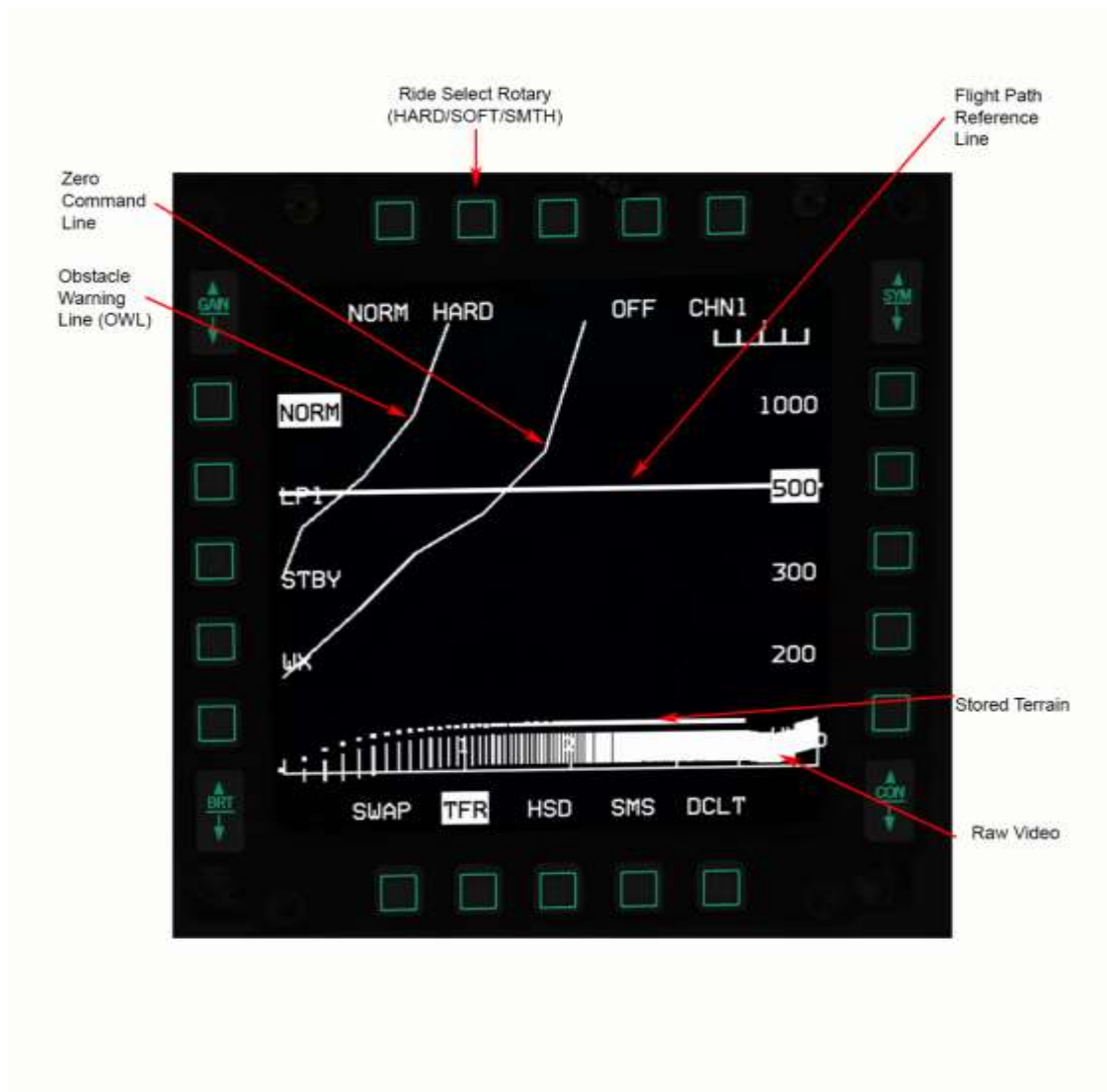

Figure 61 TFR Confidence Display

1.9.4 TFR Controls

1.9.4.1 *Advanced (ADV) MODE switch*

The ADV MODE switch, located on the miscellaneous panel, selects the desired terrain following (TF) mode. This switch is a dual-lighted push-button with the labels ACTIVE and STBY on the upper and lower halves of the switch.

The top half of the switch illuminates green when selected to indicate activation of the advanced mode (AUTO TF). The bottom half of the switch illuminates amber to indicate that the advanced mode is in standby.



Figure 62 ADV Mode Switch

1.9.4.2 *RF Switch*

When the RF switch is in NORMAL all TFR modes are available.

When the RF switch is placed in QUIET from NORM while the TFR is in NORM, VLC, or WX mode the TFR will transition to LPI. If the TFR is in LPI, STBY, or OFF when the RF switch is placed in QUIET from NORM, the TFR mode will remain unchanged. While in QUIET only requests for LPI, WX, STBY, or OFF are actioned. Function requests (clearance, ride, etc.) are honoured.

When the RF switch is moved from QUIET to NORM the TFR will remain in the last allowable mode selected while in QUIET. If no selection was made while in QUIET the TFR will transition to the last mode selected while in NORM.

When the RF switch is moved from QUIET to SILENT the TFR will transition to STBY.

While in SILENT, only requests for STBY or OFF are honoured.

Note: When the RF switch is moved from NORM to SILENT, or QUIET to SILENT while AUTO TF is selected a TF fail indication and fly-up will occur.

When the RF switch is moved from SILENT to QUIET the TFR will remain in the last allowable mode selected while in SILENT. If no selection was made while in SILENT the TFR will return to the last mode selected while in QUIET.

Table 6 TFR RF Control available modes

RF SWITCH NORM	RF SWITCH QUIET	RF SWITCH SILENT
NORM		
WX	WX	
LPI	LPI	
VLC		
STBY	STBY	STBY
OFF	OFF	OFF

1.9.4.3 *Paddle Switch*

When the paddle switch is depressed, all fly-ups are inhibited.

1.9.5 TFR Modes

The TFR has 3 modes MANUAL TF, AUTO TF and BLENDED TF.

1.9.5.1 MANUAL TF

Manual operation allows pilot control of flight and is automatically selected when TFR is operating; this is indicated by an unlit ADV Mode switch on the MISC Panel.

The HUD manual TF cue is displayed as a box symbol in which the flight path marker is flown in the centre off.



MAN TF

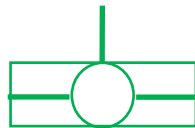

on SCP

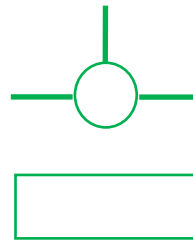

above SCP

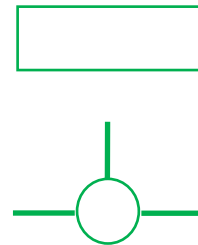

below SCP

1.9.5.2 AUTO TF

Depressing the ADV MODE switch with manual TF active engages automatic TF. The green ACTIVE light illuminates as an indication along with a horizontal line in the HUD as a TF cue.

When auto TF is engaged, the currently selected roll autopilot mode is also activated. Pitch and roll trim from the stick will be inoperative and the pitch trim wheel will be centred. Roll trim inputs can be made on the manual trim panel.

Note: due to limited turning flight capability in LPI and VLC modes, steering and heading select functions of auto TF are disabled.



AUTO TF

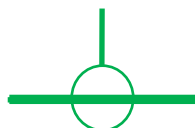

on SCP

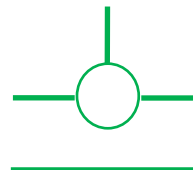

above SCP

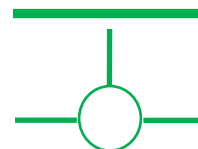

below SCP

1.9.5.3 **BLENDED TF**

The TF system can also be used in conjunction with the pitch autopilot in a blended mode. When this mode is in effect, the more positive of the TF command and the attitude or altitude pitch autopilot command is used. The autopilot will hold the selected MSL altitude or pitch attitude unless it has to fly higher to maintain selected terrain clearance. This mode also supports all three roll autopilot modes (heading select, attitude hold and steering select).

Blended mode can be entered in three ways. The first two are by turning on the pitch autopilot from manual TF or auto TF. In these cases, the STBY light illuminates. The third is to have the pitch autopilot already on when entering TF (TFR switched to an operating mode). Due to autopilot interactions, the incremental g-command range for this mode is minus 0.5g to plus 2.0g. The TF HUD cue in blended mode is the same line as in auto TF.



BLENDED TF

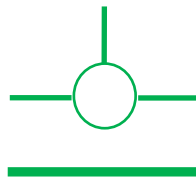

above SCP

1.9.6 **Cautions, Warnings and Advisories**

The TFR provides many cautions and warnings to maximize pilot safety. Due to antenna scan limitations, valid g-commands can only be made within certain limits of aircraft roll, dive, speed, turn rate, and turn acceleration.

When these limits are exceeded the message LIMIT appears on the HUD and flashes. If the limits are exceeded for too long the HUD TF box blanks.

Cautions, warnings and advisories are a combination of visual cues on the HUD/ MFD, aural warnings, warning light illumination and auto FLCS fly-ups.

1.9.6.1 **System Wide Integrity Management (SWIM)**

The FLCS provides a safety check on the NVP and the TF critical systems via the SWIM monitors. When malfunctions of the TF system are detected, the SWIM function provides for safe recovery and transition to manual flight control

1.9.6.2 HUD Cautions and Warnings and Advisories

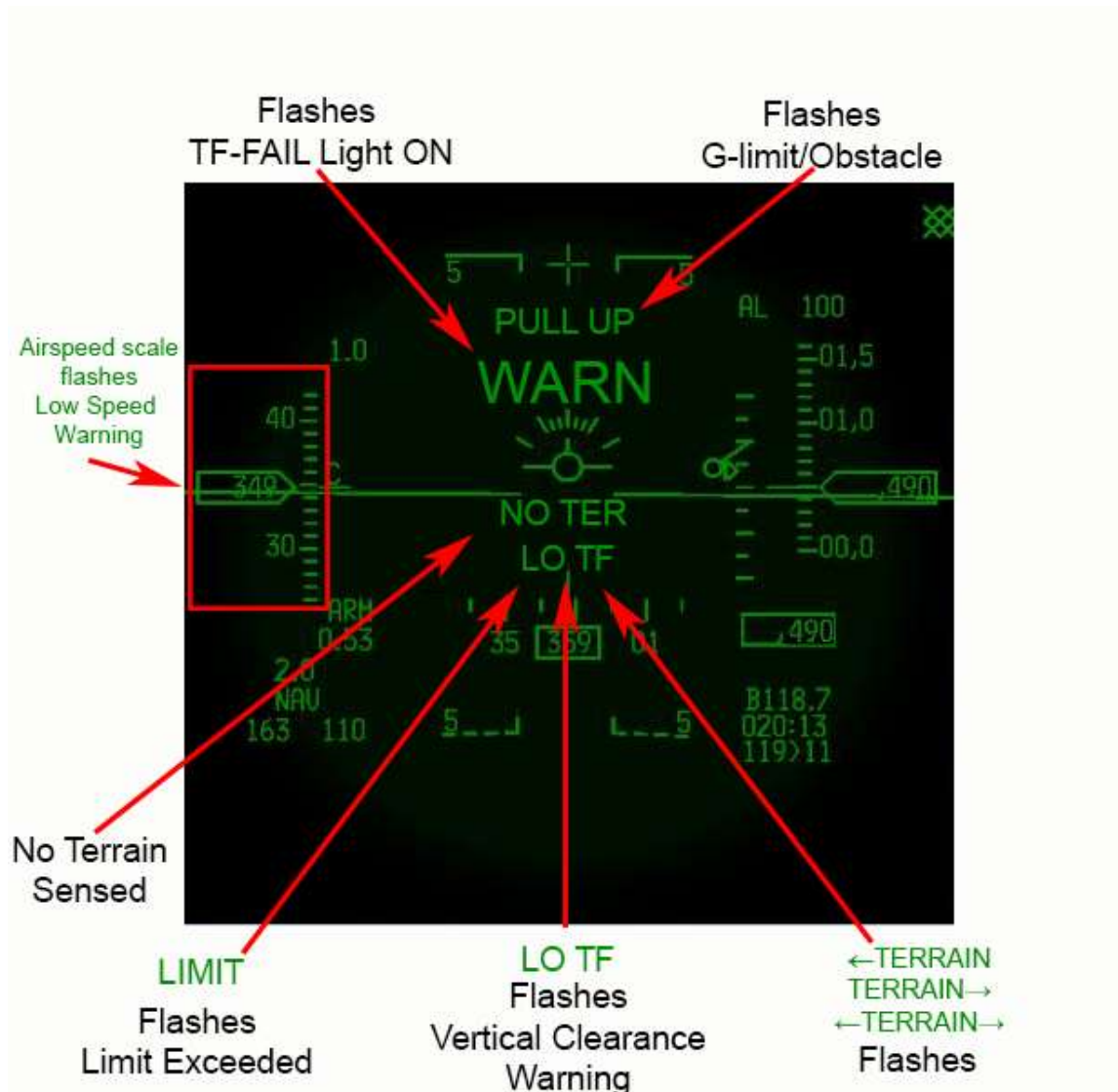

Figure 63 TFR HUD warnings

1.9.6.2.1 LIMIT

A flashing LIMIT appears on the HUD and flashes when TFR limits are exceeded. If the limits are exceeded for too long the HUD TF box blanks.

1.9.6.2.2 WARN / TF-FAIL

If the TFR fails (as detected by either the NVP or the FLCs) the TF FAIL light on the glare shield illuminates, WARN is displayed on the HUD and the aural "PULL-UP" message is activated.

1.9.6.2.3 LO TF vertical clearance warning

A vertical clearance warning is issued if the aircraft is below 75 percent of the set clearance plane. A LO TF message will be displayed on the HUD and a fly-up will occur if in AUTO TF.

1.9.6.2.4 NO TER

The NO TER message will be displayed on the HUD when the TFR is not sensing terrain within the terrain present gates. As the aircraft comes closer to reflective terrain the NO TER message should blank (the NO TER message may not blank over areas of low reflectivity such as smooth water).

1.9.6.2.5 TERRAIN

The TFR provides right and left turn advisories when terrain to the right or left of the aircraft will cause a command greater than 2.0 G. In this case, the HUD will display ←TERRAIN, ←TERRAIN→, or TERRAIN→.

1.9.6.2.6 PULLUP

PULLUP is displayed on the HUD when a G-LIMIT/OBSTACLE WARNING occurs. An automatic fly-up is issued always in AUTO TF, or in MAN TF only if the MANUAL TF FLY-UP switch is set to ENABLE.

1.9.6.2.7 Speed scale

Flashing of the airspeed scale and the word LIMIT on the HUD occurs when the aircraft velocity is below 360 KCAS.

The TFR system is designed to perform from 300 to 600 knots groundspeed. However at very low speeds (below 300 knots), where g-response cannot attain the commanded value, the set clearance of the aircraft cannot be maintained. In addition, at low speeds, fly-up capability will also be impaired.

1.9.6.3 *Aural Cautions and Warnings and Advisories*

1.9.6.3.1 PULLUP

An Aural “PULLUP” message will be heard when:

- TF-FAILS
- Limits exceeded too long (AUTO TF)
- Vertical Clearance Warning (AUTO TF)
- G-Limit / Obstacle Warning
- Low Speed Warning

1.9.6.3.2 Low Speed Tone

When the aircraft slows to below 300 KCAS the low speed warning tone is generated, all TF symbology disappears and, if in AUTO TF, the ATF NOT ENGAGED caution light illuminates.

1.9.6.4 MFD Cautions and Warnings and Advisories

1.9.6.4.1 TFR LIMITS

A flashing TFR LIMITS will be displayed on both MFDs when:

- TF Fails
- TFR limits exceeded
- TFR limits exceeded too long
- Vertical clearance warning
- Low speed advisory
- Low speed warning



1.9.6.4.2 G-limit / Obstacle warning Break X

A break X on the MFD indicates that an obstacle warning or g-limit has occurred. This will result in a 4 G or 3 G incremental fly-up, respectively, to avoid the terrain at the set clearance plane. If this warning should occur an immediate fly-up should be made (an automatic fly-up is issued if MANUAL TF FLYUP is set to ENABLE).

Table 7 TFR Warnings / Cautions / Advisories chart

	TF COMMAND CUE					HUD MESSAGE						AURAL WARNING			FLYUP			MFD MESSAGE			
	CUE BLANKED	2 G COMMAND	3 G COMMAND	4 G COMMAND	NO CHANGE	WARN	LIMIT	LO TF	PULLUP	← NO TERRAIN →	NO TER	FLASHING AIRSPEED	PULLUP	LOW SPEED TONE	NONE	ALWAYS	IF ENABLED	NONE	FLASHING LIMIT	BREAK X	NONE
TF FAIL	■					■							■			■	■		■		
LIMIT EXCEEDED				■			■							■					■		
LIMIT EXCEEDED TOO LONG	■						■						■		■				■		
VERTICAL CLEARANCE WARNING		■						■					■		■				■		
G LIMIT			■						■				■			■	■			■	
OBSTACLE WARNING				■					■				■			■	■			■	
TURN CAUTIONS					■					■				■				■			■
NO TERRAIN					■						■			■							■
LOW SPEED ADVISORY					■		■					■		■					■		
LOW SPEED WARNING	■						■						■						■		

MAN & AUTO

■

AUTO TF

■

MAN TF

■

1.9.6.5 LANTIRN TFR Attitude Advisory Function (AAF)

The AAF provides a head-down advisory to the pilot when the aircraft has exceeded specific criteria of pitch and/or roll attitudes with the TFR in operation. AAF operation is dependent on an advisory altitude. During mission planning the pilot selects an altitude at which the AAF is enabled and this is downloaded to the aircraft via the DTE. The pilot may also enter the advisory altitude into the avionic system via the ALOW DED page (ALOW button on ICP).



If there is a MMC power cycle with the gear up, the avionic system retains the advisory altitude value that was last entered into the system.

During the mission the AAF is triggered when the following conditions are met:

1. The TFR is in an operating mode (i.e. NORM, WX, VLC, or LPI) and
2. The aircraft is below the advisory altitude and
3. The aircraft exceeds either of the attitudes defined below:
 - a) $> 75^\circ$ bank and pitch $< 0^\circ$
 - b) $< 75^\circ$ bank and pitch $> -20^\circ$

This advisory consists of a flashing rectangular box containing a double set of words reading CHECK ATTITUDE, which is displayed on both MFDs. The pilot can disable the AAF by entering an advisory altitude of 0 feet.



Figure 64 LANTIRN AAF CHECK ATTITUDE

Note: this is not to be confused with the TGP Attitude Advisory. The TGP Attitude Advisory is displayed when:

- *TGP format is displayed*
- *TGP mode is A-G*
- *INS roll/pitch data is valid*
- *Aircraft exceeds either of the following attitudes:*
 - *Bank angle greater than 75° and pitch less than 0° or*
 - *Pitch less than -20°*

1.9.6.6 ATF NOT ENGAGED Caution Light

The ATF NOT ENGAGED light will illuminate immediately with any of the triggers shown below:

Note: the light will not illuminate during a fly-up.

1. ADV MODE switch is depressed when the TFR is not in an operate mode.
2. AUTO TF engaged and:
 - AR Door - OPEN
 - AOA > 29°
 - Aircraft low speed warning
 - Alt flaps - EXTEND (if below 400 KCAS)
 - Gear handle - DOWN
 - NVP low speed warning (VGS < 300 knots)
 - Trim A/P DISC – DISC
3. BLENDED TF engaged and:
 - AR Door - OPEN
 - AOA > 29°
 - Aircraft low speed warning
 - Alt flaps - EXTEND (if below 400 KCAS)
 - Gear handle - DOWN
 - STBY GAINS
 - Manual Pitch Override - OVRD
 - CADC failures
 - NVP low speed warning (VGS < 300 knots)
 - Trim A/P DISC – DISC

1.9.6.7 TFR FAULTS

Table 8 TFR Faults

PFL	MFL	EFFECT	ACTION	LIGHTS
NVP BUS FAIL	NVP 003	NVP INOPERATIVE	LHDPT OFF THEN ON. RUN IBIT.	AVIONICS FAULT
NVP COMM FAIL	NVP 014	INS DATA INVALID	CHECK INS	AVIONICS FAULT
NVP COMM FAIL	NVP 015	RALT INVALID	CHECK RALT	AVIONICS FAULT
>SWIM ATTD FAIL<	FLCS 075	AUTO FLY-UP	PADDLE PRESS CHECK NVP COMM FAIL	TF-FAIL
>SWIM RALT FAIL<	FLS 080	AUTO FLY-UP	PADDLE PRESS. CHECK NVP COMM FAIL	TF-FAIL

1.9.7 Fly-ups / Rollouts

A roll to wings level fly-up is implemented in the FLCS to avoid potential impact with terrain during unsafe operating conditions.

The commanded rollout rate for symmetric wing stores/fuel is 20 degrees per second for bank angles of 45 degrees or less. Above 45 degrees bank, the commanded rollout rate increases linearly from 20 to 35 degrees per second as bank angle goes from 45 to 75 degrees. Asymmetric wing stores/fuel will decrease the roll rate; however, even at the maximum allowable asymmetry, a minimal roll rate is still available. Beyond 75 degrees of bank, there is no rollout or fly-up. If the pilot maneuvers back within 75 degrees of bank with a failure which would normally cause a fly-up, a fly-up will then occur.

Fly-ups may be interrupted at any time by depressing the paddle switch on the stick.

Note: A roll to wings level fly-up does not occur during a LIMIT EXCEEDED TOO LONG condition in blended auto TF and pitch autopilot mode of operation.

When the TF system (either auto or manual) is operating properly, it never takes more than 2.0 incremental g's to clear a detectable obstacle in the flight path. Hence if a TF system failure is detected immediately a fly-up of 2.0 incremental g's should be sufficient to safely clear the terrain. If the TFR detects something requiring more than its normal 2.0 incremental g's to clear, it issues a g-limit warning, resulting in a 3.0g incremental fly-up. If more than 3.0 incremental g's are necessary to stay clear of the terrain, the NVP issues an obstacle warning which the FLCS turns into a 4.0g incremental fly-up. This obstacle warning could be the result of turning flight or rain if the TFR is not in WX mode.

In summary, the fly-up levels are:

- 4 G incremental – obstacle warning
- 3 G incremental – g-limit, vertical clearance warning, DBU
- 2 G incremental – everything else

All fly-ups are terminated at 300 knots or 45 degrees pitch attitude to prevent a possible stall. A departure from controlled flight may be possible if the aircraft is not controlled by the pilot beyond this 45 degree point.

In all fly-up cases the VMU will generate an aural "PULL UP – PULL UP". In auto TF these words will be accompanied by an automatic fly-up. In manual TF the automatic fly-up will only occur when the MANUAL TF FLY-UP switch is in ENABLE. Hence, when using the TFR, the pilot's first response to any aural "PULL UP– PULL UP" should be to fly-up.

Some failures will cause fly-ups which will remain latched, and other conditions will cause fly-ups which will not.

Unlatched fly-ups will be caused by g-limit, obstacle, limit exceeded too long and vertical clearance warnings. As soon as the condition which caused this unlatched fly-up is cleared, the fly-up will terminate and TF can be resumed. If the pilot interrupts an unlatched fly-up with the paddle switch, the fly-up will resume when the paddle switch is released if the conditions that caused the fly-up still exist.

A system malfunction will cause a latched fly-up. This latched fly-up command will remain until a FLCS reset (or paddle switch release for SWIM faults) is performed. If the pilot interrupts a latched fly-up with the paddle switch, releasing the paddle switch attempts a SWIM reset. If the reset is successful, TF can be resumed. If the reset is not successful, the active fly-up will not resume, but the TF FAIL light will remain illuminated and no TF commands will be present.

When radar altimeter data is invalid or missing for 1 second the terrain following system will declare a radar altimeter data bad MFL (FLCS 80), (NVP 015) and a TF RALT FAIL, NVP COMM FAIL PFL. These PFLs and MFLs are usually the result of switching the NVP to an operating mode before setting the radar altimeter to an operate mode or when a radar altimeter break track occurs. In this situation, it is appropriate to execute a SWIM reset and resume TF. If altimeter data is still missing (CARA inoperative) TF will not resume. A bad INS will also trigger a SWIM fly-up with (NVP 014), (FLCS 075) MFLs and SWIM ATTD FAIL, NVP COMM FAIL PFLs.

1.9.8 TFR Procedures

These procedures can also be found in the \Docs\02 F-16 Checklists folder.

1.9.8.1 *Before taxi*

1. Sensor power panel - LHPT ON.
2. MFD - Select TFR page.
 - (a) Press OSB 4 or OSB 18 STBY and verify NOT TIMED OUT displayed.
3. MFD - Select Test page.
 - (a) TFR OSB. Verify TFR BIT displayed for ~1 minute (TFR BIT cannot be run until TFR timeout has occurred).

1.9.8.2 *Before takeoff checks*

1. MANUAL TF FLYUP switch - ENABLE.
2. TFR - STBY.
3. SCP - 1000 feet.
4. Ride - HARD.
5. ALOW - 900 feet.
6. CARA - ON.

1.9.8.3 *TFR in-flight checks*

1. After takeoff accelerate to 350 KCAS and climb above 1000 feet AGL.
 - (a) CARA - verify reading ± 50 feet over known elevation.
 - (b) TFR - NORM, verify:
 - (1) Flashing LIMIT and airspeed scale displayed in HUD.
 - (2) Flashing TFR LIMITS displayed on MFDs.
 - (3) TF command box (manual TF) appears.
2. Accelerate to 400 KCAS and verify flashing airspeed limits disappear accelerating through 360 KCAS.
3. Bank aircraft past 60 degrees.
 - (a) Flashing LIMIT displayed in HUD.
 - (b) Flashing TFR LIMITS displayed on MFDs.
 - (c) TF command box (manual TF) disappears when turn held for more than 2 seconds.

4. Roll out and verify flashing turn limits disappear when TFR within limits and TF command box reappears.

5. Accomplish the following check over level terrain (if possible):
 - (a) AMS - Depress (verify ACTIVE light illuminates and AUTO TF line is displayed).
 - (b) Verify ground return in E-squared scope and NO TER not present in HUD.
 - (c) Verify aircraft commands level off at 1000 feet SCP.
 - (d) Establish gradual descent by pushing stick and verify:
 - (1) Aural ALTITUDE message at 900 feet AGL (ALOW).
 - (2) Vertical clearance fly-up at 750 feet AGL (LO TF HUD advisory, TFR LIMITS on MFDs and aural PULLUP MESSAGE).
 - (e) Allow fly-up to level/climbing attitude, then paddle switch - Depress (STBY light illuminates).
 - (f) AMS - Depress.
 - (g) Paddle switch - Release and verify ACTIVE light is out and manual TF box displayed.
 - (h) Re-establish descent (push over) until approximately 500 feet AGL and verify:
 - (1) G-LIMIT/OBSTACLE WARNING fly-up occurs.
 - (2) PULLUP displayed on HUD.
 - (3) Flashing break X displayed on MFDs.
 - (4) Aural PULLUP message.
 - (i) Allow fly-up to level/climbing attitude, then paddle switch - Depress.
 - (j) SCP - Select minimum mission SCP.
 - (k) Paddle switch - Release.
 - (l) Follow manual TF command box to minimum mission SCP and check for correct level flight programming.

6. Establish 15-30 degree bank and perform RALT TEST (TEST page > OSB 7 RALT) and verify:
 - (a) Manual TF command box disappears and SWIM failure roll to wings level fly-up occurs.
 - (b) Aural PULLUP message.
 - (c) WARN displayed on HUD.
 - (d) TF FAIL warning light illuminated.
 - (e) TF FAIL PFL on PFLD (only if below 4500 feet AGL).

7. Paddle switch - Depress and hold.

8. Paddle switch - Release when RALT TEST is complete.

9. Mission parameters - Verify/select:
 - (a) ALOW - As required.
 - (b) Ride - As desired.
 - (c) SCP - As desired.
 - (d) TFR mode - As desired.

1.10 AN/AAQ-33 SNIPER XR ADVANCED TARGETING POD

1.10.1 Background

The AN/AAQ-33 Sniper Extended Range (XR) ATP is an electro-optical targeting system in a single, lightweight pod that is compatible with the latest precision-guided weapons for detecting, identifying and engaging multiple moving and fixed targets in air-to-air and air-to-ground engagements.

With capabilities including long-range target detection and identification and continuous stabilized surveillance, Sniper enables aircrews to find and destroy targets outside of jet noise ranges.

Sniper contains a diode-pumped laser with cockpit selectable tactical and eye-safe wavelengths, a laser spot tracker for acquiring laser designations from other aircraft and laser marker (IR pointer) illumination for night vision goggles and target coordination.

The Sniper XR ATP installs under the engine inlet on the right side of the aircraft as with previous targeting pods, yet is considerably narrower in diameter and lighter in weight, offering corresponding drag benefits.

1.10.2 TGP Base and Control pages for Sniper XR ATP

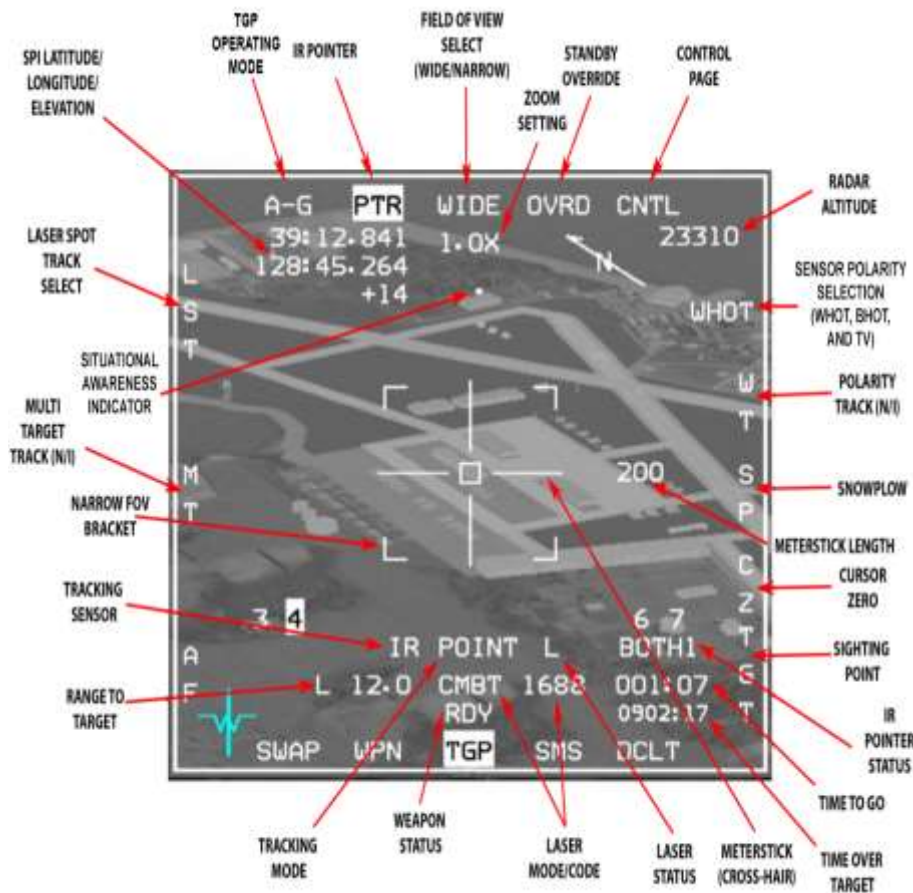

Figure 65 Sniper XR Base Page

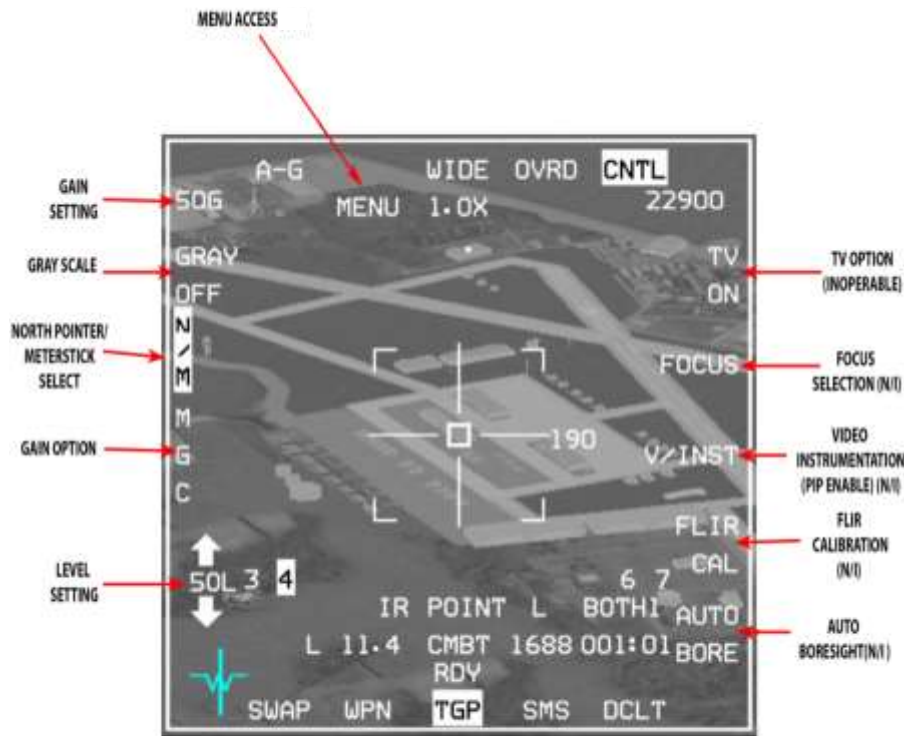

Figure 66 Sniper XR Control Page

Note: the AN/AAQ-14 LANTIRN Targeting Pod is functionally identical to the AN/AAQ-33 Sniper in BMS 4.34, though the wider and heavier AN/AAQ-14 LANTIRN Targeting Pod will incur an additional 3 points of drag when fitted.

1.10.2.1 Operating Mode / Menu Page

OSB 1 displays the current operating mode and accesses the Mode Menu page. The TGP Mode Menu page provides switching between TGP modes and displays only those modes available. Operating mode selection is Master mode dependent; for the A-A Master mode, the TGP may be in A-A or STBY; for the A-G Master mode, the TGP may be in A-G or STBY; and for the NAV Master mode, the TGP may be in A-A, A-G, or STBY.

1.10.3 FLIR Sensor

The FLIR sensor detects relative temperature differences between an object and its surroundings and displays them, roll-stabilized, as different shades of grey on the MFD TGP page.

The FLIR video can show white objects as hot (WHOT) or black objects as hot (BHOT). Polarity can be changed by pressing OSB 6 hands off or by TMS-left on the HOTAS (with TGP as SOI).

1.10.3.1 **Gain and Level Control**

Gain and level control allows you to adjust the gain and level of the picture. For now real gain and level values have no effect on the picture. Level values may change by using OSBs 16 and 17 when in MGC (Manual Gain Control) mode, but will have no effect on the video image. Gain control may be switched between MGC and AGC via OSB 18.

1.10.3.2 **Field of View (FOV)**

The Sniper has 2 FOVs for the FLIR sensor: Wide and Narrow. The FOV can be switched between WIDE and NARO via OSB 3 or with the Expand/FOV switch (Pinky) on the HOTAS. WIDE or NARO will display above OSB 3 accordingly. The wide FOV is 3.6° x 3.6° degrees, while the narrow FOV is 1.0° x 1.0°.

Note: Although Sniper XR is simulated, for now actual XR capability isn't implemented.

1.10.3.3 **Variable Zoom**

The Sniper provides electronic zoom control that can be changed from 1x to 4x using the MAN RANGE/UNCAGE knob on the HOTAS. The variable zoom stays the same between sensor changes and the variable zoom setting label appears below the FOV label under OSB 3.

1.10.3.4 **TV Sensor**

The TV sensor can be selected by pressing OSB 6 or by clicking TMS-Left twice in less than 0.5 seconds. The TV has only 1 FOV 0.5° x 0.5° and one polarity, so TMS-Left will not change anything in this mode. Variable zoom can expand the picture from 1x to 4x. When switching to TV, IR FOV and polarity are saved and will be restored when switching back to the IR sensor.

1.10.3.5 **North Pointer / Meterstick**

By selecting N/M via OSB 19 in the Control page the longitude, latitude and elevation of the current System Point Of Interest (SPI) position will be displayed in the upper left corner of the MFD display along with an arrow pointing north in the upper right corner and a number to the right of the meterstick (cross-hair) which is the length in meters of each line of the cross-hair.

1.10.4 Laser Designator/Ranger

1.10.4.1 Laser Characteristics

The Sniper XR ATP provides a laser transmitter and receiver operating at both combat and eye-safe wavelengths. The laser is used for ranging for navigation updates, for mark points, designating for some weapons and for LGB delivery.

The laser and LST codes and modes may be set in the DED laser page. The laser may be set to any allowed code (1511-1788) and the beam may be for training or combat.



Figure 67 Laser DED page

1.10.4.2 Combat/Training Laser Mode Selection and Status Indication

The laser mode is set to Training by default for both AA and AG modes. The pilot can change the laser code to Combat for AG submode by placing the asterisks on the laser mode label and pressing any numeric key (1-9) on the ICP.

When the laser is armed additional information is included on the lower part of the pod display, below the track status field. The laser mode (CMBT or TRNG) is displayed along with the selected laser code (combat laser only).

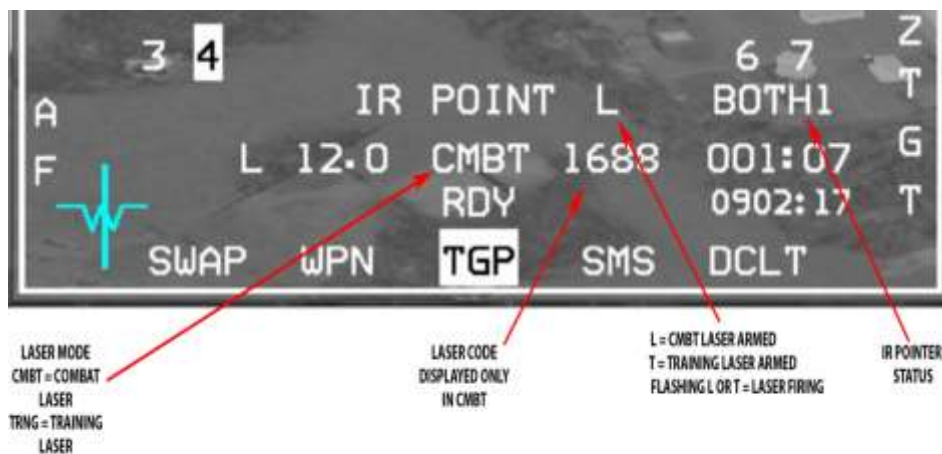

Figure 68 Laser Mode & Code and Laser/IR Pointer Status Indications

Since the combat mode laser is not eye-safe (in the real world), even for scattered/reflected energy, it is imperative that the laser beam not strike the aircraft. To accomplish this safety consideration the TGP determines if it is looking at the aircraft structure or stores. When the TGP LOS is pointed at the aircraft, laser fire is inhibited. The mask zone blocks off the area surrounding the wing tanks on stations 4 and 6 and a LANTIRN navigation pod on station 5L. All other stores are blocked by the wing tanks. Indications of a masked condition includes an M on the TGP page to the right of the L or T in the bottom right portion of the MFD and MASK adjacent to the flight path marker on the HUD. There is a warning zone outside of the actual mask zone which alerts the pilot that a mask condition is approaching. When in the warning zone the TGP crosshairs flash and MASK flashes on the HUD. When conditions warrant for a MASK condition, MASK is displayed steadily on the above mentioned displays.

When the laser is armed a laser status indication (L for combat or T for training) will appear to the right of the track status label. The L or T will flash whenever the laser is firing (manual or automatic mode). If the IR Pointer is enabled a PTR label will be displayed under the station numbers in the right bottom corner of the display; when the IR pointer is fired then the PTR label will flash.

When changing laser status the CMBT or TRNG labels will flash for a couple of seconds on the MFD and on the DED. While the status is changing the laser is unavailable to fire and the laser status L T label will blank from the display.

L or T will also appear in the lower right corner of the HUD and will also flash when the laser is firing. When the IR Pointer is selected a P will appear next to the L or T and the P label will similarly flash when the IR Pointer is fired.

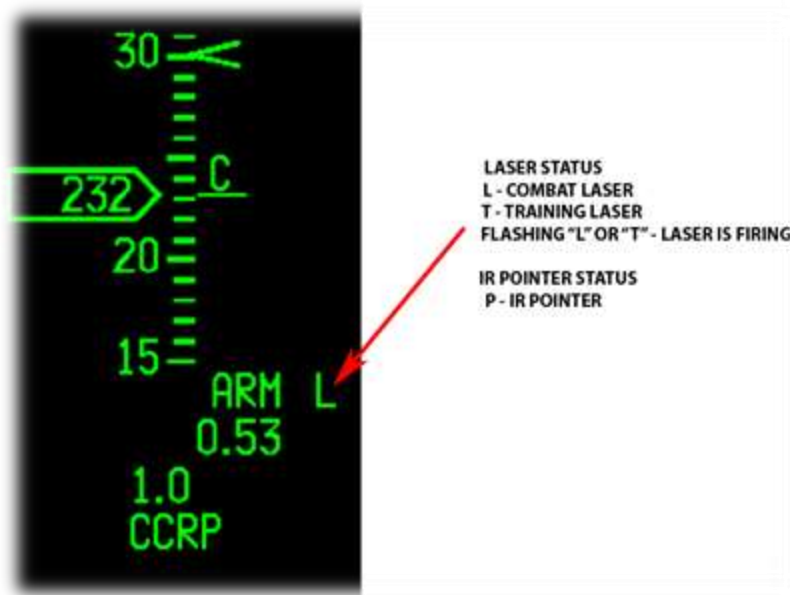

Figure 69 Laser/IR Pointer Status On HUD

1.10.4.3 **Laser Operation**

The following conditions must be met in order to fire the laser:

- LASER ARM switch in the LASER ARM position.
- A-G – MASTER ARM switch in the ARM or SIMULATE position.
- A-A – MASTER ARM switch in the ARM position, pod is tracking.
- Weight off wheels.
- Pod LOS not masked.
- Altitude at 50,000 feet or below.
- Pod not in LST mode.

The laser and IR Pointer are fired by pressing the first trigger detent. The laser will also fire by holding the pickle until bombs are released.

1.10.4.4 **Laser Ranging**

When the laser is firing and the laser beam can reach the SPI position (laser is valid) an L will replace the T on the TGP MFD page next to the range in the lower left corner. This indicates that the aircraft is measuring range to the SPI position using the laser beam, which is the most accurate ranging sensor and takes precedence over other sensors. When laser ranging happens then the range to SPI (slant range) information in the lower right of the HUD will be preceded by an L as well.

Note: in order for the laser to be valid, the range to the lased spot must be sufficient and the laser beam must have a clear path. Cloud cover or even single clouds which are in the way of the beam may interrupt and prevent the laser being valid. If the laser isn't valid, laser ranging isn't working so no L will precede the slant range value.

1.10.4.5 **Laser Guided Bombs Operation**

To guide LGBs the A-G laser must be set to CMBT and the laser code must match the laser code that was set for the bombs (using the SET CODE button on the LOADOUT screen) or the bomb(s) will not guide on the laser spot.

During LGB delivery the laser is designed to fire automatically for terminal guidance at the pre-defined time from bomb impact that is set on the laser DED page; the laser will keep firing until 2 seconds after the expected impact time. The pilot can choose to fire the laser manually by using the first trigger detent after bomb release. Pressing the pickle will also cause the laser to fire, but only until the bombs release, then the laser will stop firing even if the pickle is kept depressed. The laser will fire only if all conditions to fire the laser are met.

Note: A flashing L doesn't always indicate that the laser spot is valid for LGB guidance; it only indicates that the laser is firing. In order to make sure the laser is valid, the pilot should verify that the laser is ranging.

1.10.5 IR Pointer

1.10.5.1 IR Pointer Characteristics

The Sniper can fire an IR Pointer beam that can be detected by NVGs. IR pointer status can be selected by pressing OSB 2 on the MFD or by 2x TMS-Right < 0.5 seconds. The IR pointer is disabled in CCIP and CCIP-rockets mode and also if the laser is fired for self-designated LGB delivery in auto-lasing mode, unless the BOTH option is selected.

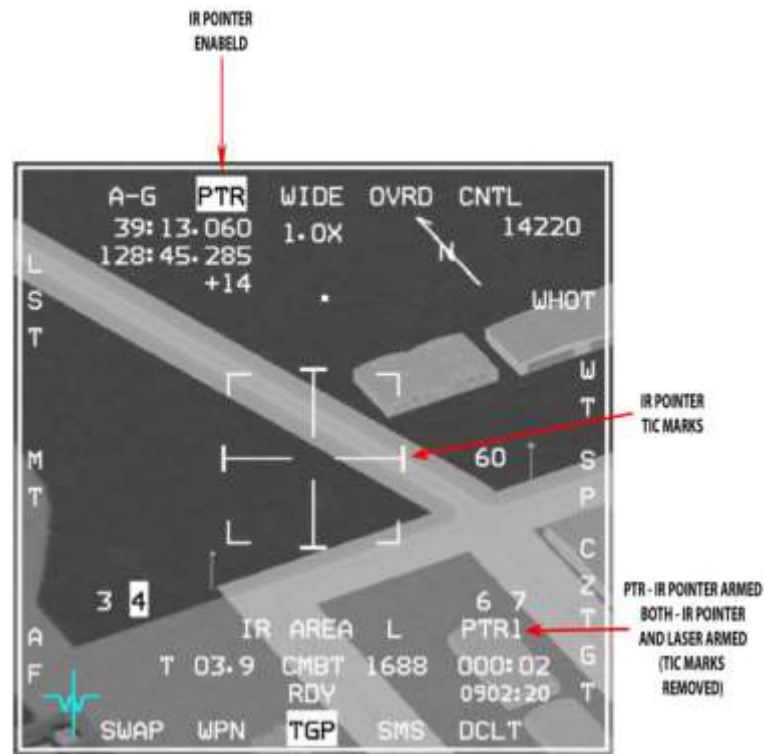

Figure 70 IR Pointer Indications

1.10.5.2 Use of IR Pointer with Laser Designator/Ranger

When the IR pointer is selected, the PTR label under OSB 2 will be highlighted and a number 1-4 will show up in the lower right corner next to PTR. The number 1-4 indicates the flash pattern that the PTR is using; this way it's possible to distinguish between 4 different IR pointers being fired at the same time. A P label is displayed in the bottom left corner of the HUD when the IR Pointer is enabled and the P will flash when the IR Pointer is being fired.

1.10.5.3 Switching between IR Pointer and the designating laser

The IR Pointer status can be selected hands-off with OSB 2 and on the HOTAS via 2xTMS-Right < 0.5 seconds. The options for IR Pointer are:

- Disabled – PTR label not highlighted under OSB 2.
- Enabled – PTR label highlighted under OSB 2.

- BOTH – BOTH label under OSB 2.

The IR Pointer is fired by pressing the trigger detent to either position. When the IR Pointer is fired, the PTR or BOTH labels under OSB 2 and in the lower right corner of the MFD will flash. If BOTH mode is selected the IR Pointer and laser can be fired simultaneously. IR Pointer firing is independent of the LASER ARM switch position. IR Pointer will be inhibited during auto-lasing while the Sniper is self-designating for an LGB attack.

1.10.5.4 IR Pointer Operation

The following conditions must be met in order to fire the IR Pointer:

- Pod not in LST mode.
- IR Pointer enabled (Tick marks at the end of the cross-hairs or BOTH mode).
- Weight off wheels.
- Pod LOS not masked.

Note: The IR Pointer arm and fire regardless of the Laser Arm switch position.

1.10.6 Sniper XR ATP Controls and Displays

Control	Functionality	Condition
TMS-Up & hold	Commands AREA track mode	A-G mode only
TMS-Up & release	Commands POINT track on centre of FOV	
TMS-Right	Commands AREA track mode	A-G mode only
2x TMS-Right < 0.5 seconds	Toggle IR Pointer mode: PTR unlit → PTR highlighted → BOTH → PTR unlit	
TMS-Left	Toggle Polarity	IR Sensor only
2x TMS-Left < 0.5 seconds	Change sensor: IR → TV → IR	
TMS-Aft	Break track and return to slave mode	
Trigger first detent	Fire Laser or IR pointer or both	
Trigger second detent	Fire Laser or IR pointer or both If depressed in CCIP mode the laser fire is latched for 30 seconds	
Expand/FOV	Toggle FOV Wide → Narrow → Wide	IR Sensor only
WPN REL	Fire laser	CCRP or DTOS modes only until bombs are released
CURSOR/ENABLE	Slew SPI if in Slave mode Slew pod tracker if in track mode	
MAN RNG/UNCAGE Rotate	Change variable zoom	
MAN RNG/UNCAGE Press	Toggle LST mode	

Table 9 Sniper XR ATP Controls

1.10.7 Pod Modes

1.10.7.1 Modes

Standby (STBY): Standby mode is the default mode when the pod is powered up.

Air to Ground (A-G): pilot selected. The pod is configured for A-G operations while in this mode. The pod is capable of entering all submodes and functions.

Air to Air (A-A): pilot selected. The pod is configured for A-A operations while in this mode. While in A-A mode the pod cannot: fire the laser in CMBT mode, fire the IR Pointer, or enter AREA or LST modes. In A-A mode if there is a bugged target the TGP will display the target, otherwise the LOS will be positioned 3 degrees below the aircraft boresight (gun cross).

1.10.7.2 Submodes

The pod's submode is closely tied to how the pod LOS is controlled. The following submodes are available with the Sniper XR ATP:

- Slave (A-A and A-G modes)
- LST (A-G mode)
 - LST Search (LSRCH)
 - LST Track (LTRACK)
- Point Track (A-A and A-G modes)
- Area Track (A-G mode)
- Inertial Rates (A-A and A-G modes)
- Menu Selection

1.10.7.3 Slave Submode

In slave submode the Sniper follows the System Point Of Interest (SPI) position. In A-G mode the SPI position is determined by the current sensor that controls the SPI. In A-A mode the Sniper is slaved to a bugged target or will centre just below the aircraft boresight.

Note: In slave submode the pods tracker isn't actually working and the pod tries to maintain its position without it, so there may be unwanted wobble movements when the aircraft accelerates in any axis direction (when the control surfaces are moving via input commands, either from pilot input or from other aircraft systems). The wobble should stop when acceleration stops.

Note: When the pod is slewed in A-G mode and slave submode, the pod LOS isn't moving directly as it does in tracking modes, the aircraft SPI is slewed indirectly and the pod tries to maintain the LOS aimed to that point. Because of this indirect slewing of the SPI, the slewing is more similar to the way the A-G radar is slewed rather than normal pod slewing. For example, if the SPI position is behind a mountain which denies direct LOS, slewing the pod in

slave submode will keep moving the SPI although the pod itself can't really follow the point. If you then enter a tracking submode, the pod's LOS will align its position (and the SPI position) on the mountain that covered the initial point. The pod's geographical coordinates will reflect this difference in the position that the pod is following.

1.10.7.4 Laser Spot Tracker (LST) Submodes

The Sniper provides LST capability. The LST can detect and track laser spots being designated by other aircraft in BMS. The LST detection FOV is 3° and the code of the fired laser must match the LST code that is set on the DED Laser page. The LST code range is 1111-1788.

When using the LST the laser and IR pointer cannot fire.

LST mode is only available when the pod is in A-G mode, the pilot can select LST mode hands-off via OSB 20 or hands-on by pressing the MAN RNG/UNCAGE knob.



Figure 71 Laser Codes on the DED Page

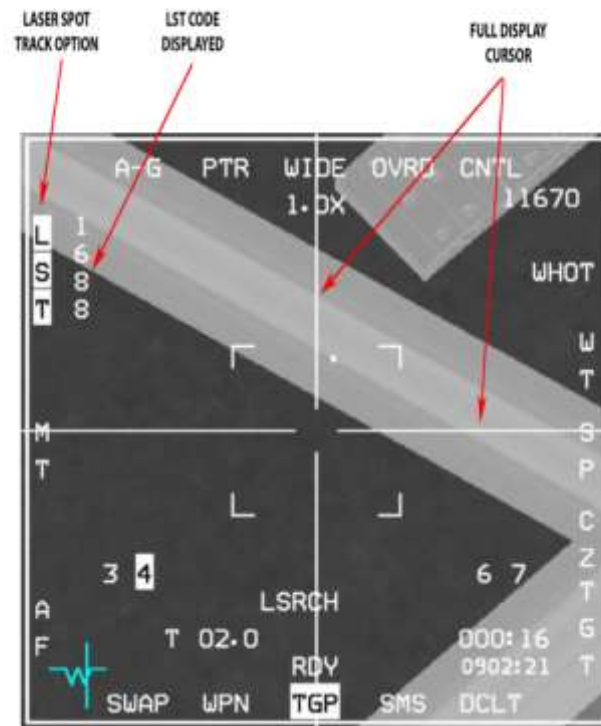

Figure 72 Laser Spot Track Selection

When in LST mode the LST code is displayed vertically adjacent to the LST label near OSB 20 on the TGP base page and the crosshairs are extended to the edges of the MFD. The LST label highlights when LST mode is on.

When the LST function is started, the pod starts a search for a laser illuminated spot inside a 3° FOV around the SPI position. When a laser spot with laser code that matches the LST laser code is detected the Sniper tracks the spot and a small tracking box is displayed at the crosshairs. LST mode is exited when the pilot commands AREA or POINT track, enters slave mode with TMS-Aft, or by pressing the MAN RNG/UNCAGE knob or OSB 20. Three TGP messages are displayed at the lower centre area of the display to provide the status of the Laser Search and Track. These include LSRCH for LST search, DETECT for LST detection of laser energy prior to full track and LTRACK for LST track.

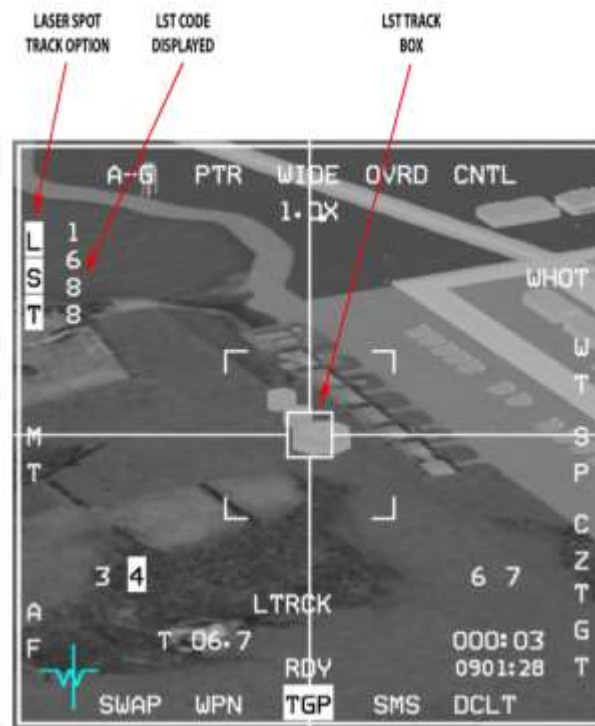

Figure 73 Laser Track Display

Note: The SPI position and the LST tracked spot position may not coincide. FCC solution and HUD symbology reflects the SPI position and not the LST track spot position. The pilot should command AREA or POINT track before dropping ordnance on the SPI.

The HUD also provides LST symbology. If the LST laser spot is inside the HUD FOV, a target identification set, laser (TISL) symbol is displayed. If the target is outside the HUD FOV then the TISL will be displayed with an X mark on it and it will be located at the edge of the display in the direction of the tracked spot position. In addition, a TLL line is displayed from the bore cross in the direction of the target, and the angle to the target is indicated to the left of the bore cross.



Figure 74 LST Indications in the HUD

1.10.7.5 Point Track

POINT track mode tracks single objects with well-defined edges, e.g. vehicles, some buildings. When POINT Track is established a box grows from the centre of the crosshairs until the edges of the target are enclosed by it. The TGP tracker continuously updates the tracker box such that, when the aircraft is maneuvered, the tracker box changes to the new viewing aspect of the target. POINT is displayed below the crosshairs, indicating that track has been established. Designating with TMS-up and hold, with TGP SOI, commands AREA track to ground-stabilize the LOS. POINT Track is commanded by releasing TMS-up.

If the TGP cannot maintain POINT track because LOS to the target is blocked (pod masked or target hidden behind another object for example) then the pod will drop POINT track and switch to INR or AREA track until the pilot commands POINT track again on the target; it will not return to POINT unless a new POINT Track command is initiated. If the pilot commands slewing when in POINT track then the pod will drop the track and will try to reacquire POINT track once the slewing stops.

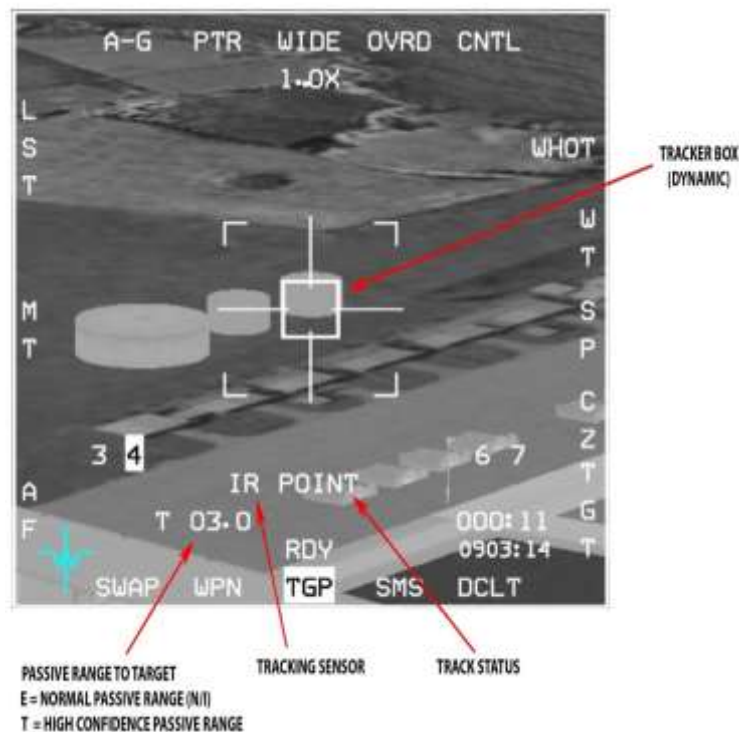

Figure 75 Point Track Display

TMS-aft commands the TGP to break track and return to the SLAVE mode, meaning it is slaved back to the radar LOS. If the target cannot be POINT tracked because the target does not have sufficient edge detail, the TGP automatically defaults to AREA Track.

Note: you can drop munitions on a target in either AREA or POINT track mode.

1.10.7.5.1 A-A Mode

The TGP A-A mode provides visual target identification and tracking of A-A targets. In A-A the TGP is initially commanded to the FCR LOS if the FCR is tracking an A-A target. If the TGP is not the SOI and the FCR is not tracking a target, the TGP LOS is positioned to 0 degrees azimuth and -3 degrees elevation. The TGP can track and maintain an A-A target independent of the FCR LOS, resulting in two A-A TD (target designator) boxes/TLL's (target locator lines). Once the TGP has been commanded to track, the TGP LOS and the FCR LOS are independent. The TGP LOS is shown as a dotted 50-mr A-A TD box in the HUD. If the TGP LOS is outside the HUD field-of-view, a dotted TLL and target angle are displayed. The FCR A-A TD box is a solid 50-mr box.

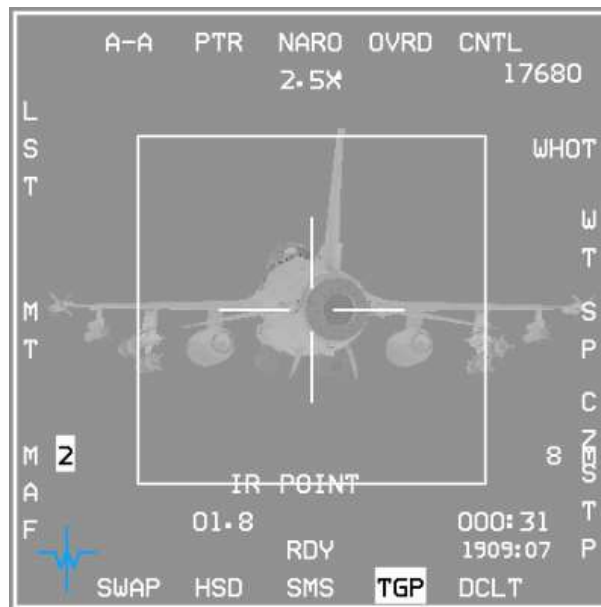

Figure 76 TGP in A-A Mode



Figure 77 TGP TD Box in HUD – TGP in A-A Mode

1.10.7.6 Area Track

AREA track can track areas which aren't capable of being point tracked (POINT track fails to track them) or when POINT track is not desired (for example if you are targeting a bomb in between two point-trackable vehicles).

AREA track is often commanded first in order to help stabilize the TGP display before you find a specific target to be POINT tracked. AREA track may be also used for POINT trackable targets where AREA track provides higher precision for tracking a specific part of a large object, like a building. When the AREA tracker is controlling LOS, AREA is displayed below the crosshairs near the bottom of the TGP page. AREA track is not available when the pod is in A-A mode.

AREA track is commanded by TMS-Right on the side stick controller when TGP is SOI. The pod will also enter AREA track with TMS-Up and hold (release commands POINT track) if the pod is in A-G mode.



Figure 78 Area Track Display

1.10.7.7 Inertial Rates (INR)

Sniper also has an Inertial Rates (INR) track mode. INR track is entered automatically when the pod cannot track the scene with POINT or AREA tracking modes. This happens most often when the aircraft structure or stores mask the target. When in INR track the POD LOS will usually drift slowly away from the target and you will usually have to manually slew back to the target and reacquire a point or area track when you exit the mask situation.

1.10.8 AGM-65 Hand Off

If the targeting pod is tracking an IR target and an AGM-65D/G is the selected weapon the AGM-65's LOS can be slaved to the targeting pod LOS. The avionics system then routes the missile video to the TGP. The pod's missile boresight correlator then compares the AGM-65 video to the TGP video, aligns the AGM-65 to the same target and commands the missile to track.

During a hand-off the message HANDOFF IN PROGRESS STATION X (where X is the appropriate missile station) is displayed on the weapon (WPN) page. Hand-off status is displayed above the station number on the TGP page.

The following summarizes status indications:

- S** – Slave, the missile isn't tracking.
- 1** – Slew, the TGP is moving the missile LOS based on comparison of the Missile LOS and the TGP LOS.
- 2** – Slew, TGP is moving the missile LOS based on comparison of the Missile video and the TGP video (N/I).
- T** – Track, the TGP has commanded the missile to track.
- C** – Complete, Hand-Off is complete, missile is tracking.

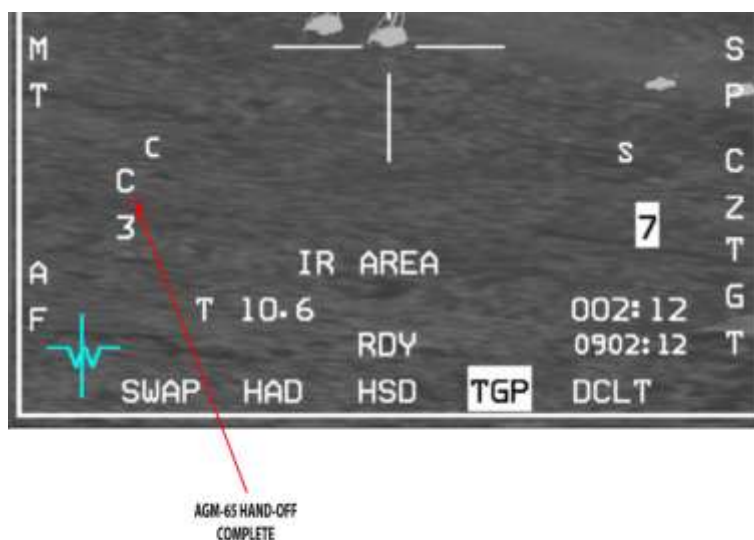

Figure 79 AGM-65 Handoff Status

1.10.9 Miscellaneous Symbology

Range to CFOV (Centre Field of View) Symbology is displayed in the lower left area of the video display. If the pod is in A-A or A-G mode and laser range is valid the TGP will display the range preceded by an L. A valid laser range will take precedence over the other range types. If laser range isn't available but the pod is tracking in A-G, the pod will display a computed range, preceded by a T. If the pod isn't in track mode and SPI range is available from the aircraft, the pod will display that. Range is displayed in nautical miles and tenth of nautical miles, unless the range is less than one nautical mile. If the range is less than a mile then the range is displayed in hundreds of feet with no decimal place.

1.10.9.1 Situational Awareness Indicator Symbology

Situational awareness indicator (SAI) symbology is displayed whenever the pod is in A-A or A-G modes. The SAI is a 6 x 6 pixel square which represents the pod's LOS relative to the body of the aircraft. The position of the SAI can be thought of as a tip of the unit vector (arrow shown below) in the direction of the LOS, viewed from above the aircraft looking down, projected on to a plan defined by the aircraft X-Y coordinates system.

Figure 80 shows TGP LOS positions relative to the aircraft.

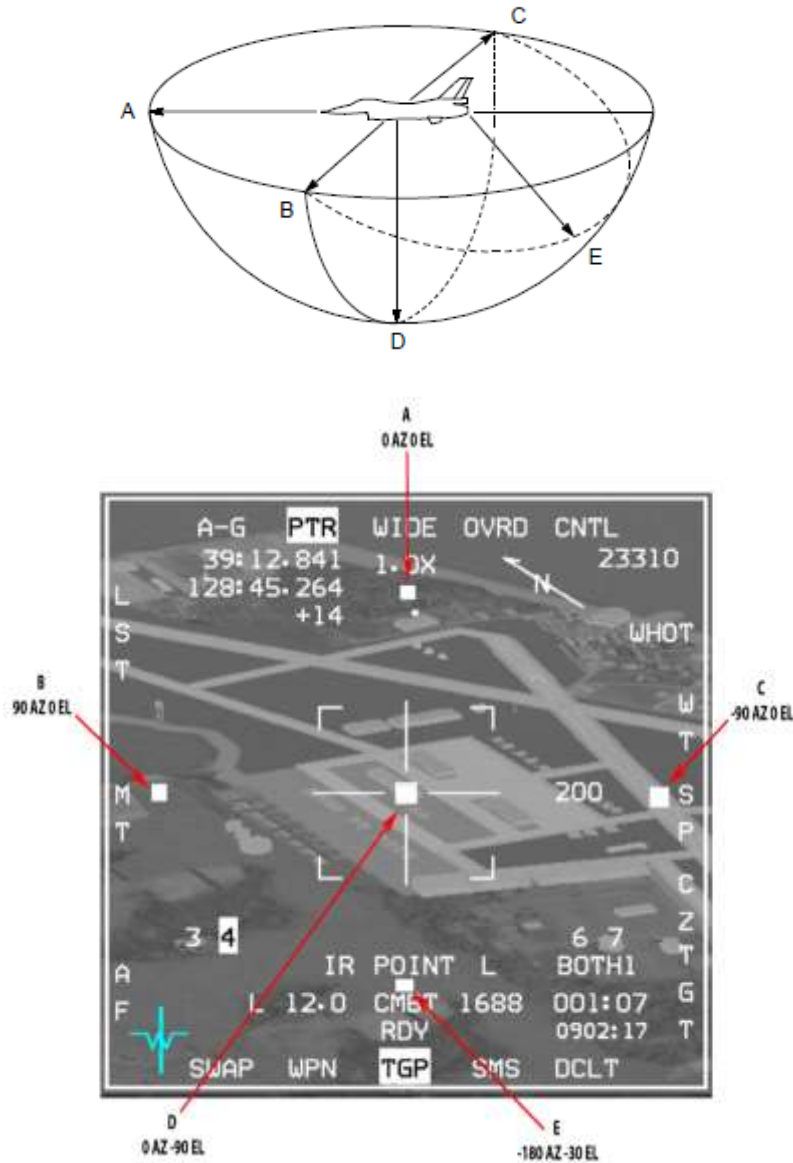

Figure 80 Situational Awareness Indicator

1.10.9.2 Attitude Advisory Function (AAF)

If the TGP is in A-G mode, TGP format is displayed and the aircraft exceeds any of these defined attitudes:

- a) Bank > 75°; Pitch < 0°.
- b) Pitch < -20°

A flashing red rectangular box with a double set of words CHECK ATTITUDE is displayed on both MFDs (all formats).



Figure 81 CHECK ATTITUDE on MFD

1.10.9.3 Radar Altitude Symbology

Radar altitude symbology is displayed in the upper right corner of the video display. Radar altitude is displayed whenever the pod is in A-A or A-G mode and the radar altitude received from CARA is valid.

1.10.9.4 Menu

Pressing OSB 2 in the Sniper Control page will bring up the Menu. Currently the Menu supports 2 functions: Frag circle and IR pointer pattern selection.

- Frag circle – The frag circle is a circle displayed in a selected radius around the TGP position. The radius of the circle and the option to display the circle are defined inside the menu.
- IR Pointer pattern ID – IDs 1-4 are available for the IR pointer pattern. Selection of an option will command the IR pointer to fire the IR beam in a different pattern.

Navigating in the menu is performed as follows:

- TMS-Up – Select/change an option that is currently pointed by the menu selection arrow.
- TMS-Right – Move the menu selection arrow 1 step down.
- TMS-Left – Move the menu selection arrow 1 step up.

1.10.10 Additional Notes

Sharing Between Players - Laser and IR Pointer spots are shared between players. When a player is lasing or firing the IR Pointer, a MP message is sent every 0.5 second and shared by all players.

LGB Code - LGBs use a pre-set laser code and can guide only on laser energy which is of the same code. The laser code for the LGBs is set at the UI munitions screen in the SET CODE field. Once applied the code is programmed into all the LGBs mounted on the aircraft and cannot be changed while airborne.

Buddy Lasing - Buddy lasing can be done by simply dropping LGBs in the vicinity (LGB basket) of a laser spot being fired from another human pilot's laser (AI or ground troops lasing isn't implemented) which matches the laser code of the LGB. If the bomb finds a spot and tracks on it then it'll keep guiding towards that spot unless the spot is lost and then the bomb will look for a different spot. If at the dropping moment more than one spot is detected, the bomb might guide on any of the spots.

Laser Ranging - In order to know if your laser fire is valid you can fire and check if you see valid ranging (L will appear next to the range on the Sniper page). None valid ranging mean that the fired laser doesn't have enough energy to illuminate the spot; that can happen because of range (the laser has limited range) or weather (clouds obscuring the LOS). In such cases the fired laser can't be used to guide LGBs or be tracked by LST.

LGB LOS - LGBs will not guide on laser spot if the LOS between the bomb and the spot is masked by clouds.

Training And Combat Laser - When guiding LGBs or firing a laser that should be detected by LST, make sure to use the Combat laser mode as the Training laser isn't for operational usage and has much lower energy output.

IR Pointer - IR Pointer fire validity also depends on range and LOS. The energy on the spot will be seen as a flashing bright dot when NVGs are used (and on the TGP page). There are 4 patterns of IR Pointer flashing, selectable from the TGP MENU page (OSB 5 CNTL then OSB 2 MENU).

Time to Steerpoint/Release/Impact: Time to steerpoint, release, or impact is displayed in the lower right corner of the TGP page depending on the master mode and whether a weapon has been released. In NAV master mode, this display indicates time to steerpoint. In A-G master mode, this display indicates time to weapon release; then displays the estimated time until impact.

1.10.11 Operational Considerations

With the above knowledge in your hip pocket, you can begin to learn how to use the enhanced capabilities of this new targeting pod. It will take some practice to get used to the system and its quirks and to become proficient. The following should get you started off in the right direction. First, we'll look at air-to-ground operations.

1.10.11.1 *Air-to-Ground*

We'll start off with a typical scenario that you the pilot have started off in Taxi or Takeoff mode. All of your systems are up and running, including the TGP. This means you will not have to wait for the system to cool down before you can use it as would be the case if you did a Ramp start.

You are safely airborne and on your way to your target. The first thing you will want to do is call up Air-to-Ground (AG) mastermode (mm). On your left MFD, you probably have the AG GM radar up and sweeping. On your right MFD, you will want to call up the TGP base page. If you have the WPN page in one of the MFD slots and don't have any weapons that require its use (e.g., Mavericks), then replace that page with the TGP base page (I typically run with HSD, SMS and TGP as my set up on the right MFD). Hit the OSB (option selection button) under "WPN" to switch to that page (if you're not already on it), then hit that same OSB again to switch to the main MFD menu. Hit the OSB next to "TGP". You should now see the TGP is STBY mode, waiting for you to select the operating mode. Next, hit OSB 1 (upper left) above "STBY". Next select the OSB next to "A-G" (OSB #6). That commands AG mode for the TGP. At this point the TGP page may still be blanked. If it is, select Master Arm on (if you're actually getting ready to attack or just want to arm the laser) and that will bring the video to life. *NOTE: At this point in time, to arm the Laser, you must be in Master Arm on. So, arm up the laser.* If you're not going to be attacking a target, select Master Arm Simulate.

From here, you will want to decide what FCR radar mode and submode you will need to use which is dependent upon your target. Are you hitting a building or looking for a column of tanks? Is the building at a steerpoint of mine? Is the column moving or holding their position? Does the target(s) require continuous lasing or can I use delayed/automatic lasing? All of these are questions you should think about while you are still planning your mission so you will know prior to getting to the target what modes you will need to call up. We'll run through two examples.

1.10.11.2 **Scenario 1 – Fixed Target, One Pass**

In the first example, we will be hitting a nuclear plant with 2 GBU-10s rippled in pairs from 22,000 ft and we have precise lat/longs for the target entered into our STPT 5. We have our LASR page set to start automatically lasing the target 20 seconds prior to impact. We will want to leave our radar in GM mode with STP/TGT (steerpoint/target) mode selected. That will allow our GM radar to point/aim at the selected steerpoint when we switch to it making it easy to find our target. We're 20 NM from the target and we've acquired the plant on the radar. We've locked it up in GM STT. Next, DMS (display management switch) down/aft to get the sensor of interest (the big box on the outside of the MFD) on the TGP MFD.

With the SOI box on the TGP page, TMS forward (or TMS right) to ground stabilize the TGP in AREA track. You should see the target and now can refine your slew to the target you desire to hit. Select Master Arm on, make sure the laser is armed and ensure you've got the proper munitions selected that you're going to drop on the target. Follow the normal delivery cues as necessary and drop the munitions. Be careful not to manoeuvre too aggressively and mask the target or make the TGP go into RATES tracking. If it does, you will have to refine your slew again. A good technique is to make a gentle turn away from the target toward your egress direction to keep it more off to the side rather than underneath your jet. But there shouldn't be a problem with over flying the target either if that is what is required. You're eyeballing your TGP while also looking outside clearing for threats. Thirty seconds prior to impact your laser should fire and provide terminal guidance to the bomb. Impact. You can now TMS down to break AREA track and command the TGP to the FCR line-of-sight (LOS). You can exit AG mm and egress.

1.10.11.3 **Scenario 2 – Moving Targets, Multiple Passes**

In this example, our target is a column of T-62 tanks that are rapidly moving south and we need to stop them. Our loadout is 4 GBU-12 which we will be dropping in singles. We've positioned our TGT STP 5 around in the vicinity of where we expect the column to be when we arrive on target but we've kept in the back of our mind that they may not be there.

After safely airborne and enroute to the target, we begin the administrative tasks of checking our systems out in AG mm. Again we call up the TGP base page and select A-G mode of operation. This time, we've planned to initially use STP/TGT submode in the GMT mode. Thirty to 25 miles out we begin looking for movers at our STPT 5—nothing so far. Ten miles from the STPT we pick up some movers 5 miles to the north of our STPT. Since there are no friendlies around for miles, we know this is our target. They appear to be heading toward our STPT. We switch into SP (Snowplow) mode in GMT. This mode is better suited for looking for our targets not at our steerpoint. With the SOI on the GM scope, we TMS forward to enable us to slew the radar cursors around. We slew over to the movers and lock one up. Next we DMS down to switch the SOI to the TGP. Next, command TMS forward to stabilize the TGP and enable slewing. We use the pinky switch to change the field of view (FOV) to EXP so we can get a good visual. At last we see some tanks moving. We slew over to one of them, cease slewing, and then TMS forward and command POINT track. We begin a shallow dive and release. We manually lase the mover with our trigger to ensure the bomb will hit. Shack!

NOTE: It is important to cease slewing before commanding a POINT track or the cursors will "jump" off the target as you're trying to lock up the mover. You can practice this and see exactly what happens. It is also important NOT to

make any slew inputs while in POINT track as it will also make the cursors jump off and away of what you were tracking, unless you are intentionally wanting to break POINT track. The cursors jumping off is a bug. As you can guess, this can make getting a POINT track on a mover a challenge. It is best to lead the mover and let him drive into your cursors and then command POINT track. Also note that you may likely need to be in narrow or expanded FOV to get a POINT track, as the size of the object is important in if the TGP can get a track on it. Also if you are too far away, POINT track may not be able to get a lock. Aggressive maneuvers or a MASK condition can break a POINT track.

We plan to conduct multiple passes until all of our bombs are off. This can be accomplished a couple of ways. After the first pass, we can leave our TGP in AREA track and make small slews to follow the column as they move and as we reposition for another attack. You can also choose to TMS down and command the TGP to slave to the GM FCR LOS. Either works and depending on the situation, you may want to use one over the other. If you TMS down, the TGP will be slaved to the radar and you will have to conduct another search similar to how you set up the first pass. Another thing you can do (on the first or another pass) is after slewing the radar cursors to the column, since you don't have a STPT at that exact location, you can hit 7 (MARK) on the ICP and then SEQ Right until you get to "FCR", then hit ENTR to take a mark point on where the column is. Then you can switch to that markpoint (#26) with M-SEL and press CZ to zero out the cursor slews, to aid in navigation and delivery, or you can just use it as a reference on the HSD as to where the column is. Realize if they're moving, they may not be in the same place as the Mark. Take that into consideration for your aiming and even take another Mark point if desired on another pass. Another important consideration is to ensure you give yourself enough time and spacing to conduct another pass without having to rush it or make a sloppy delivery. This may mean getting as far away as 10 miles (or more) before turning back into the target. With practice, experience and know-how, you can narrow this distance down and stay closer to the target between each pass. But initially, you should give yourself plenty of time to work the sensors for each pass, otherwise you'll wind up off dry and what did you accomplish? Nothing except a miss, a dry pass, or just burned more of your gas down—not to mention maybe even got shot at unnecessarily. Pacing and patience is important as you're learning this new system. There are many methods, techniques and procedures that one can do to effectively employ this new system. Practice is the biggest key and trying new ways in training missions can pay off in learning new or better ways to employ.

1.10.11.4 Air-to-Air

The TGP can be a great asset in the A-A role. Its advanced optics and IR capabilities can see much farther than the Mark I eyeball, making it an excellent ID tool for BVR or near-BVR ranges. As stated above, it can be slaved to the radar or also work independently of it, just like in A-G. This allows the pilot the ability to monitor or track a target with the TGP, but use his FCR to continue searching or tracking other targets. The pilot can set the TGP in one of the MFD page slots in MSL OVRD, DGFT and/or NAV modes and switch the SOI to the TGP to command expanded FOVs for ID purposes. Take the following example: The pilot bugs a contact at 10NM on the radar. The A-A mode of the TGP is called up and the pilot sees the target as the TGP is slaved to the radar. Switching the SOI to the TGP and commanding expanded FOV to get a better picture of the target, the pilot then TMS forwards to command a POINT track on the target. Recall that just like in A-G modes, POINT tracks on targets far away may not be possible. If the TGP drops a POINT track, a TMS down *with* the SOI on the TGP may be necessary to re-slave the TGP to the FCR. Remember, display polarity selection is also available. At range, the TGP may display a better picture in WHOT compared to TV mode, for example. With the SOI on the TGP, TMS left will cycle display polarity options (WHOT – BHOT – TV) or OSB 6 may also be pressed to cycle it. Using the TGP effectively in combat takes switchology practice to gain proficiency, but once learned can be a valuable tool.

1.11 HELMET MOUNTED CUEING SYSTEM (HMCS)

The Helmet Mounted Cueing System (HMCS) is an Electro-Optical (E-O) device that serves as an extension of the HUD by displaying weapon, sensor, and flight information to the pilot. Combined with high off-boresight missiles, the system gives first look, first shot, first kill capability in the visual arena.

The HMCS is only available in aircraft in the database that have the “Has HMS” flag option selected. The HMCS is controlled via HMCS symbology rheostat (OFF/ON & brightness control) in the 3d pit or with the [] keystrokes.

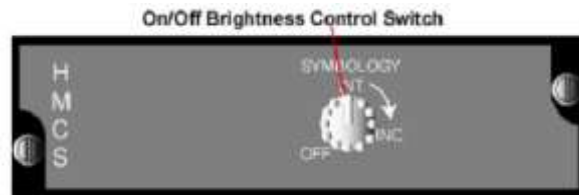

Figure 82 On/Off Brightness Control Switch

The HMCS is basically an extension of the HUD, and as such the HUD and HMCS are considered as one SOI (i.e. they share the same hands-on-control switchology). The HMCS FOV is defined as a 20° diameter circle centred on the HMCS LOS. Wherever the pilot looks within the HMCS field-of-regard (FOR), appropriate symbols from the aircraft are accurately displayed, based on the current HMCS LOS.

The HMCS performs different functions:

1. Off boresight slaving of FCR in the A-A Mode
2. Off boresight slaving of AIM-9 missiles
3. Ownship performance information and status

1.11.1 Control Pages

The HMCS has two DED control pages. The first is accessed by pressing LIST→0. The second can be accessed by pressing SEQ on the ICP. The first allows HUD and cockpit blanking, which allows the HMCS to turn off with the pilot looks either towards the HUD or down in the cockpit. The HMCS and HUD share many symbols, which tend to visually conflict with one another when looking through the HUD and an HMCS. Forward (HUD) blanking is a display declutter feature that removes all HMCS symbols (in A-A or A-G mode) when the HMCS LOS (borecross) is within the inside edge of the HUD instantaneous FOV. The HUD blanking region applies when the difference between the HMCS LOS and the CTFOV of the HUD is less than +10° in azimuth and +10° in elevation.

1.11.1.1 HUD Blanking

The HUD blanking feature is controlled from the DED HMCS DISPLAY page by placing the asterisks around HUD BLNK and depressing M-SEL on the ICP. When mode selected, HUD BLNK highlights and remains highlighted until deselected and the asterisks auto step to cockpit blanking (CKPT BLNK). HUD blanking is deselected by placing the asterisks around the highlighted HUD BLNK and depressing M-SEL. Invoking HUD BLNK has no impact on the ability to slave missiles to the HMCS LOS.

1.11.1.2 Cockpit Blanking

The cockpit blanking (CKPT BLNK) feature is a selectable display declutter feature that removes all HMCS symbols except the missile diamond, steerpoint diamond, aiming cross, ACM bore symbol, and TD box from the display when the HMCS LOS is below the cockpit canopy rails. The HMCS aiming cross, target locator line, and TD box will stay displayed on the HMCS when cockpit blanking is enabled and the HMCS LOS is in the cockpit blanking region. Cockpit blanking reduces eye clutter when performing head-down (in-cockpit) tasks. Cockpit blanking is controlled in a manner similar to HUD blanking.

1.11.1.3 Declutter

The HMCS has 3 levels of declutter available. To rotary through the levels, position the asterisks around DECLUTTER and depress any key 1-9. LVL1 is the lowest declutter state and declutters nothing. LVL2 declutters the following: altitude, range to steerpoint, and helmet heading scale. LVL3 declutters the following: altitude, range to steerpoint, helmet heading scale, airspeed, normal acceleration, and ARM status window.



Figure 83 Level 1 / Level 2 / Level 3

1.11.2 Hands-On HMCS Blanking

The display management switch (DMS) enables and disables HMCS display. A DMS-aft and hold for ≥ 0.5 seconds toggles the HMCS between displaying symbology and not displaying symbology. This feature is independent of the HUD or CKPT blanking states. Hands-on-control blanking overrides all other blanking including the HUD blanking feature and cockpit blanking feature until the HMCS display is redisplayed via a second DMS-aft for ≥ 0.5 seconds. When the symbology is being blanked, the system behaves as if a helmet is not in the avionic system and returns to baseline ACM operation and baseline missile bore operation.

1.11.3 HMCS Dynamic Aiming Cross

The HMCS dynamic aiming cross is designed to allow the pilot to more easily slave weapons to the HMCS LOS during high G, high look-up angle conditions. The cross moves linearly in elevation only from the centre of the HMCS FOV to plus 168-mR head elevation changes from +30 degrees to +80 degrees.

1.11.4 Air-to-Air Operations

The HMCS A-A mechanization provides the capability to slave the AIM-9 A-A missiles to the HMCS aiming cross LOS when the missile is in the BORE LOS mode. In addition, when the FCR is placed in ACM BORE, the FCR is commanded to the HMCS LOS if ACM BORE mode is selected and the FCR is SOI.

The HMCS populates its windows with data and position symbols based on the same conditions and requirements for displaying data and symbols on the HUD.

1.11.4.1 AIM-9 Missile BORE Operation

When an AIM-9 missile is selected with HMCS and the missile LOS is BORE (cursor-z depression), the avionic system slaves the missile LOS to the HMCS aiming cross LOS. Note that when the AIM-9 missile is uncaged, the enlarged missile diamond is displayed on the HMCS. If HMCS is not on, the missile diamond is displayed only on the HUD.

When SLAVE is selected with a TOI, the avionic system slaves the missile to the FCR LOS and the missile diamond is displayed at the FCR LOS on the HMCS. With SLAVE selected and no TOI, the missile seeker points three degrees down from the HUD bore cross.

Note: The missile diamond will be displayed in the centre of the HMCS up to 28° from boresight. Beyond 28°, the missile diamond will move from the centre of the display until it reaches the edge of the HMCS display. Upon reaching this point, an X is displayed over the missile diamond.

1.11.4.2 Slaving FCR ACM BORE without a TOI (FCR Not Locked On)

When ACM BORE is selected and TMS-forward is held, the radar is slaved to the HMCS aiming cross LOS in a non-radiating state. The FCR ACM BORE ellipse is displayed on the HMCS at the FCR LOS. The radar is commanded to radiate when TMS-forward is released. The radar automatically attempts to acquire a target in the ACM BORE ellipse when TMS-forward is released. Note that if the HMCS LOS is moved past the FCR gimbal limits, the avionic system continues to try to slave the FCR LOS to the HMCS LOS even though the FCR gimbal limits have been reached. In this case, the FCR ACM BORE ellipse remains displayed over the HMCS aiming cross, even though the FCR is at its limit and can no longer attain the actual HMCS LOS.

1.11.4.3 Slaving FCR ACM BORE with a TOI (FCR Locked On)

If there is a valid TOI upon entry into ACM, the avionic system controls the ACM submodes per baseline.

1.11.4.4 BORE/SLAVE Toggle

Changing the BORE/SLAVE option on the SMS base page for either the AIM-9 or AIM-120 will simultaneously change BORE/SLAVE status for both missile types (master mode dependent). The cursor-z axis can also be used to change to the opposite state as long as the switch is held. Upon release of the cursor-z axis, the state returns to the original state ("dead-man" function). The HMCS will indicate SRM-S or MRM-S for SLAVE, and SRM-V or MRM-V for Visual BORE.

2 AIR-TO-AIR-COMBAT

2.1 WHEN SHOULD YOU CHUCK YOUR SPEARS?

Reproduced from the *AMRAAM Pilot Guide* article on bmsforum.org, originally published on March 13th, 2010.

The goal when you shoot an AIM-120 is to be able to preserve range while maintaining the highest probability of kill. To do so, you will have to use all the tools at your disposal and a bit of sound logic! When talking about tools, I'm referring to the AMRAAM Dynamic Launch Zone (DLZ) and the Head-Up Display (HUD) symbology modelled in BMS, which is simulating current F-16 software.

2.1.1 A Bit of Theory

Before going into details about the avionics itself and the tactics to be employed I'll give you first some theory about the AMRAAM and active missiles in general.

The AMRAAM is an **active** missile which is considered to be "fire and forget". That's not exactly true. The AIM-120 has its own radar but this one is much smaller than the one of the launching aircraft. So the range at which the missile will be able to detect and lock a target will be smaller than the radar detection range of the aircraft. However, the missile can be launched from further away than its detection range. In this case, the launching aircraft will have to send information to the AMRAAM via datalink (or **support** the missile) about the target position, aspect angle and speed until its own radar is able to detect it by itself (missile becoming finally active). Once the missile is active, you will be able to break track of the target (which is called a 'snip') however that's not mandatory! Why continue to support the missile if it's active? Accuracy when having 2 radars is always better than one!

The AIM-120 has 2 active states: **HPRF** (High Pulse Repetition Frequency) and **MPRF** (Medium Pulse Repetition Frequency). I won't go into details about these right here (it is described below) but only know that HPRF will be used from further away than MPRF and is less accurate concerning the information about the target location. Anyway, you can snip the target as soon as the missile is HPRF active or choose to continue until MPRF active. This choice will depend on the tactical situation and will be discussed later on.

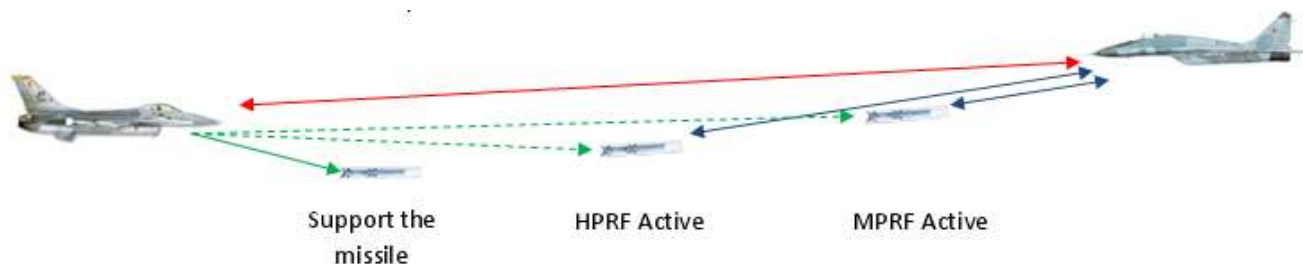

When launching an AIM-120, this missile can end up with 2 different **termination criteria**. What are termination criteria? It describes the kinetic energy and the manoeuvrability potential the missile has to successfully intercept the target and destroy/damage it. It can have **High Termination Criteria** or **Nominal Termination Criteria**. The latter means the missile will have less energy and manoeuvrability thus less probability to hit the target.

Sometimes, you will have to **loft** the missile to increase its effectiveness. Lofting will be done via a small pitch up manoeuvre of generally 30 to 40°, just like throwing a stone as far as possible.

2.1.2 AIM-120 modes of operation

The AIM-120 can be operated in 2 modes: SLAV and BORE. Switching between the two modes can be done either on the SMS page, or with the CURSOR/ENABLE button. CURSOR/ENABLE can switch between SLAV and BORE either momentarily for as long as it is pressed, or as a toggle, depending on the particular aircraft avionics.

SLAVE mode: SLAV is the standard mode of operation for the AIM-120. In SLAV mode, the missile is slaved to the FCR. When a track is bugged on the FCR (SAM, TTS/DTT or STT), the missile will be fired at the bugged track. As long as the target remains bugged on the FCR, the missile will receive updates on target position in-flight via the AIM-120 datalink up to the point when it is close enough to activate its own seeker. With a bugged target in SLAV, the missile can be fired with a long press of the Pickle button.

SLAV mode without a bugged target: A missile can be fired in SLAV without a bugged target, by a long simultaneous press of UNCAGE and Pickle. The missile is then fired without a target and will not activate its seeker. This mode is essentially a missile jettison.

BORE mode: BORE allows you to fire a missile relying solely on the missile seeker to find a target. In BORE launch, the missile seeker goes active directly after launch and targets the first aircraft it 'sees'. This mode should only be used for self-defence with extreme caution, as the missile seeker will not discriminate friend or foe (the brevity for such a launch is MADDOG for good reason). In BORE mode, missile fire is done by a simultaneous long press of UNCAGE and Pickle. In BORE mode, the missile will ignore any bugged target on the FCR.

2.1.3 HUD Symbology: The Dynamic Launch Zone (DLZ)

What does it look like and what's the use of all these numbers and symbols?

R_{AERO} (Range Aerodynamic): Represents the max kinematic range of the missile, thus the longest range shot having a chance to hit the target. This is assuming the target doesn't manoeuvre, the pilot performs optimal loft/steering and the missile will result in Nominal Termination Criteria.

R_{OPT} (Range Optimal): Basically the same as R_{AERO} but with High Termination Criteria this time.

R_{PI} (Range Probability of Intercept): Same as R_{OPT} but without having to loft or make azimuth changes. We still assume the target is non-maneuvering.

R_{TR} (Range Turn and Run): Represents the max range shot, assuming the target turns away from your aircraft to tail aspect at launch.

R_{MIN} (Range Minimum): Self-explanatory!

A-POLE: Range from your aircraft to the target when the missile will go active (HPRF).

M-POLE: Same as A-POLE but MPRF active.

F-POLE: Range from your aircraft to the target when the missile will impact the target.

DMC (Digital Maneuvering Cue): Represents the heading change the target has to make to degrade the AMRAAM from high termination criteria to nominal. This value will never exceed the AA (Aspect Angle) and the R_{TR} cue will grow up to this value.

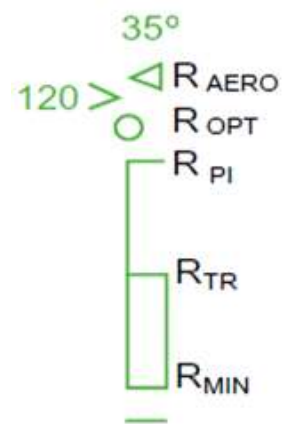

For example:

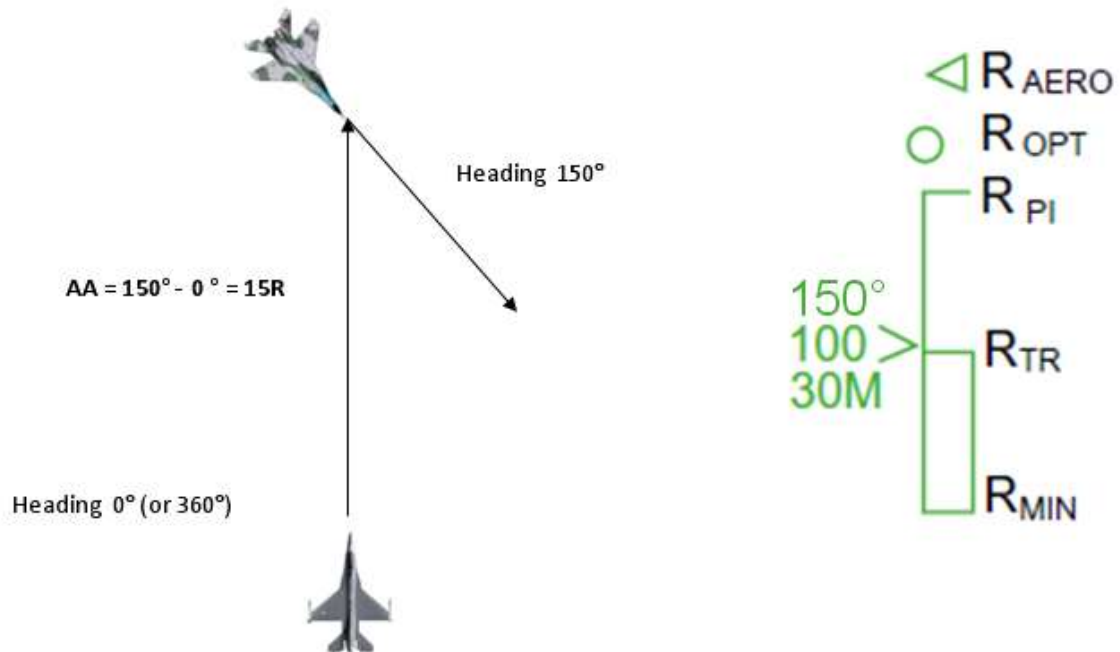

Let's see all the possibilities we can encounter in flight:

- When the target is beyond 125% of R_{AERO} (unexpanded DLZ)

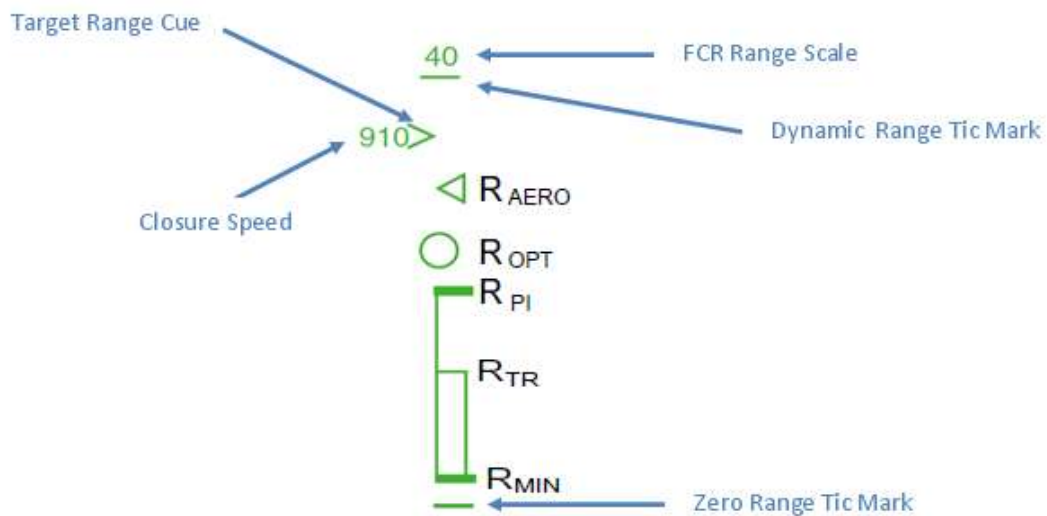

- When the target is within 125% of R_{AERO} (expanded DLZ : R_{AERO} grows up to the former tick mark)

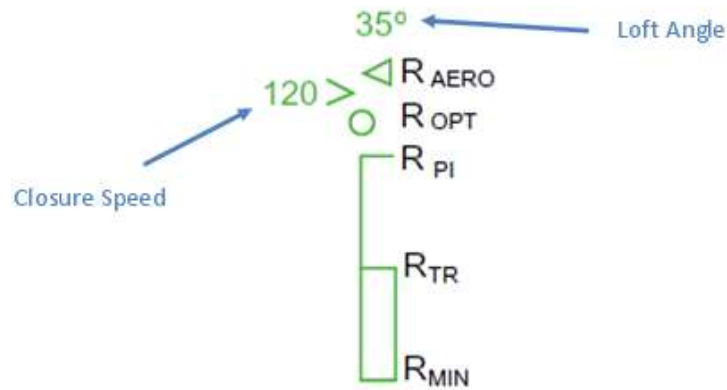

- When the target is within R_{OPT}

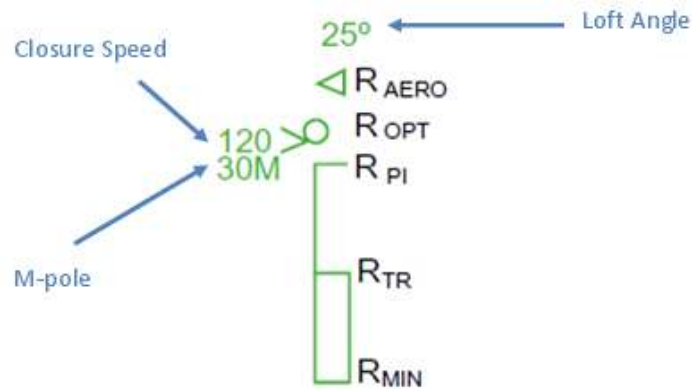

- When the target is within high termination criteria of the AMRAAM (R_{PI})

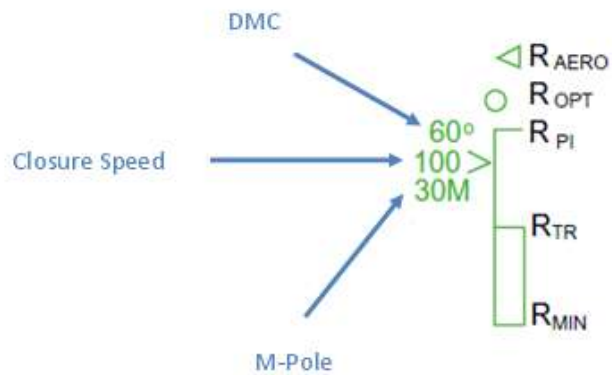

- When the target is within the no-escape zone of the AMRAAM (R_{TR})

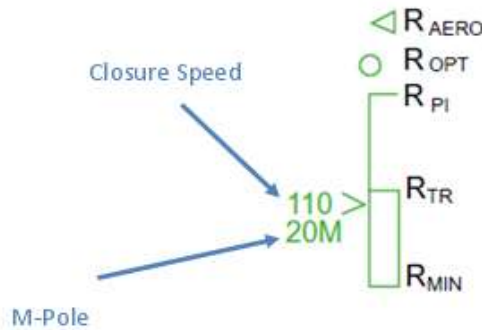

Once you've launched a missile, the M-pole or F-pole of the missile in-flight (depending if the missile is already MPRF active or not) as well as the Time to HPRF active or Time to MPRF active or Time to Impact will appear below the DLZ. This is a dynamic countdown that will be updated if the target or your aircraft maneuvers. Consider a shot taken at R_{OPT} then you fly straight ahead to the (maneuvering) target.

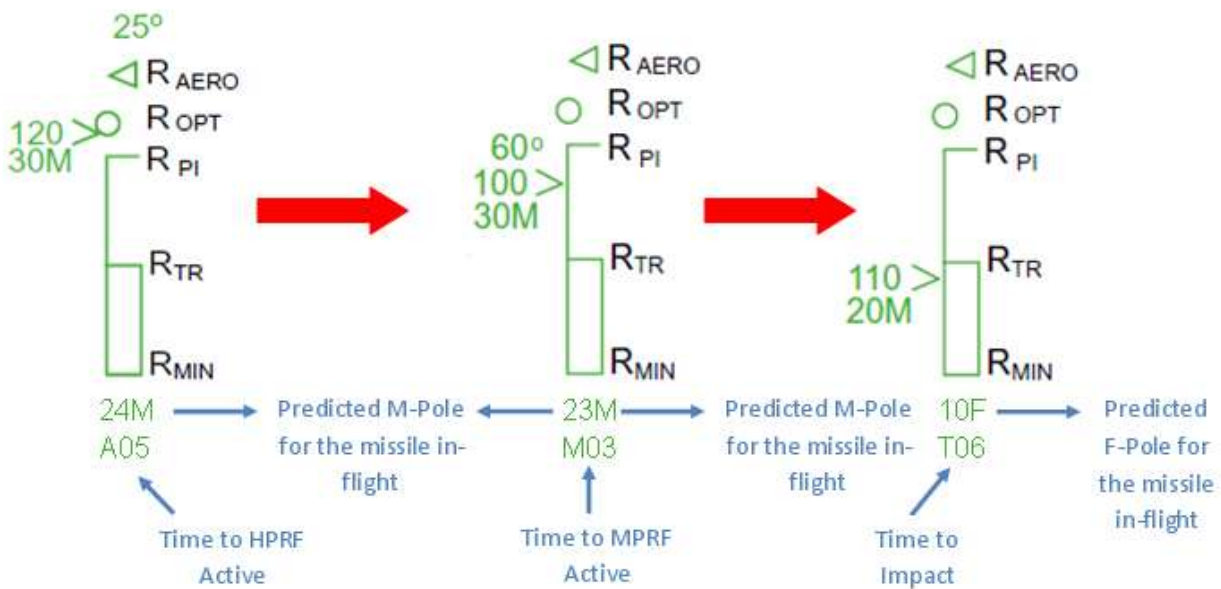

2.1.4 HUD Symbology: ASEC/ASC

Allowable Steering Error Circle (ASEC) – The ASEC is a variable diameter circle displayed on the HUD and MFD when an AIM-120 is the selected weapon, sighting option is Slave, and a bugged target exists. The weapon status must be RDY or SIM (Master ARM in ARM or SIM) in order for the ASEC/ASC and DLZ to appear. If there is no bugged target, the AIM-120 Boresight reticle will be displayed. The ASEC is an aid for positioning the attack steering cue in order to take the best shot possible based on the steering. At target ranges from outside R_{aero} to R_{opt} , the ASEC is its smallest size, 11mr radius. At R_{opt} , the ASEC begins to grow in size until target range reaches R_{pi} where it reaches its maximum size (the ASEC represents 45° of allowable steering error at R_{pi}). From R_{pi} to midpoint R_{tr} , the ASEC remains its largest size, at which point it begins to shrink again until it reaches minimum size at R_{min} . The ASEC flashes when the target range is within the manoeuvre zone. The ASEC's variable radius varies from 11mr to 56mr with a slaved target. For a bore shot, the radius is static at 131mr (262mr diameter). The ASEC on the MFD is identical in function.

Attack Steering Cue (ASC) – The ASC (8 mr diameter circle in the HUD, 10 pixel radius circle on the MFD) provides several types of steering: horizontal aircraft steering, a blend of aircraft and missile steering, optimal missile steering (with horizontal and vertical missile steering), or Rmin steering (shortest LOS to the target). The type of steering provided is a function of range to the target. Horizontal aircraft steering is provided against targets beyond $1.2 \times R_{aero}$ (where R_{aero} is the maximum kinematic range of the missile) and is based on the limits of the ASEC and a 45 degree LOS to target limit. Blended aircraft and missile steering is provided for target ranges between $1.2 R_{aero}$ and R_{aero} . Inside R_{aero} , the steering provides optimal horizontal and vertical missile steering. Once inside mid-point R_{tr} (half-way in the manoeuvre zone), the ASC provides Rmin steering. The pilot follows the ASC cue by rolling until the cue is on the HUD centreline above the centre position of the ASEC and then pulls the aircraft (if commanded) to put the ASC in the centre of the ASEC. When the target range is greater than R_{aero} , a limit cross (X) is displayed inside the ASC to indicate that an AIM-120 shot does not exist even if the pilot performed a loft manoeuvre. The limit cross will also be displayed when the required lead angle exceeds 60° , even if the target is nominally in range. Neither the ASEC nor ASC are displayed on the HUD in DGFT mode.

The following diagram sums ASC/ASEC relationship to the DLZ and the type of steering provided:

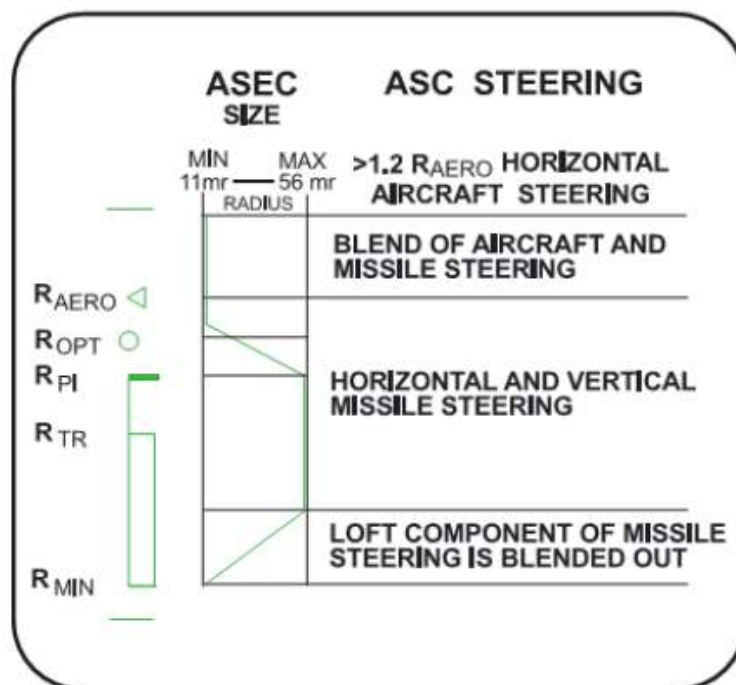

2.1.5 HPRF vs. MPRF, A/F-pole cues and Missile Datalink

This version of BMS features a major revision of the AMRAAM DLZ A/F-pole cues and associated range and timing readouts. HUD, HMS and FCR displays now all include updated A/F pole cues. In addition, the AMRAAM loft cue was moved (look above R_{aero} caret) to make room for the new Digital Manoeuvring Cue (DMC) (shown above the target closure value by the range indicator >). The radar model for AMRAAMs now includes HPRF (Husky) mode for favourable target geometries. The missile will activate the seeker well before the normal MPRF (Pitbull) range and attempt to track. HPRF is better at tracking high aspect targets with high closing range rate. Datalink guidance will continue up to MPRF unless the pilot commands a snip (drops the radar track) before that time. During HPRF with host (aircraft) DL guidance, the missile will use the best tracking solution available (either seeker or host DL guidance). HPRF and MPRF activation are now entirely based on range to target (it used to be time-to-run based).

Note well: Flight models were comprehensively updated in 4.33 for many missiles, including the AIM-120B and AIM-120C, which now have very different characteristics. Experienced pilots will notice many missiles behave more realistically now. As a result the DLZ can be relied upon as a much more accurate trigger for offensive and defensive maneuvers; previously you often needed the target deep in the No Escape (Rtr) region in order to kill it. In simple terms, if you shot at Rpi the missile loss of energy at end game allowed targets to be head-on when the missile went active (Pitbull), turn away, accelerate while going low, out drag the missile for a good 30s and come out of it alive.

This also meant that Minimum Abort Ranges (see below) were not really critical and you could usually overshoot MAR without sweating too much. Hopefully, with the new missiles, this won't happen and Minimum Abort Range will be critical again.

The pilot can now select the RCS size on the AMRAAM's SMS page. Options are small, medium, large or unknown. Note: you can select SMALL in the SMS page but doing so doesn't make a lot of sense in Falcon 4 since this is apparently intended for targeting small RCS targets although it might be useful against helicopters. If you do choose small, MPRF ranges are reduced by around a third compared to MED.

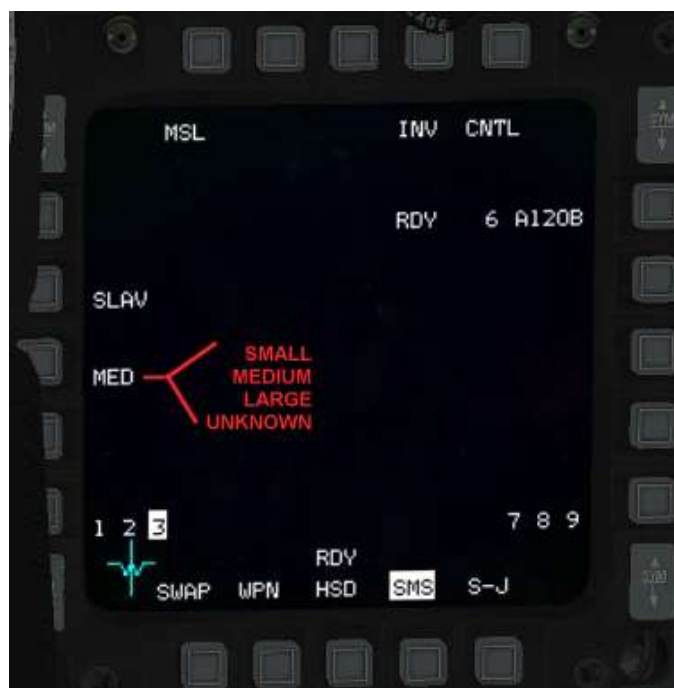

HUD A/F pole cues are provided for pre-launch and post-launch. Post-launch cues are relative to winning Missile-Of-Interest (MOI) for the current bugged target. Changing the bug in TTS or TWS will provide A/F pole cues for the MOI for each if missiles are in flight to both. Time remaining cues are provided for the MOI for the current bugged target. This can show "A" (time to HPRF), "M" (time to MPRF), "T" (time to intercept) or "L" (time to termination; basically missile time of flight remaining). Note that this timer is more persistent than before. It's dynamic for bugged target and a winning MOI. For a winning missile where you lost track or snipped, the count becomes a simple stop watch. One note of caution: it's not a bug that the timer doesn't count down in linear fashion for a bugged target with an active DL missile. The time to intercept is calculated dynamically and takes target manoeuvre into account so it's perfectly reasonable for that count to increase even in some cases.

Missile datalink has been fixed to allow you to support up to six missiles in flight. AMRAAMs may be fired on up to two targets (TTS) or up to six targets (TWS). You can get A/F pole and time remaining data for all six missiles if you have six in flight and provided that their intended targets are still present on the FCR as track files.

There is also a bug fix for bogus clearing of target when you flip between override modes or SMS changes from one missile type to another while you have a bugged target – now the lock is maintained. There is also a fix for datalink – previously last slammer was never provided with any datalink guidance making it significantly worse in performance compared to a missile fired with more of the same (slammer) type left on the rail.

2.1.6 Tactics - Some Basics

This section is not intended to go into a full BVR employment discussion, but at least provide you with some very basics on how to tactically apply the tools you learned above. Let's see what you can do to maximize the probability of kill while staying alive! Let's play it safe by learning first how to survive the threat. For this purpose we'll take as example a Mig-29A playing the threat equipped with AA-10A missiles. Let's assume the maximum kinematic range of this missile while launched around 25,000 ft and subsonic is around 18 NM against a head-on fighter. Less aspect angle will subsequently decrease the first launch opportunity (FLO). To survive this missile launch, the simplest solution is simply to avoid this max kinematic range by turning away from the MiG.

Does it mean that you have to turn @ 18 NM from the MiG? No! The kinematic range takes into account that the fighter will continue straight ahead until missile impact. So the distance the missile will have to fly will be less than 18 NM. Actually, if you turn away from the MiG at or beyond 13 NM, the missile will never catch you and will fall behind you. This distance at which you have to turn cold (13 NM in this example) is called MAR - Minimum Abort Range.

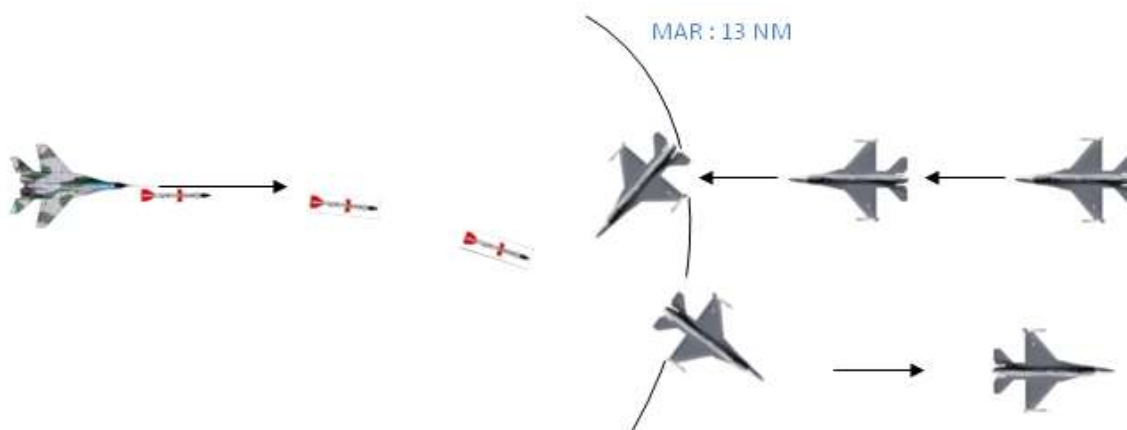

The way you have to **abort** is simple: you obviously want to avoid being hit by the missile so put your nose down and try to keep the maximum speed you can while turning away from the threat as fast as you can. A split-S manoeuvre can also work, but there could be consequences for trading too much altitude for airspeed (for example you may not want to do this if there is a MANPAD threat at lower altitudes). Anyway, watch your G's and don't over-g your aircraft! G's should be around 5 to 6. This will give you a good turn rate while preserving some speed.

Still alive? OK then we continue! From the theory we learned, we know that the maximum probability of kill of the AMRAAM happens when it's launched as close as possible from RTR (or even within RTR) and when the missile is MPRF active. The goal will then be to have an AMRAAM in flight MPRF active before 13 NM as we will abort at that range if we are spiked or shot at. How do we do that? We will look to the Pre-launch M-pole displayed on the left of the DLZ when inside R_{OPT} and shoot not later than 13M! When approaching 13 NM from the MiG, the Time to MPRF Active should read M00 meaning the missile is MPRF active. So you can **snip** the target (break radar lock) and perform the abort.

Happy Chucking!

3 AIR-TO-GROUND

3.1 SPI MANAGEMENT

3.1.1 Introduction

In order to improve air-to-ground (A-G) experience in Falcon BMS, a little more accurate behaviour and interaction of the main A-G sensors has been implemented. SPI is a key factor in the A-G environment and it is very important to understand how it works. The purpose of this section is to introduce SPI management and its interaction with the main A-G sensors.

Please note that this section isn't an entire overview of the relevant sensors and it doesn't come as a replacement for reading the more detailed explanations about each sensor.

3.1.2 SPI Description

SPI – System Point of Interest, as its name implies, is the point on the ground where (usually) the A-G system is concentrated. The SPI position can be determined (or controlled) by 2 sensors:

- FCR in GM/GMT/SEA while in STP mode.
- Targeting Pod.

Each of these sensors can slave the SPI to where it is pointing according to the avionics and the sensor's mode. The SPI position is then shared between those sensors if conditions fit.

When one of the above sensors is in tracking state (i.e. GM radar in FTT or TGP in non-slave mode) the SPI is slaved to the tracking sensor. If one of the sensors is in tracking state and the pilot is commanding the other sensor to track as well, then the first sensor will break track automatically and update its position with the SPI (which is slaved to the tracking sensor). It is not possible to have both GM radar and TGP in tracking states at the same time.

If no tracking state exists, slewing the GM radar in STP mode will slew the SPI to the same position which will be shared by the TGP. On the other hand, slewing the TGP in STP mode will also slew the SPI and the GM radar to the same position. If the tracking state exists by either sensor and the other sensor is slewed to a different position then the slewing is local and has no effect on the SPI position which stays with the tracking sensor.

Important note: If one of the sensors is in tracking state and the other is slewed you may think there is a bug because the TD box will not move with the slewing sensor. This behaviour is correct behaviour because the TD box is reflecting the position of the SPI which stays with the tracking sensor.

3.1.3 System Delta and its effect on INS/EGI (Embedded GPS/INS)

System deltas are X and Y values which reflect the horizontal difference between the SPI position and the currently selected Steerpoint's original position. The SPI position is initially locked on the STPT position and once SPI is moved (by slewing the FCR or TGP) system delta values change. These delta values are applied to all STPTs, even though the original steerpoint positions (including Bullseye) will still be displayed on the FCR and HSD pages.

This means that when slewing the SPI in A-G mode, your current STPT position is changing too and following the SPI position. You'll see the STPT diamond on the HUD following the SPI position. This change in STPT position affects all navigation STPTs, so even if choosing a different STPT the position will be different than it was originally, as system delta values will have been added to it.

Here is a short example to illustrate how system delta is applied when changing waypoints. On the first image the GM radar cursor and SPI is slewed from its original position on STPT 4, creating a system delta. On the second image the selected STPT is STPT 5 but the system delta is the same and so the SPI/cursor position is adjusted relative to STPT 5.

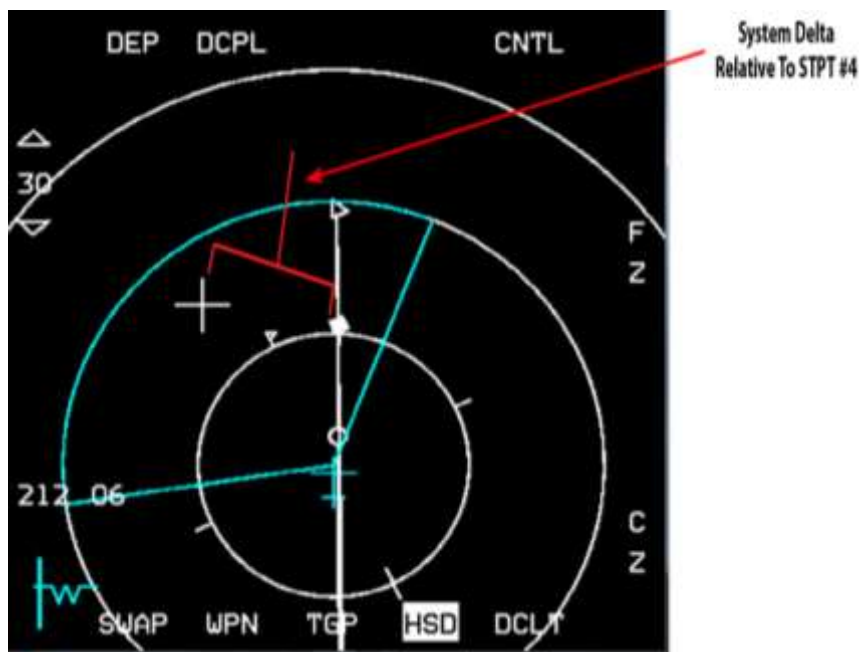

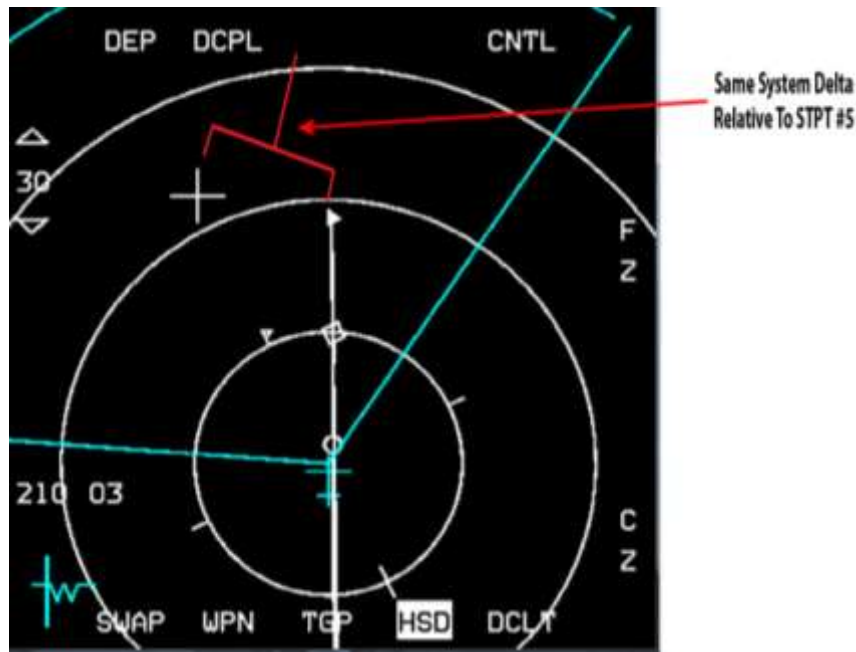

Figure 84 HUD cues related to STPT position

HUD cues related to STPT position can point towards SPI or towards the original STPT position, depending on the selected master mode. The following table describes where the different HUD cues are pointing for each master mode:

	A-A	NAV	A-G
STPT Diamond	SPI	SPI	SPI
Tadpole Cue	STPT	STPT	SPI
Range	STPT	STPT	SPI
Time To Go	STPT	STPT	SPI

Please note: as you can see from the table above you can easily find yourself switching back to A-A or NAV mode after slewing your SPI in A-G mode and being confused by the fact that your tadpole is no longer pointing to your steerpoint diamond. This is because your STPT diamond is still on the SPI and your tadpole is pointing to the STPT.

Pilots should use the following routine to revert the system solution back to the original navigation solution:

1. **TMS down** (to break any sensor tracking state).
2. **Cursor Zero** (to erase any previously created system deltas - see below).
3. **Wide Field of View** (HOTAS pinky or OSB 3 – to reset FCR to NORM/TGP to WIDE).

This habit should be developed after each cursor slew phase and at each IP if cursor slews have been made.

3.1.4 Cursor Zero (CZ)

Cursor Zero (CZ) command will erase any previously created system deltas, return all STPTs to their original position and therefore return SPI position to the current STPT position. CZ can be commanded by pressing the corresponding OSB on the A-G FCR, TGP or HSD MFD pages. CZ command is effective only when no sensor tracking state exists, otherwise the SPI position will not change as the tracking sensor will force it back to the same position.

The CZ mnemonic will be highlighted in aircraft with the Nav EGI upgrade if a system delta exists (i.e. SPI slew).

3.1.5 Snowplow Mode

Snowplow (SP) mode is toggled by pressing OSB 8 on either A-G radar or TGP MFDs. Toggling SP mode sets both sensors into snowplow (SP label will highlight on both MFDs) and not ground-stabilized position, in front of the aircraft and at half the range of the A-G radar scale. TMS Up can then be used to ground-stabilize and allow slewing of the position. SP mode is always in sync between A-G radar and TGP, so if for some reason the A-G radar SP mode is toggled off by switching radar or master modes then the TGP will also exit SP mode. Slewing one of the sensors when in SP mode will also slew the other sensor to the same position similar to how it is working when in normal (STP) mode. The SPI position is not affected when operating in SP mode, meaning that SP mode allows focusing on a position different than the SPI without affecting the SPI.

Note that when Snowplow mode is selected and not yet stabilized (whether set by A-G radar or TGP), SOI is defined as being "nowhere," so both A-G radar and TGP will not have the SOI border and NOT SOI will appear on the MFDs. TMS-Up will stabilize SP position and SOI will normally move to the sensor which was SOI before entering SP mode.

3.1.6 A-G Radar and SPI

When the radar is in STP mode, its position is always in sync with the SPI (the only exception may occur in a case where the SPI is slaved to the TGP because of tracking and the radar is slewed elsewhere). The radar cursor can be slewed freely anywhere with no limitations. Even slewing the cursor outside of the MFD area, the cursor/SPI will keep slewing although the cursor itself will look as it stays stuck on the MFD bounds. When slewing the radar cursor, the SPI position will update as well (on the HUD the TD box will move and the STPT diamond will follow it if the current selected STPT is a navigation waypoint). When the radar isn't SOI (and not tracking a target—i.e., FTT) and the TGP is the SOI, slewing the TGP will slew the SPI position and the radar cursor position as well so all stay in sync. When the radar is in FTT mode (tracking a target) and STPT is changed, the radar will break track and its position will be synced with the new position of the SPI (STPT position + system deltas).

3.1.7 Targeting Pod (TGP) and SPI

When in STP mode the TGP position will be in sync with the A-G radar and with the SPI position (the exception to this case is if the radar is tracking a target and the TGP becomes SOI and is slewed away from the SPI position as the SPI stays with the radar track). If the TGP becomes the SOI then the SPI position will move along and update with TGP slews and the radar position will update to the same location as well. If the TGP is tracking and the STPT is changed then the TGP will break track and sync with the SPI position.

3.2 AGM-65D/G MAVERICK MISSILE

The AGM-65D/G Maverick is an IR, rocket-propelled air-to-ground missile. It is capable of launch-and-leave operations, relying on automatic self-guidance.

The AGM-65D uses a shaped charge warhead optimised for use against armoured vehicles, bunkers, boats, radar vans and small hard targets.

The AGM-65G uses a larger kinetic energy penetrator and blast/fragment warhead that is effective against both unusually shaped targets such as hangars, bridges, and ships and against small point targets such as tanks and bunkers.

The AGM-65D utilises a centroid mode of targeting similar to the AGM-65A and B. In addition to the centroid mode the AGM-65G can also operate in a force correlate mode of operation for aimpoint selection of large targets.

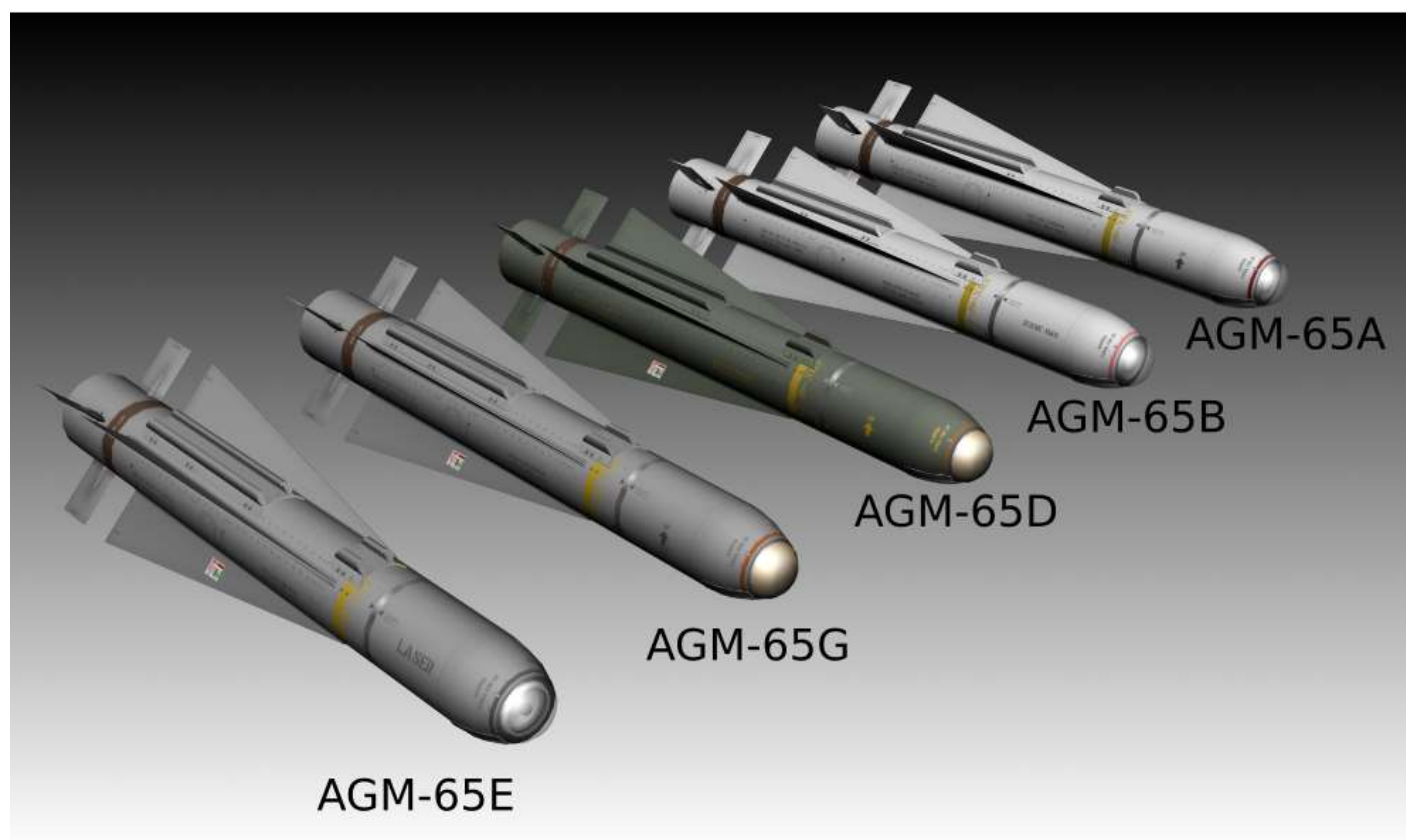

Figure 85 AGM-65 Maverick

The AGM-65D is carried on and launched from LAU-88A/A or LAU-117/A launchers. The AGM-65G is carried on and launched only from the LAU-117 due to its heavier weight.

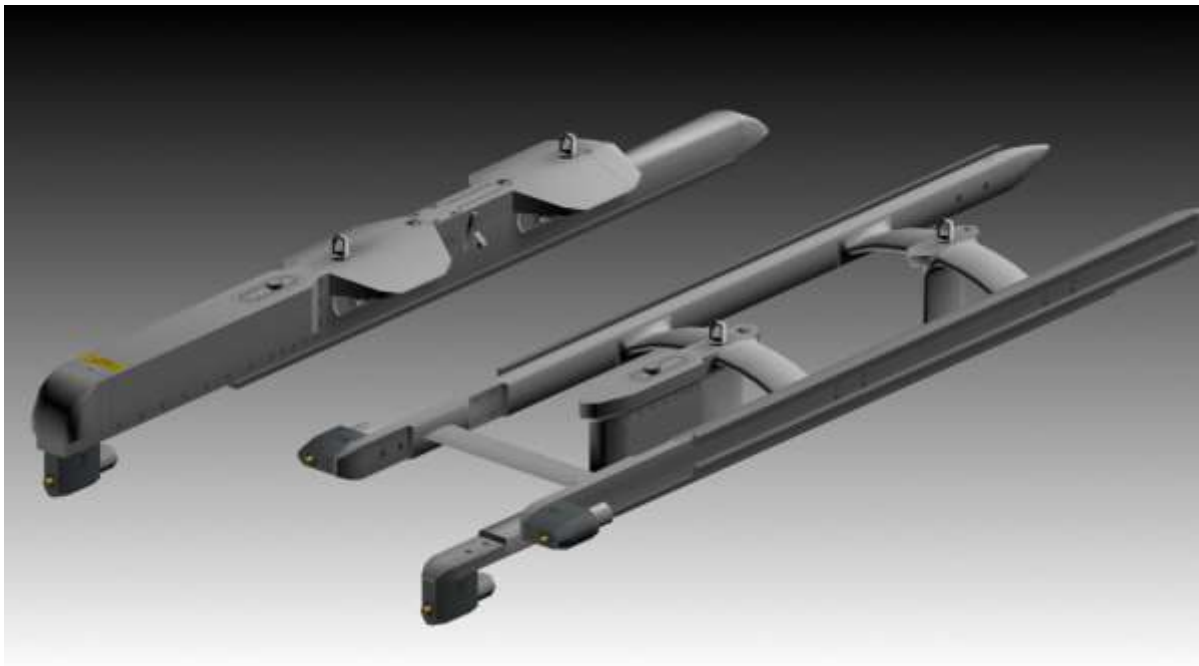

Figure 86 LAU-117/A and LAU-88A/A launchers (above)

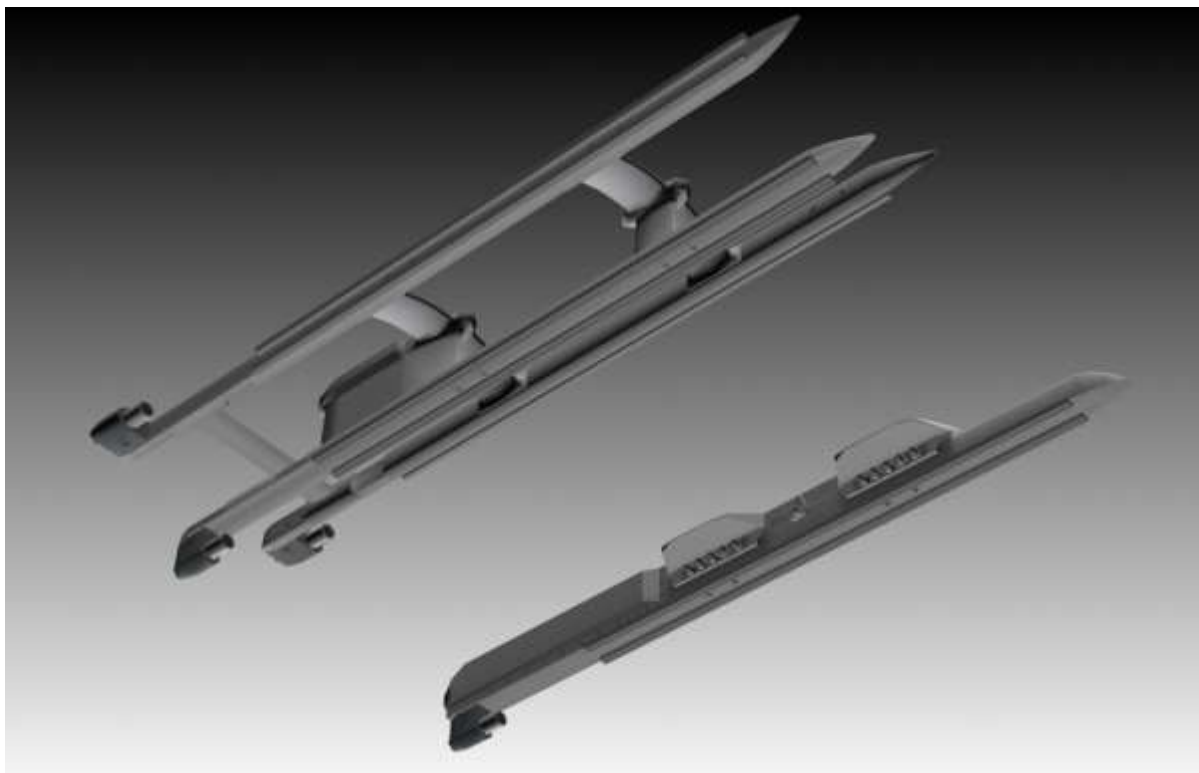

Figure 87 LAU-88A/A and LAU-117/A launchers (below)

3.2.1 AGM-65 Operational Limitations

The maximum carriage airspeed with the AGM-65 is 600 KIAS or 0.95 Mach.

The AGM-65 is always HOT, meaning that it will launch when the pickle button is pressed regardless of seeker gimbal limits or a valid lock (steady weapon pointing cross).

During time of lock on or initiating (TMS Up) handoff do not exceed 30° of bank angle. This will result in an invalid track (flashing weapon pointing cross). Once you've initiated the handoff (and HANDOFF IN PROGRESS has repeated) you can exceed 30° bank and once the target enters the weapon FOV the handoff should complete.

Do not launch the AGM-65 missile under conditions which exceed the following limits:

1. Maximum launch speed: Mach 1.2.
2. Maximum gimbal offset angle: AGM-65A = 15°; AGM-65B = 10°; AGM-65D/G = keyhole (see Figure 91 below).
3. Maximum dive angle: 60°.
4. Maximum bank angle: 30°.
5. Maximum roll rate: 30°/s.
6. Minimum/maximum load factor: +0.5 g/+3.0 g.

3.2.2 AGM-65 Time Limitations

These missile operational time limits represent missile design capability. As a general rule the missile may be operated for longer time periods if the image presented on the cockpit display is usable.

1. Allow 3 minutes gyro spin up time before uncaging to prevent damage due to gyro tumble.

2. Power-On (Ready Mode).

Cumulative per mission – 60 minutes maximum (includes 3 minutes gyro spin-up time).

3. Video-On (Full-Power Mode).

(a) Each attack – 30 minutes maximum (AGM-65D and AGM-65G).

(b) Cumulative per mission – 30 minutes maximum.

3.2.3 HOTAS Functions

Assuming A-G Master Mode, FCR/TGP and WPN page selected.

HOTAS	SOI	Action
<i>MSL STEP</i>		Select next station

<i>CURSOR ENABLE</i>	WPN SOI	Cycle through WPN E-O modes

<i>UNCAGE</i>	WPN SOI	Blow dome cover (AGM-65D)

<i>TMS UP</i>		
	FCR SOI	FCR FTT → WPN SOI → AGM65 LOS. (2 nd TMS UP attempts AGM-65 track)
	WPN SOI (FCR not SOI)	PRE MODE: AGM-65 Track VIS MODE: Stabilizes the TD BOX/AGM-65 LOS BSGT MODE: Stabilizes AGM-65 LOS
	TGP SOI/ WPN PRE	TGP attempts POINT TRACK: If POINT TRACK not successful TGP → AREA TRACK If POINT TRACK successful → WPN HANDOFF attempt

<i>TMS DOWN</i>		
	WPN SOI	REJECT TARGET
	FCR SOI AND FTT	RETURNS TO GM/GMT/SEA
	TGP SOI	POINT → AREA

<i>TMS RIGHT</i>		
	TGP SOI + POINT TRACK	Rejects HANDOFF target and returns to AREA
	WPN SOI	Force Correlation (AREA)

<i>TMS LEFT</i>		
	TGP SOI	WHOT/BHOT/TV
	WPN SOI	COH/BOH

3.2.4 AGM-65 Base Page OSB Functions

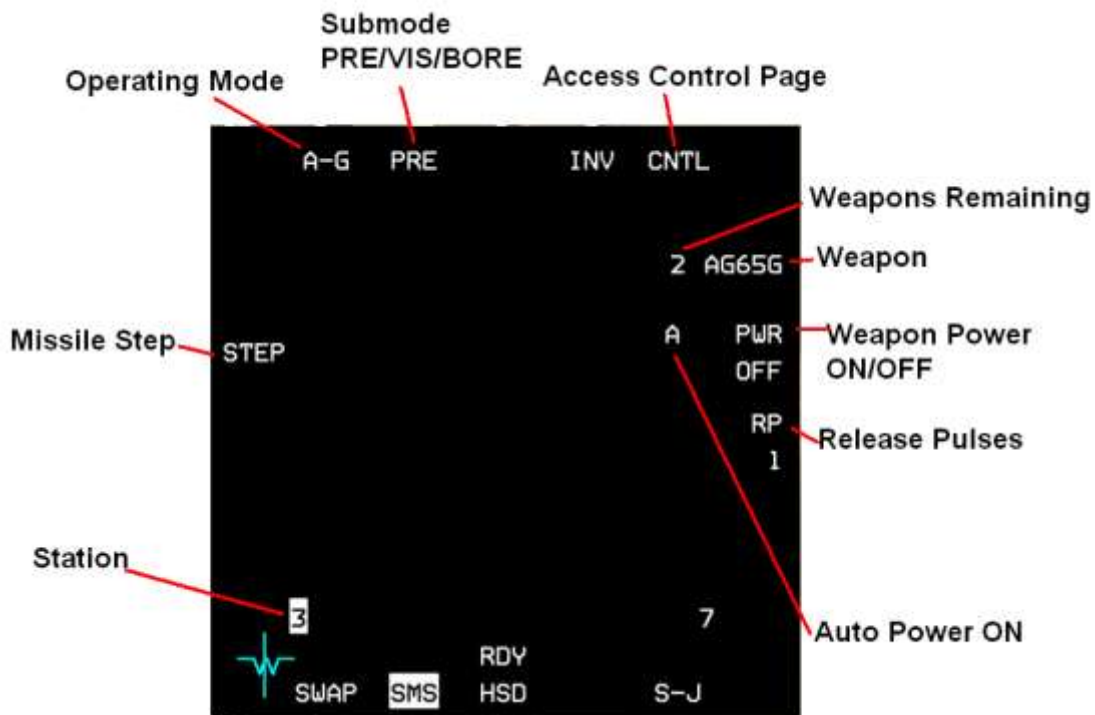

Figure 88 AGM 65 Base Page (SMS EO WPN page)

OSB 1 Operating Mode (A-G/STRF)

OSB 2 E-O sub-modes

- PRE – E-O preplanned delivery.
- VIS – E-O visual delivery.
- BORE – E-O preplanned delivery.

OSB 5 Access to E-O Weapons Control Page

OSB 6 Selected E-O Weapon / Select next available E-O Weapon type

The number of selected weapons remaining and the weapon status are displayed adjacent to the weapon mnemonic. The weapon status mnemonic is also displayed above OSB 13 in descending order of priority as follows:

- REL (release) – Release signal has been issued to weapon.
- RDY (ready) – Weapon is armed and ready for release.
- MAL (malfunction) – Malfunction prohibits release of weapon.

- SIM (simulate) – Weapon is unarmed, but release indications are provided (actual weapon release inhibited).
- Blank – Arming symbology is not displayed on the HUD and release indications are not provided.

Note: Weapon status is displayed after EO-WPN page NOT TIMED OUT message disappears.

OSB 7 Manual Power for selected AGM-65 missiles

PWR ON – Power is being supplied to all selected AGM-65s.

PWR OFF – Power is removed from all selected AGM-65s.

When AUTO PWR ON is selected an A is displayed to the left of the PWR mnemonic on the SMS E-O WPN page; when AUTO PWR OFF is selected the A is not present (see AGM-65 Control page).

OSB 8 Release Pulses

If AGM-65 D/Gs are loaded the number of release pulses requested is controlled via the OSB adjacent to the RP mnemonic and the selected number.

OSB 9-16 Loaded Stations

The active station is highlighted. If the selected station has failed, or is degraded, or is hung an F or D or H will replace the station number.

OSB 18 STEP

If the missile is loaded on the LAU-88/A or -88A/A the STEP mnemonic is also displayed. Depressing the STEP OSB should reject the selected missile and step to the next missile on the selected station. It currently changes the station in the same way as the MSL STEP button, or the OSB adjacent to the station number.

3.2.5 SMS E-O WPN Control/Data Entry Pages

Selecting the CNTL page from the SMS E-O WPN page allows the missiles to be automatically powered up when the aircraft is <2 NM North, East, South or West of a selected steerpoint. The AUTO PWR option is selected/deselected with OSB 7. When AUTO PWR ON is selected an A is displayed to the left of the PWR mnemonic on the SMS EO WPN page; when AUTO PWR OFF is selected the A is not present. The desired steerpoint is changed/selected by depressing OSB 19, accessing the data entry page and keying a valid steerpoint number (1-99). The cardinal position is selected by repeatedly depressing OSB 20 until the desired direction (NORTH, EAST, SOUTH, or WEST) appears.



3.2.6 Electro-Optical Weapon (E-O WPN) Page

The MFD WPN format provides for display of video from AGM-65 missiles. The following E-O states and modes are available:

- OFF – Power to the AGM-65 is not supplied.
- STBY – Power is applied to the AGM-65, but is not fully operational.
- OPER – The AGM-65 is fully operational.
- WPN OFF – Displayed at the centre of the WPN page to indicate that the AGM-65 is not powered.
- NOT TIMED OUT – Indicates that the EO timer has been operating for less than 3 minutes.
- BORE – The AGM-65 is pointed to the nominal HUD boresight.
- BOW – Black-on-white polarity contrast option (AGM-65A/B).
- WOB – White-on-black polarity contrast option (AGM-65A/B).
- AUTO – Automatic polarity contrast option (AGM-65A/B).
- HOC – Hot-on-cold polarity contrast option (AGM-65D/G).
- COH – Cold-on-hot polarity contrast option (AGM-65D/G).
- AREA – Forced correlate option (AGM-65G).
- VIS – Visual E-O sub mode.
- PRE – Preplanned E-O sub mode.
- BSGT – Boresight correction for SLAVE modes (AGM-65D/G).

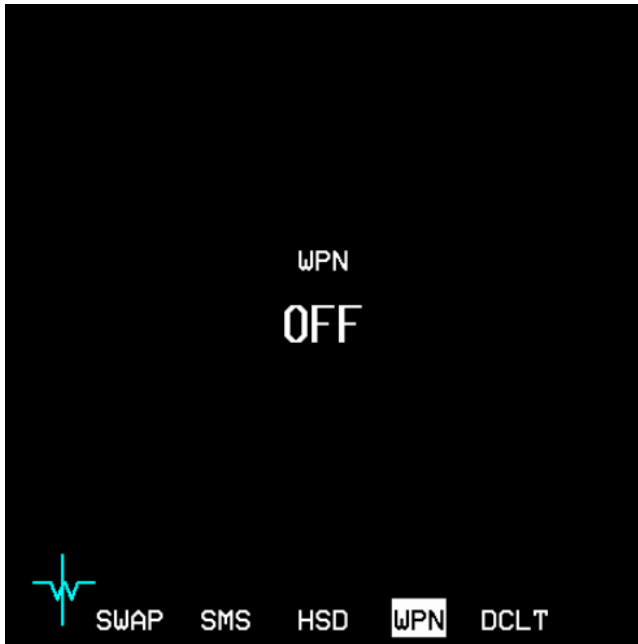

Figure 89 Electro-Optical Weapon (E-O WPN) Page

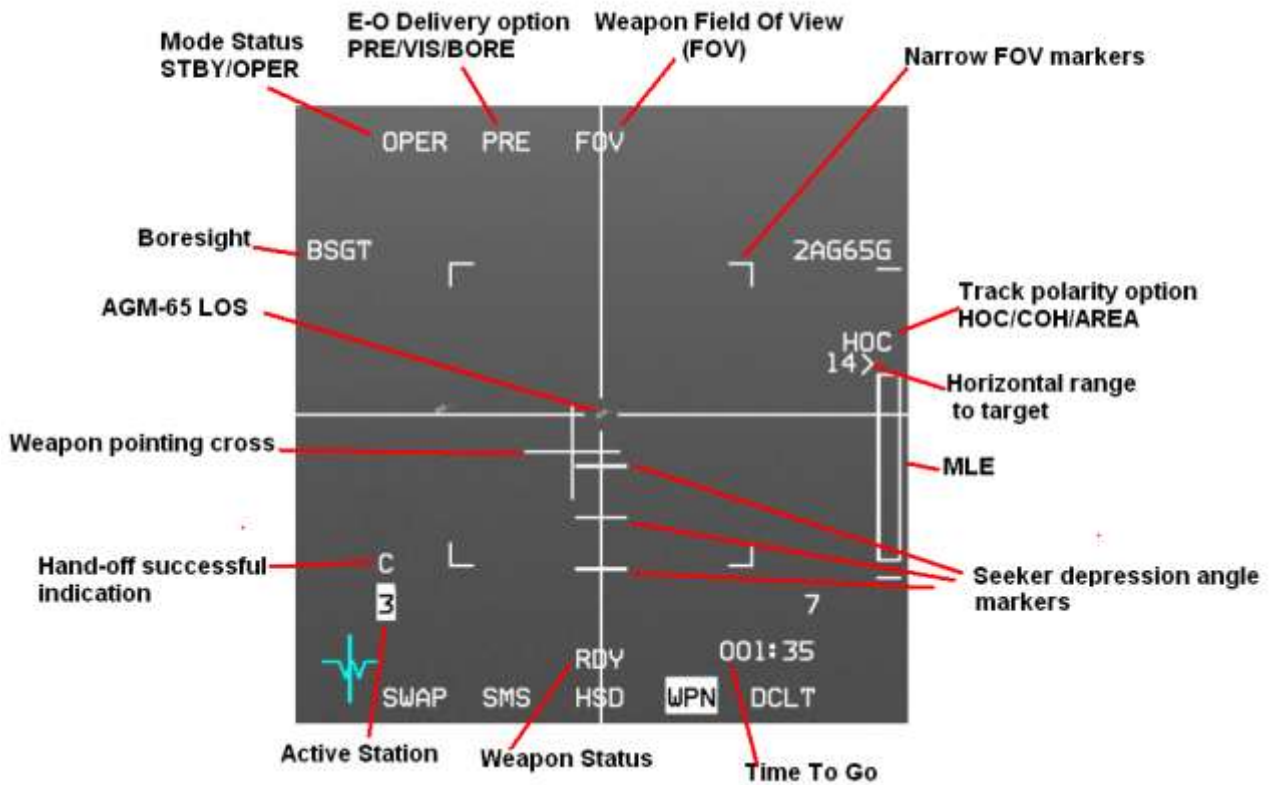

Figure 90 Electro-Optical Weapon (E-O WPN) Page

3.2.6.1 **Video Display**

The video display image is composed of an IR scene video and electronically generated symbols consisting of crosshairs, a pointing cross, seeker depression angle markers and four NFOV markers.

Video display is blank when the MASTER ARM switch is in the OFF position.

Note: AGM-65 power is limited to 1 hour without video and to 30 minutes with video on any one flight. After the maximum on-time has been reached the missile must be powered off for a period of 1 hour for AGM-65D/Gs and 2 hours for AGM-65A/Bs.

3.2.6.2 **Mode Status**

When power is applied to the AGM-65, but it is not fully operational, STBY is displayed below OSB1 along with a NOT TIMED OUT message on the E-O WPN and SMS pages, indicating that the E-O timer has been operating for less than 3 minutes. During STBY the IR image on the weapon page is inhibited.

If the F-16 is on the ground (WOW) the mode status will remain in STBY with the IR image off and the NOT TIMED OUT message displayed, regardless of the E-O timer status, unless the GND JETT switch is moved to the ENABLE position while the mode status is in STBY. When the AGM-65 is fully operational OPER is displayed below OSB1.

When the AGM-65 is not powered WPN OFF will be displayed at the centre of the E-O WPN page.

3.2.6.3 Seeker depression angle markers and keyhole

The Maverick gimbals are 10° in azimuth and 15° in elevation. The 5, 10 and 15° down elevation limits are displayed as horizontal tick marks in the WPN page (available with the AGM-65D/G only) but the azimuth gimbals are not. The gimbal LOS of the missile is actually shaped like an imaginary keyhole centred on the WPN page crosshairs.

Please note: To ensure a valid missile track after launch the pointing cross must be within that imaginary keyhole. If it is not it will most likely flash indicating an invalid track and the missile will almost certainly miss.

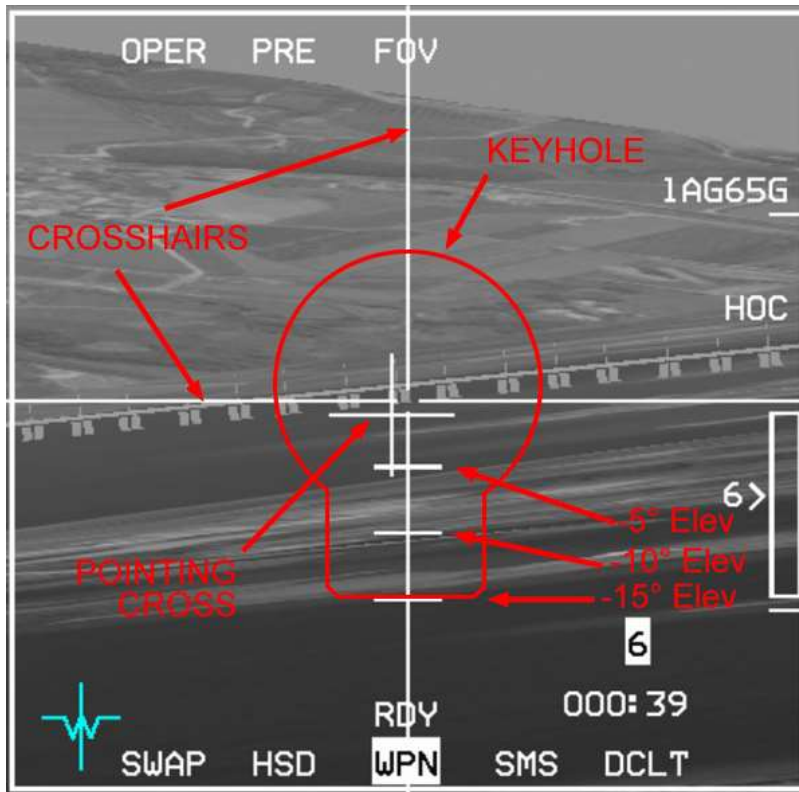

Figure 91 AGM-65D/G keyhole

3.2.6.4 The pointing cross and crosshairs

The displacement of the pointing cross from the centre of the display shows the relative bearing between the LOS of the missile seeker and the longitudinal axis of the missile. Any portion of the pointing cross that is coincident with the tracking window is blanked so as not to interfere with target identification. When a lock-on is attempted the pointing cross will flash until a valid lock is obtained. A steady pointing cross on the display indicates a good lock.

A flashing pointing cross indicates a high probability of break-lock at launch!

The crosshairs are a set of horizontal and vertical lines extending through the centre of the display. The gap at the intersection of the lines delineates the tracking window.

Adjustments of the tracker to accommodate larger targets can result in a widening of the crosshair gap.

The figures below show the gap widening to fit the hangar (and BSGT next to OSB 20 indicating a valid track):

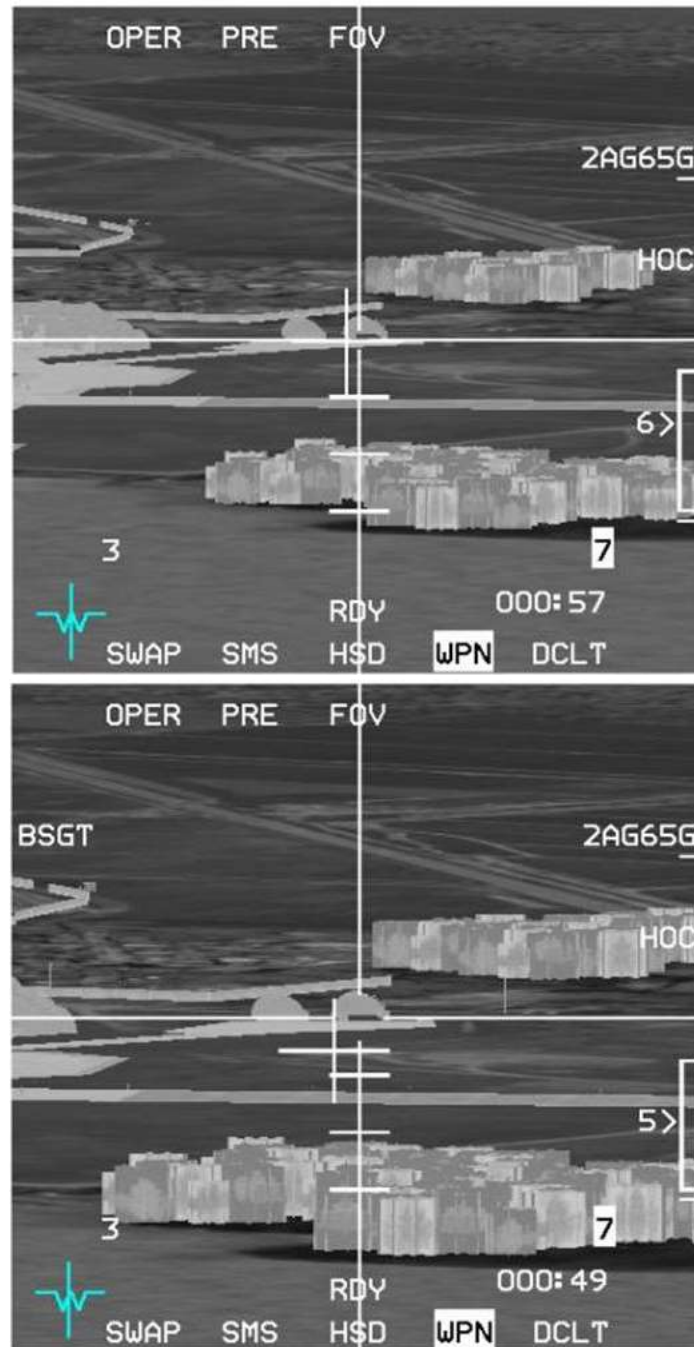

Figure 92 AGM-65 crosshair and blanking area

3.2.6.5 Delivery option

- BORE – The AGM-65 is pointed to the nominal HUD boresight.
- PRE – Preplanned E-O submode.
- VIS – Visual E-O submode.

3.2.6.6 *Field of view*

Dual-FOV capability with Wide (WFOV) for initial target acquisition and Narrow (NFOV) for improved target identification and tracking. FOV is changed via OSB 3 or the pinky switch. Changing the FOV from WFOV to NFOV will remove the NFOV tracking gates, the FOV mnemonic on OSB 3 doesn't change; if you see the gates you are in WFOV.

There is a significant increase in probability of hit for missiles launched in NFOV over missiles launched in WFOV. Advantages of NFOV are improved target identification and increased launch range. Missiles should be launched in NFOV whenever possible. Launching at WFOV may cause a loss of track after launch.

3.2.6.7 *Handoff*

When the Handoff is complete a 'C' is displayed above the selected station (see Targeting Pod E-O Delivery-Handoff).

3.2.6.8 *BSGT*

If the lock on is valid BSGT will be displayed adjacent to OSB 20.

Depressing OSB 20 momentarily highlights the BSGT mnemonic (see Missile Boresight Procedures).

3.2.6.9 *Track Polarity*

- HOC – Hot-on-Cold polarity contrast option.
- COH – Cold-on-Hot polarity contrast option.
- AREA – Forced correlate option (AGM-65G).
- BSGT – Boresight correction for SLAVE modes (AGM-65D/G).

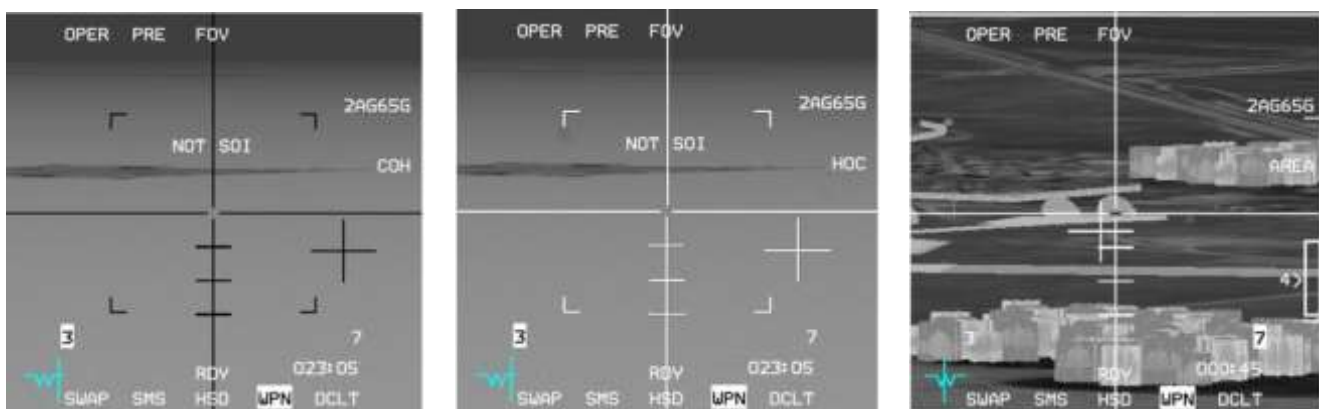

Figure 93 Track Polarity

3.2.7 E-O Delivery

E-O delivery consists of visual (VIS) and preplanned (PRE and BORE) submodes. The E-O delivery submodes provide an option for automatic AGM-65 power up when nearing the target area, automatic video activation with WPN page, automatic SOI switch to WPN page upon target designation and slewing of the AGM-65 LOS without affecting the SPI.

3.2.7.1 PRE – E-O preplanned delivery

The preplanned (PRE) submode is used for delivery of AGM-65 electro-optical weapons against preplanned targets using CCRP-type sighting with the AGM-65 LOS slaved to the FCR or TGP LOS.

With the FCR as SOI TMS UP will command a fixed target track (FTT) over a radar return allowing the FCR to provide range and automatically move the SOI to the MFD WPN page and stabilise the AGM-65 LOS.

The SOI can be moved to the MFD WPN page via DMS AFT if a FTT is not desired or for some reason the radar cannot isolate the designated return.

With the WPN page as SOI a TMS UP will stabilize the AGM-65 LOS with range computed using the steerpoint elevation/barometric elevation. If the AGM-65 is stabilised and needs to be rejected, changing the Master Mode will reset the AGM-65 LOS.

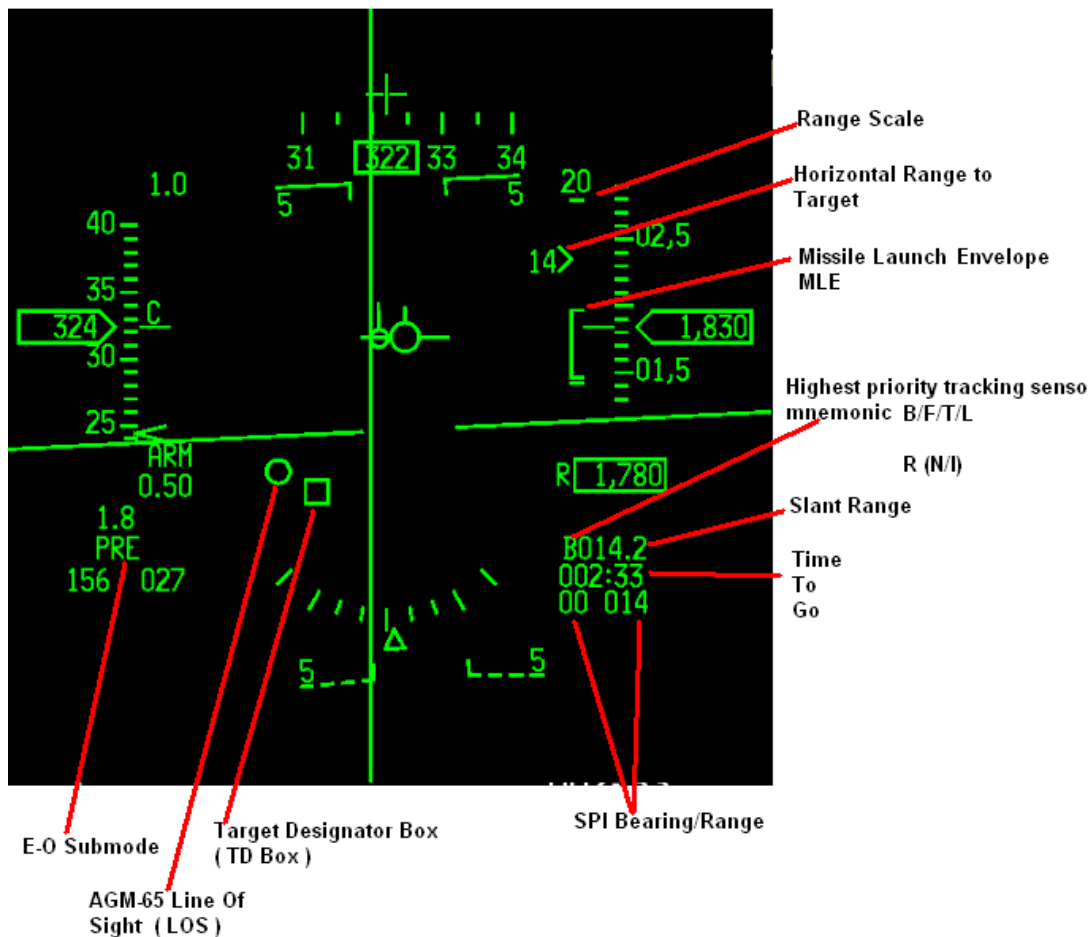

Figure 94 AGM-65 Preplanned Delivery HUD Cues

3.2.7.2 Visual E-O Delivery

The visual (VIS) E-O submode is designed for delivery of AGM-65 electro-optical weapons using dive toss (DTOS) type sighting. In VIS submode, the HUD is initialized as the SOI and the weapon seeker head is slaved to the HUD TD box.

Prior to designating a target, the TD box is caged about the FPM. The TD box can be positioned on the target either by maneuvering the aircraft or with the cursor switch. The target is designated by positioning the TMS up. Designating the target ground stabilises the TD box on or near the target and automatically moves the SOI to the TGP or WPN MFD page (TGP has priority if active). Target rejection should be commanded by manually selecting the HUD as the SOI with DMS up and positioning the TMS down.

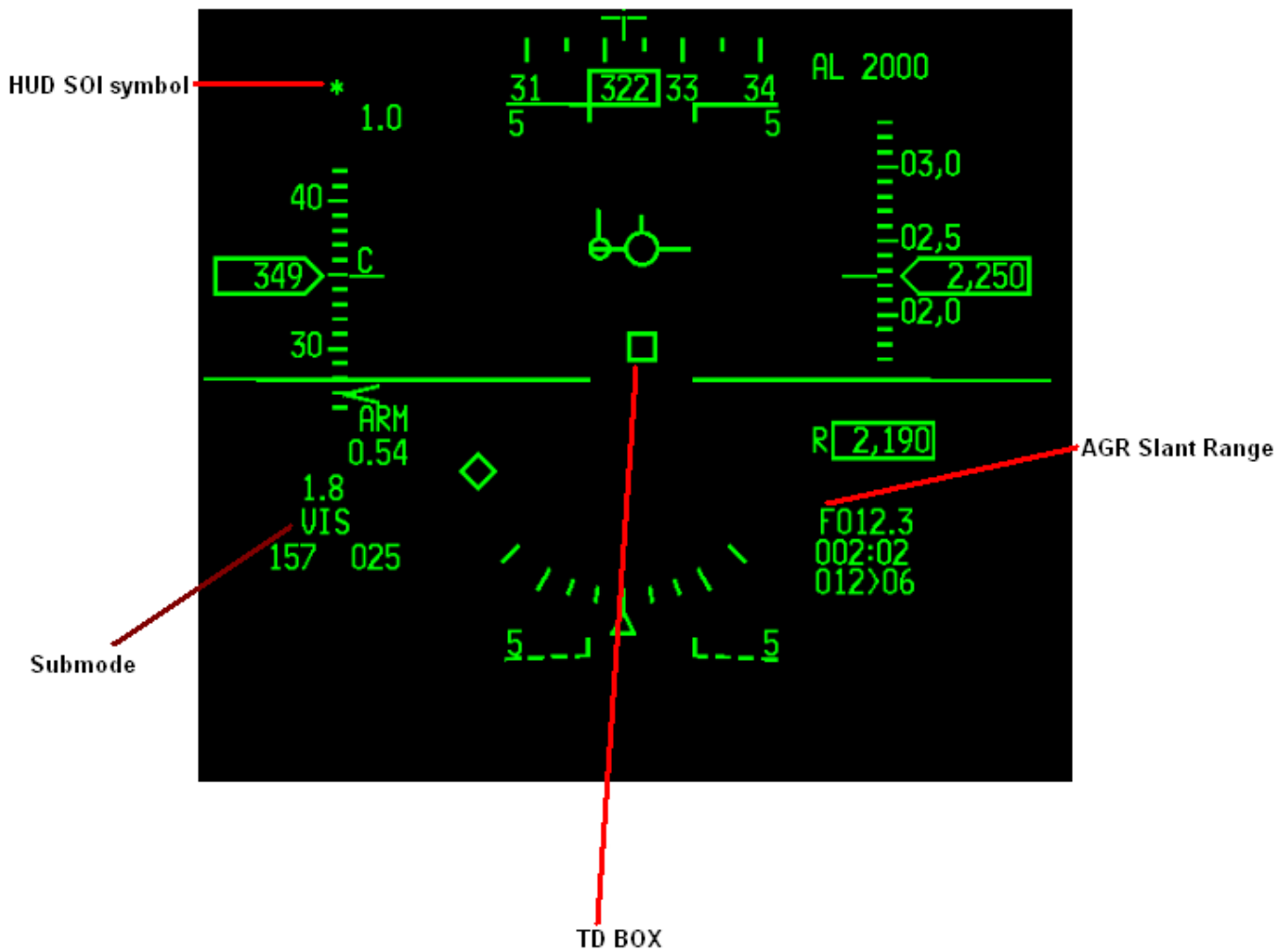

Figure 95 AGM 65 Visual EO Delivery HUD Cues

3.2.7.3 BORE – E-O Delivery

The BORE submode displays are similar to the PRE displays except that the AGM-65 seeker head is pointed to the nominal boresight, which is roughly aligned with the E-O reticle (cross) on the HUD. This allows for firing on targets of opportunity without disturbing the FCR track position. The aircraft is flown to place the HUD E-O reticle on or close to the target. With the WPN format as SOI, the cursor is slewed to refine the AGM-65 target.

The Electro-Optical (E-O) Reticle. The E-O reticle consists of a cross that indicates the E-O weapon is pointed to the armament datum line. For the AGM-65, the E-O reticle is positioned at the armament datum line if the boresight line of sight is selected.

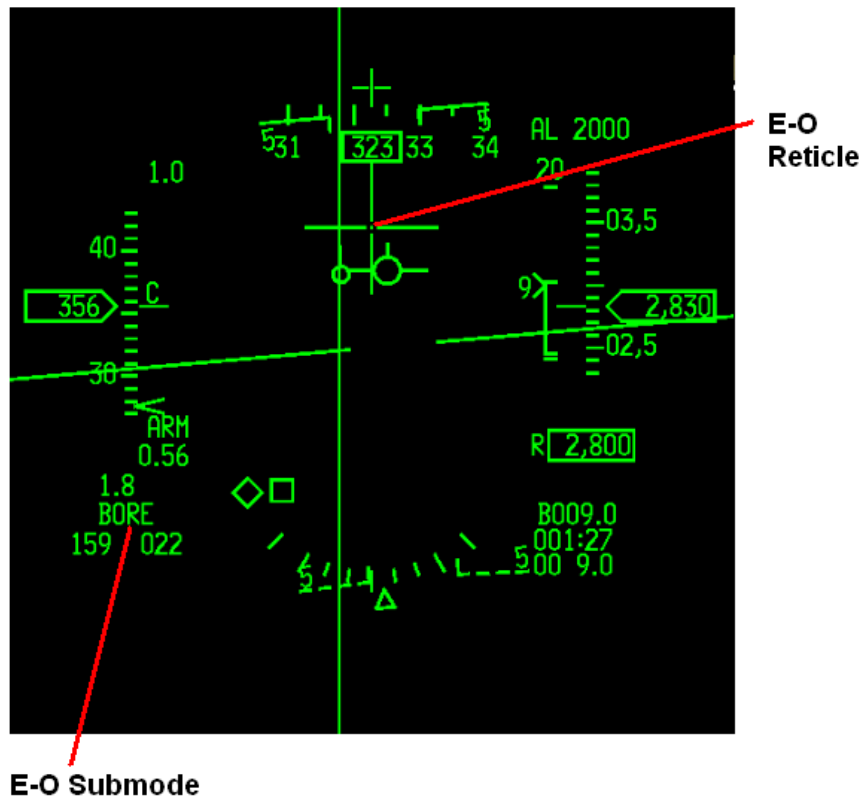

Figure 96 EO Delivery HUD Cues

3.2.7.4 The AGM-65 LOS

The AGM-65 LOS is represented on the HUD as a 10 mr circle. This appears whenever the AGM-65 is slewed or tracking. If the TD box and AGM LOS are both at the same position the TD BOX will be displayed over the AGM-65 LOS as it has display priority.

Two AGM-65 LOS can be stabilised or designated on two different targets prior to launch. Using MSL STEP, select the next station and TMS UP to stabilise the 2nd AGM-65 LOS. Two LOS circles will now exist on the HUD. Next to shoot has a '1' next to the circle and the second to shoot has a '2'. MSL STEP will switch between the two LOS circles. Each station can be configured prior to launch.

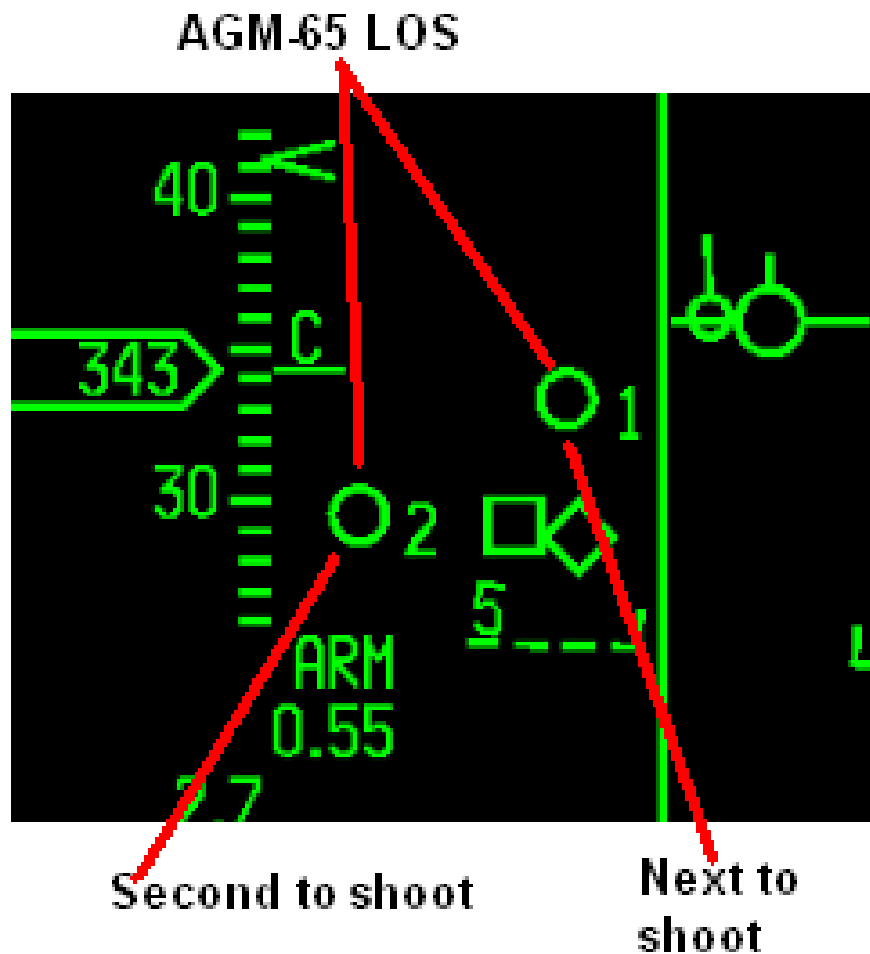

Figure 97 AGM-65 LOS HUD Cue

3.2.7.5 *Bearing/Range to TGT*

Relative bearing is displayed in tens of degrees from the aircraft to the target or SPI. Ranges greater than 10 miles are displayed in nautical miles; ranges of less than 10 miles are displayed in tenths of nautical miles.

In VIS mode relative bearing and range to SPI are available only after the AGM-65 LOS is stabilised.

3.2.7.6 *Slant range*

Displays the measured slant range to an air-to-air target or ground sighting point from the highest priority tracking sensor and a mnemonic identifying that sensor. The mnemonics are: F, B, T, L, R (N/I)

- F is displayed when the FCR is providing range.
- R is displayed when the radar altimeter is providing range (N/I).
- B is displayed if the range is computed using steerpoint elevation/barometric elevation.
- T is displayed when the TGP is providing passive range.
- L when the TGP laser is firing and being used.

Slant range is displayed in tenths of nautical miles for ranges greater than 1 nautical mile and hundreds of feet for ranges less than 1 nautical mile.

3.2.7.7 *Time to Go*

In Air-to-Ground weapon delivery modes its function is mode-dependent.

In E-O WPN mode, TTG is the calculated time for the aircraft to arrive at the selected SPI TD box.

3.2.7.8 *Range Scale / MLE*

A missile launch envelope (MLE) scale is displayed on the HUD and on the MFD WPN page to assist in determining valid range conditions for an AGM-65 launch.

The Range Scale is AGM-65 type dependent:

- AGM-65A/B range scale is fixed at 10nm.
- AGM-65D range scale is fixed at 15nm.
- AGM-65G range scale is fixed at 20nm.

The two fixed tick marks represent the scale boundaries, with the range cue representing the horizontal range to the target. A target range window positioned next to the cue displays the range in nautical miles.

The dynamic open-sided rectangle (DLZ) represents the missile footprint (Rmax and Rmin). On the WPN page the rectangle is solid.

Because the AGM-65 line-of-sight range is not available to the avionic system, the target range cue is positioned using range to the target coordinates (SPI). Furthermore the bearing/range, slant range and azimuth steering line are also 'tied' to the SPI.

If the AGM-65 LOS circle has been slewed off of the target (seeker head slewed independently of the SPI), the MLE will be somewhat inaccurate. The SPI can be slewed over the MAV LOS after stabilisation or lock on, to assist in a more accurate ranging.

The MLE is available when the following conditions are met:

- SLAVE post-designate entered.
- AGM-65A/B/D/G selected.
- Horizontal range to target less than 15 nm.
- Target within $\pm 30^\circ$ of the aircraft yaw axis.
- INS data is valid.
- CADC data is valid.



Accurate ranging (SPI TD BOX is 7nm)

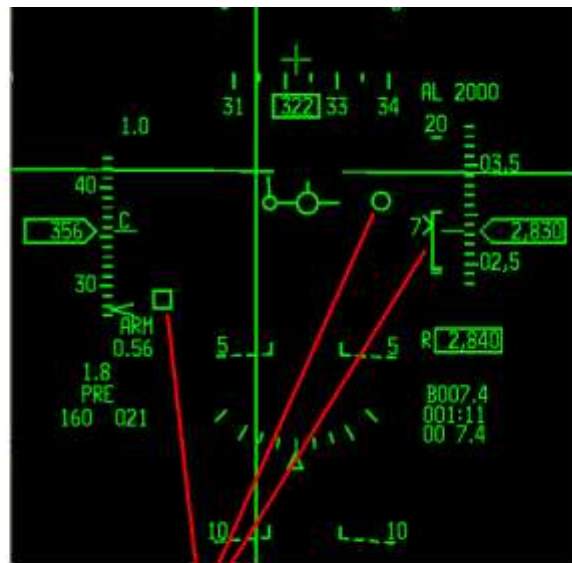

Inaccurate Ranging. MAV LOS slewed away from SPI

Figure 98 AGM-65 accurate vs. inaccurate ranging

3.2.7.9 Force Correlation Track (AGM-65G Missile Only)

Some large targets may not be suitable for attack with an AGM-65G operating in the centroid track mode. A specific aim point different from the centroid of the target may be the desired impact point (a certain building in an industrial complex, a specific span of a bridge, etc.). The AGM-65G has a feature that allows the tracker to be forced into the correlation track mode prior to launch to track a specific aim point. This action bypasses the centroid track circuitry.

To force the missile into correlation track mode the AREA (OSB 7) position of the aircraft Contrast Select switch is used with the WPN page SOI. Pressing OSB 7 cycles through the options: HOC→COH→AREA→HOC...

SLEW actions are performed normally. Prior to commanding track (lock-on), selection of the AREA position must be made. When TRACK is commanded, target tracking will be accomplished through the correlation tracker circuitry. When lock-on occurs, the crosshairs will close, creating solid crosshairs in both the horizontal and vertical axes on the aim point in the centre of the display. The pointing cross will indicate when good-lock logic criteria have been met.

Note: When the AGM-65G is set to Force Correlation Track (AREA) mode, the missile is not compatible with TGP E-O Delivery (Handoff).

Note also: AREA mode cannot be used with COH polarity so TMS-left will be disabled when in AREA mode.

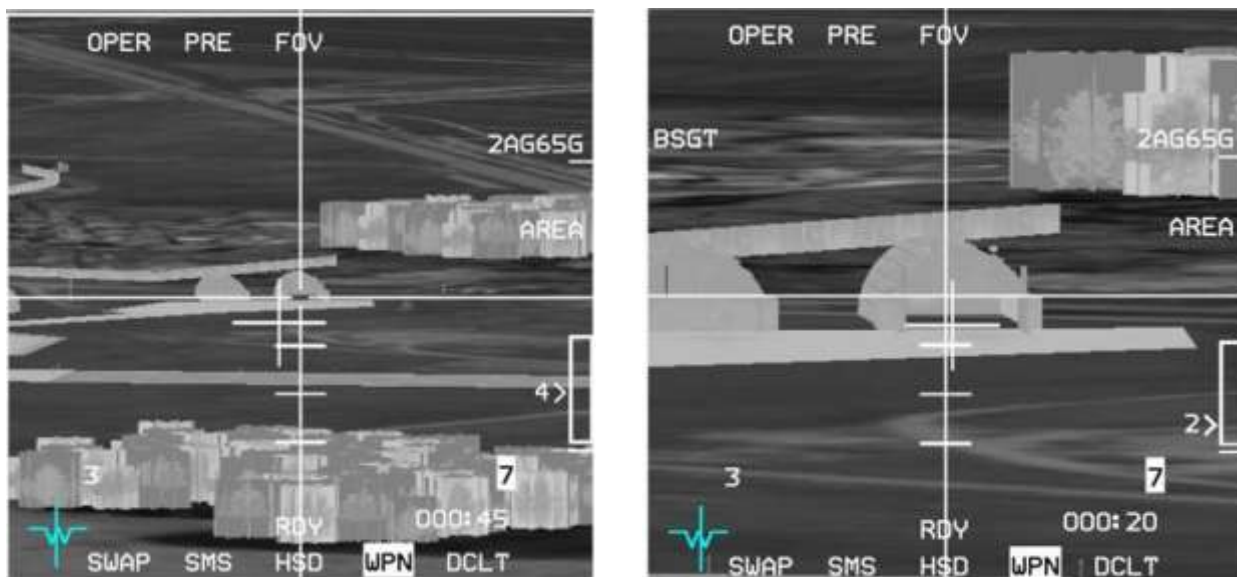

Figure 99 AGM-65G Force Correlation Track

3.2.8 Targeting Pod E-O Delivery (Handoff)

Note: This capability is only available when AGM-65D or AGM-65G missiles are loaded, the TGP is operational and the SOI is not on the WPN page.

The TGP is used to detect and track targets for semi-automated AGM-65D/G delivery. The missile boresight correlator (MBC) takes control, selects, configures, and controls missile slew and lock-on of the AGM-65D/G to achieve a tracking missile. This automated mechanization reduces workload by deleting the requirement of interfacing with the WPN page. When in A-G mode with an AGM-65D/G selected and the SOI is the TGP, the MBC is active.

The TGP is operated in POINT track to support the missile. The AGM-65 video is compared to the TGP video and slewed to align with the TGP video; track is then commanded.

Note: If the TGP is SOI and in WIDE FOV switching to NARO FOV (with pinky switch or OSB 3) will automatically switch the AGM-65 WPN page to NFOV (no tracking gates will be visible).

In POINT track, if an AGM-65 D/G is selected, the TGP attempts to hand-off the target to the missile and the message HANDOFF IN PROGRESS STATION X (where X is the active missile station) is displayed on the WPN page.

If the handoff is successful, a complete indication 'C' is displayed above the weapon station and a small box on the bottom of the AGM-65 LOS circle indicates a successful handoff on the HUD (see Figure 102); if the handoff is incomplete an 'I' is displayed above the weapon station. If the pod is then slewed to a new target and another AGM-65 D/G missile is selected, the TGP attempts to hand-off the new target to the new missile.

Note: there is a bug with a valid lock on when the target is outside the AGM-65 FOV. If handoff is commanded while the bank angle is $< 30^\circ$, followed immediately by a turn towards the target with a bank angle exceeding 30° , it results in an invalid track. To avoid this wait until *after* the "HANDOFF IN PROGRESS" message is repeated (flashes) on the WPN page before turning towards the target. The result is a valid track.

TMS-right, with TGP SOI, at any time, causes the last missile to reject the last target.

3.2.8.1 Handoff status

Handoff status is displayed above the station numbers on the TGP page.

The following summarises status indications:

- **S** – Slave. The missile is slaved to the TGP but not tracking.
- **1** – Slew. The TGP is moving the missile LOS based on comparison of the missile LOS and the TGP LOS.
- **2** – Slew. The TGP is moving the missile LOS based on comparison of the missile and TGP video.
- **T** – Track. The TGP has commanded the missile to track.
- **C** – Complete. Handoff is complete, missile is tracking.
- **I** – Incomplete. Handoff has failed, missile is not tracking.

Note: Phase 2 can compensate for a little bit of boresight error. If there is too much, handoff will oscillate between phase 1 and 2. In the 'T' Phase, if the Maverick cannot track, it will keep trying until handoff is aborted or times out.

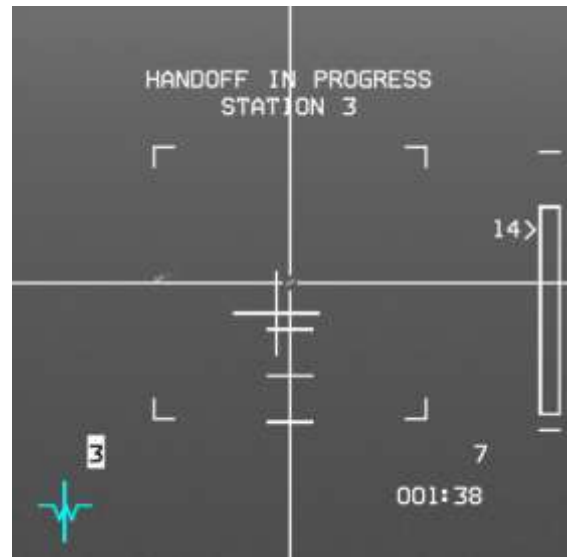

Figure 100 POINT track - TGP attempts handoff (HANDOFF IN PROGRESS shown on WPN page)

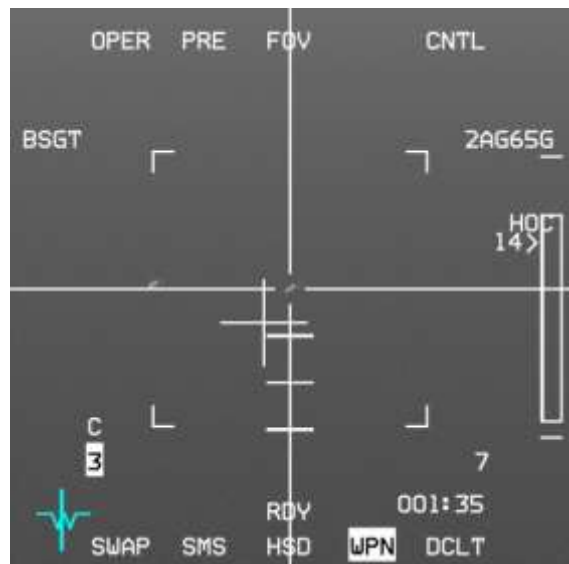

Figure 101 Handoff Complete (also indicated with C above station number on WPN page)

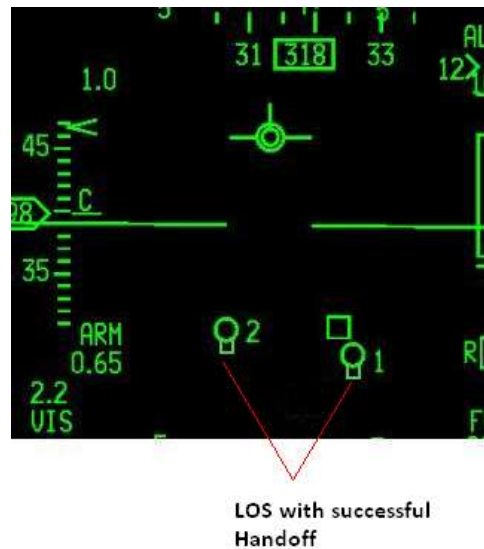

Figure 102 LOS with successful handoff

3.2.8.2 Alignment of AGM-65D/G Boresight to the Targeting Pod

The AGM-65 mounting procedure induces an unknown amount of misalignment of the launcher. This misalignment must be removed to improve accuracy and shorten the time required to achieve a handoff. Misalignment is corrected by boresighting the missile LOS to the TGP LOS. The AGM-65 boresight procedure may only be performed on the ground if the missiles do not have dome covers installed. If dome covers are present, the procedure must be done while airborne.

3.2.9 AGM-65D/G Missile Boresight Procedures

AGM-65 boresight should not be attempted on the ground if dome covers are still in place.

To accomplish missile boresight, either a LAU-88A/A (AGM-65D), LAU-117/A, LAU-117A(V)1/A, or LAU-117A(V)3/A (AGM-65D and G) launcher is required. The boresighting procedure only needs to be done once per launcher, even if there is more than one AGM-65D missile on that launcher.

When the inventory on any weapon station is changed all AGM-65 missiles will power off. The pilot must power on the missile and wait again for the (up to) 3-minute timeout. If the missile has previously been powered up this timeout may take considerably less time.

AGM-65D/G power is limited to 1 hour without video and to 30 minutes with video on any one flight. If you do not intend to fire your AGM-65s immediately after boresighting you should power them off after completing the procedure and then power them back on at IP.

AGM-65 boresight may be accomplished visually in VIS, or with the FCR, or with the TGP.

3.2.9.1 **AGM-65D/G Missile Boresight Procedures**

1. If on ground – GND JETT to ENABLE
2. ICP – Depress A-G button
3. Left MFD – Select desired pages (n/a if boresighting in VIS):
 - (a) FCR page – Select GM/GMT/SEA submode
 - (b) TGP page (if TGP available) – Select A-G submode
4. Right MFD – Select desired pages:
 - (a) SMS page – Depress OSB 7 (PWR OFF) to power up AGM-65s (OSB changes to PWR ON)
 - (b) WPN page – Confirm PRE submode (if boresighting in VIS – CURSOR ENABLE to change to VIS)
5. HUD – Confirm PRE symbology in lower left corner (or VIS if boresighting in VIS)
6. DMS – Select required sensor (TGP or FCR) as SOI (n/a in VIS – HUD will have * SOI indicator in top left corner)
7. MASTER ARM – ARM or SIM (as desired)
8. WPN page – NOT TIMED OUT disappears after <=3 minutes
9. UNCAGE – (if no video image in WPN page) and switch to NFOV as required
10. MSL STEP – repeat UNCAGE/NFOV for next hardpoint
11. TGP or FCR SOI – TMS Up to ground-stabilize sensor (if necessary)
12. Acquire target and expand FOV as necessary (n/a if boresighting in VIS)
13. TGP or FCR or HUD SOI – TMS Up to designate target. If TGP is SOI then move on to 14. WPN page, else:
 - (a) After POINT Tracking target WPN page may remain in HANDOFF IN PROGRESS
 - (b) AVIONICS FAULT lights up, PFLD shows TGP HADF FAIL, MASTER CAUTION light comes on
14. WPN page – Slew AGM-65 gates over the target
15. TMS - Up and release; confirm correct target tracked and that BSGT appears next to OSB 20
16. WPN page – Depress OSB 20 (BSGT)
17. MSL STEP button – Depress to select next hardpoint
18. Repeat steps 14-17 for additional AGM-65D/G launchers
19. (TGP only) – Press F-ACK to clear PFL; ‘AV’ will remain lit on right side of PFLD status line
20. SMS page – Depress OSB 7 (PWR ON) to power off AGM-65s (unless testing HANDOFF or firing them immediately)
21. If on ground – GND JETT to OFF (unless testing HANDOFF - then delay until after AGM-65s powered down)

Optional steps (TGP only) to test if you can successfully HANDOFF a target after boresighting:

22. Go to DGFT or MISSILE OVERRIDE (any master mode change) to reject all targets then switch back to A-G mode
23. TMS - Up to POINT TRACK desired target; WPN page shows HANDOFF IN PROGRESS
24. 'C' appears over the station number on the WPN (and TGP) page when target successfully handed off
25. AV light in PFL goes off
26. Confirm AGM-65 is tracking the correct target
27. MSL STEP button – Depress to select next hardpoint and repeat step 23 (if desired)
28. SMS page – Depress OSB 7 (PWR ON) to power off AGM-65s (unless using them immediately)

Note: Slewing your ground cursor position (SPI) during the boresighting procedure will effectively slew your current steerpoint by adding a system delta to all steerpoints. All NAV and weapon delivery steering and symbology, including the great circle steering cue (tadpole) will be referenced to the amended steerpoint(s).

The CZ mnemonic will be highlighted in aircraft with the Nav EGI upgrade if a system delta exists (i.e. SPI slew).

Cursor Zero (CZ) will erase any previously created system deltas, returning all STPTs to their original position and SPI to the current STPT position. CZ can be commanded by pressing the OSB marked CZ on the A-G FCR, TGP or HSD MFD pages. A Cursor Zero command is effective only when no sensor tracking state exists, otherwise the SPI position will not change, as the tracking sensor will force it back to the same position.

Note also: if you carry a TGP and plan to use HANDOFF during your attack you are not limited to boresighting with the TGP; you can boresight in VIS (or with the FCR) as you prefer and then optionally test HANDOFF afterwards before you power down your missiles.

3.3 AGM-88 HARM

The AGM-88 High-speed Anti-Radiation Missile (HARM) is a tactical, air-to-surface missile designed to home in on electronic transmissions coming from surface-to-air radar systems. It was originally developed as a replacement for the AGM-45 Shrike and AGM-78 Standard ARM system.

The AGM-88 can detect, attack and destroy a radar antenna or transmitter with minimal aircrew input. The proportional guidance system that homes in on enemy radar emissions has a fixed antenna and seeker head in the missile's nose. A smokeless, solid-propellant, booster-sustainer rocket motor propels the missile at over Mach 2. HARM, a U.S. Navy-led program, was initially integrated onto the A-6E, A-7 and F/A-18 and later onto the EA-6B. RDT&E for use on the F-14 was begun, but not completed. The USAF introduced HARM on the F-4G Wild Weasel and later on specialized F-16s equipped with the HARM Targeting System (HTS).



Figure 103 AGM-88 HARM

3.3.1 SMS Base Page

Missile power is selected via OSB 7 adjacent to the PWR ON/PWR OFF mnemonic on the SMS base page. When PWR ON is selected, all of the missiles loaded on the aircraft (of the selected type) are simultaneously powered up.

The selection of PWR ON automatically launches a BIT sequence. The BIT sequence last approximately 10 seconds and is identified by the BIT mnemonic being highlighted.

Once the BIT sequence is completed and successful, "RDY" is displayed at the bottom of the MFD page.

Missiles remain powered up until PWR OFF is selected or a change is made to the current weapon inventory.

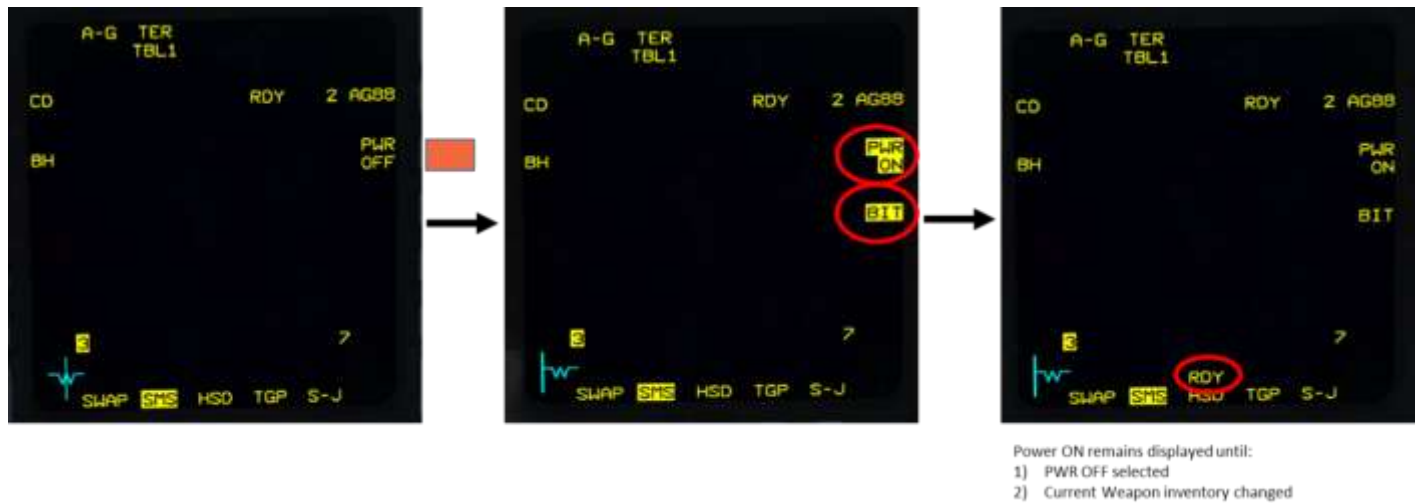

Initiating BIT manually is possible and might clear a faulty missile. OSB 8 can be depressed to initiate a BIT on the HARM missiles. The BIT mnemonic highlights when the BIT is performed, and "RDY" will be displayed when successful.

When an anti-radiation missile is selected, the appropriate mnemonic (AG88) is displayed adjacent to OSB 6 on the SMS base page, along with the total number of missiles loaded in inventory.

AGM-88 weapons have automatic station selection logic and selection order with MASTER ARM in MASTER ARM. When stepping between loaded stations (HOTAS MSL STEP), the avionics system remembers the launch parameters selected for that particular station and will initialize to the last known launch parameters when returning to that station. You can have thus one missile on station 3 pre-programmed with POS EOM at a set steerpoint and missile on station 7 preset with HAS mode. MSL STEP button on side stick will step missiles as usual.

It is good practice to set the left MFD as A-A FCR and right MFD as HSD and WPN page.

3.3.2 HARM Modes

HARMS in BMS can be used in 3 modes:

- Position (POS) subdivided into 3 submodes: EOM, PB, RUK.
- HARM as Sensor (HAS).
- HARM Attack Display (HAD) (Works only when the HARM Targeting System (HTS) pod is carried). HAD also has three submodes: EOM, PB, RUK.
- DL is not implemented

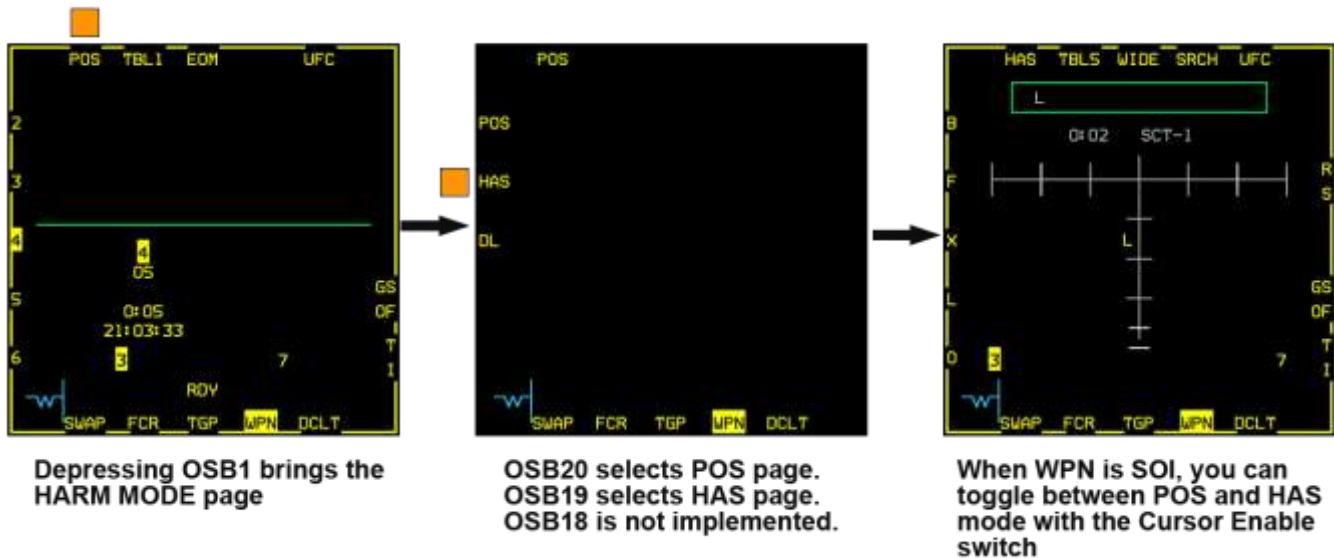

3.3.3 POS Mode

In POS mode, the missile is fired at a steerpoint (POS = Position) and will look for a threat emitter. HARMS can be fired in anticipation (SAM radar silent) when knowing where the SAM site is likely to be located (STPT or PPT). This kind of attack is to be conducted against planned threats.

Once launched the missile will fly to the steerpoint area, activate its seeker depending on the submode selected and look for the handed off threat.

If a SAM radar comes online, the missile will target it as before with BMS 4.34.

BMS 4.35 changed the behaviour in case no radar is radiating by implementing new functions:

If no radar is radiating, the missile will either FLEX or GLIDE based on the Target Isolate (TI) and the Geographic Specificity (GS) options.

FLEX means the missile will search for another target while GLIDE enters a different flight path to maximize its flight time.

If no target is found, it will likely miss. TI and GS will be discussed, at length, in a later section.

An important point to remember is that the pilot has no clue if the SAM radar is radiating from the MFD WPN page in POS mode. Remember you fire at an area and let the missile make its search depending on POS submode, threat type, and TI/GS options.

The threat type, steerpoint, TI and GS options must be loaded into the missile prior to launch; this is called the Handoff process. Any last-minute change to one of those parameters requires that another handoff be initiated (pressing the threat OSB twice). When the handoff process is successful, "RDY" is displayed at the bottom of the WPN page. Switching missile stations using MSL STEP will begin a new handoff sequence, so wait for completion before launching.

A missile launched without the RDY state will result in a miss.

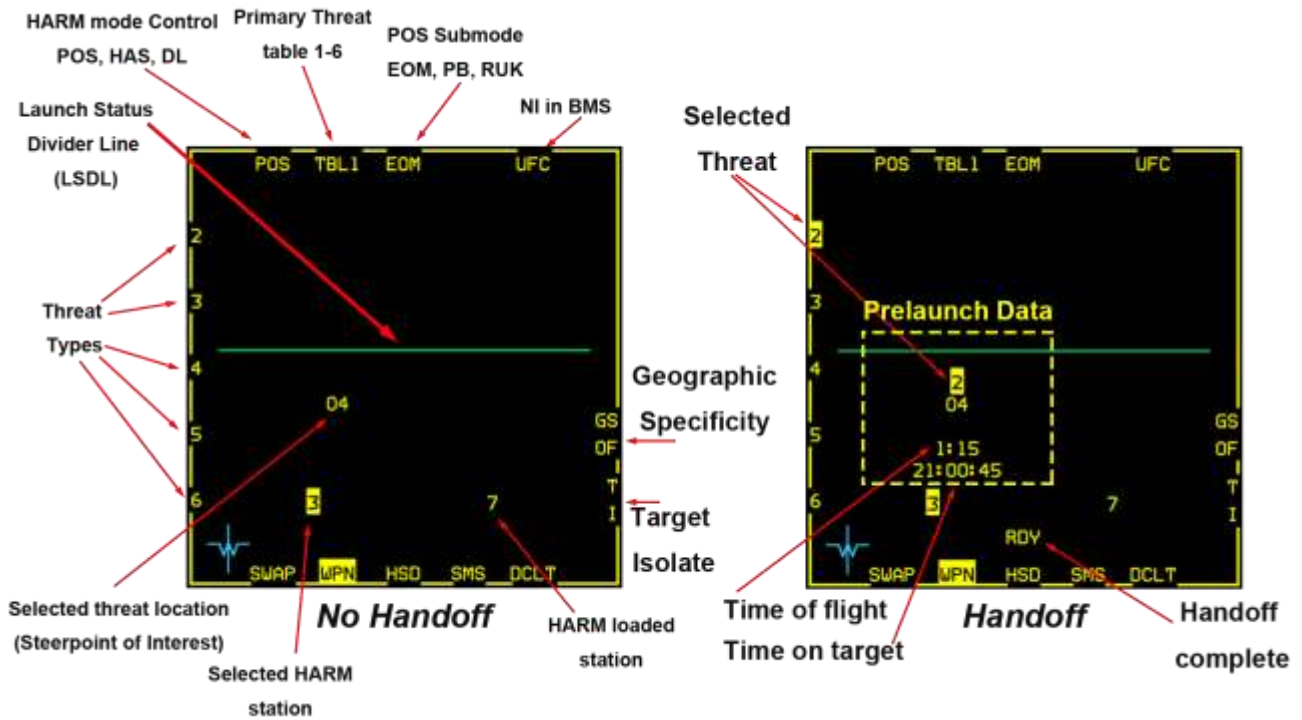

The centre of the POS base page contains missile employment information. It is divided into two sections by the launch status divider line (LSDL - Green line).

Prelaunch information is displayed below the LSDL directly above the selected missile station.

Post Launch information is displayed above the LSDL and in reverse order from the station.

Threat types within the same TBL are displayed along the left side of the display.

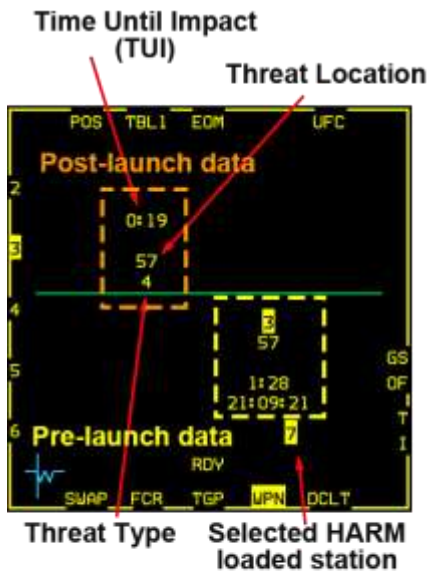

HARM has been launched from station 3 at threat SA4 on STPT 57. HARM on station 7 has handed-off threat (SA3) but still on same location (PPT57)



Assigned new location to HARM on station 7 from UFC while 1st HARM is in flight

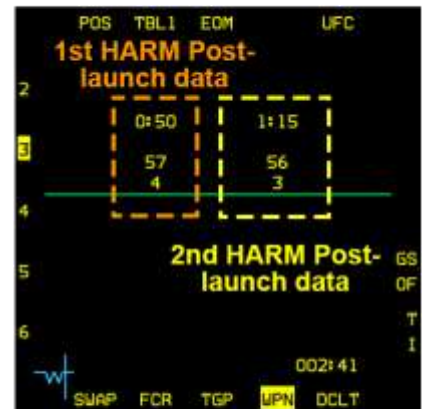

2nd launch while 1st HARM still in flight

There are three Position Known (POS) flight profiles: OSB 3 provides sub mode selection. Each mode controls where the missile will activate its seeker and which one of the two FOV settings will be used.

- Equation of Motion (**EOM**) is the most accurate POS submode. The seeker is activated with a narrow Field of view, quite close to the known threat position. This mode should only be used when the location of the emitter is well known (i.e. collocated to a steerpoint)
- Pre-Briefed mode (**PB**) is used for long range delivery with high confidence target location. The Seeker will activate a bit further than EOM from the steerpoint with a wider FOV.
- Range Unknown (**RUK**): is used when there is high uncertainty about threat range. The seeker is activated at long range from the steerpoint with an equally wider FOV.

Depressing the pinky switch (S3) on the stick will toggle sub modes when the WPN page is SOI.

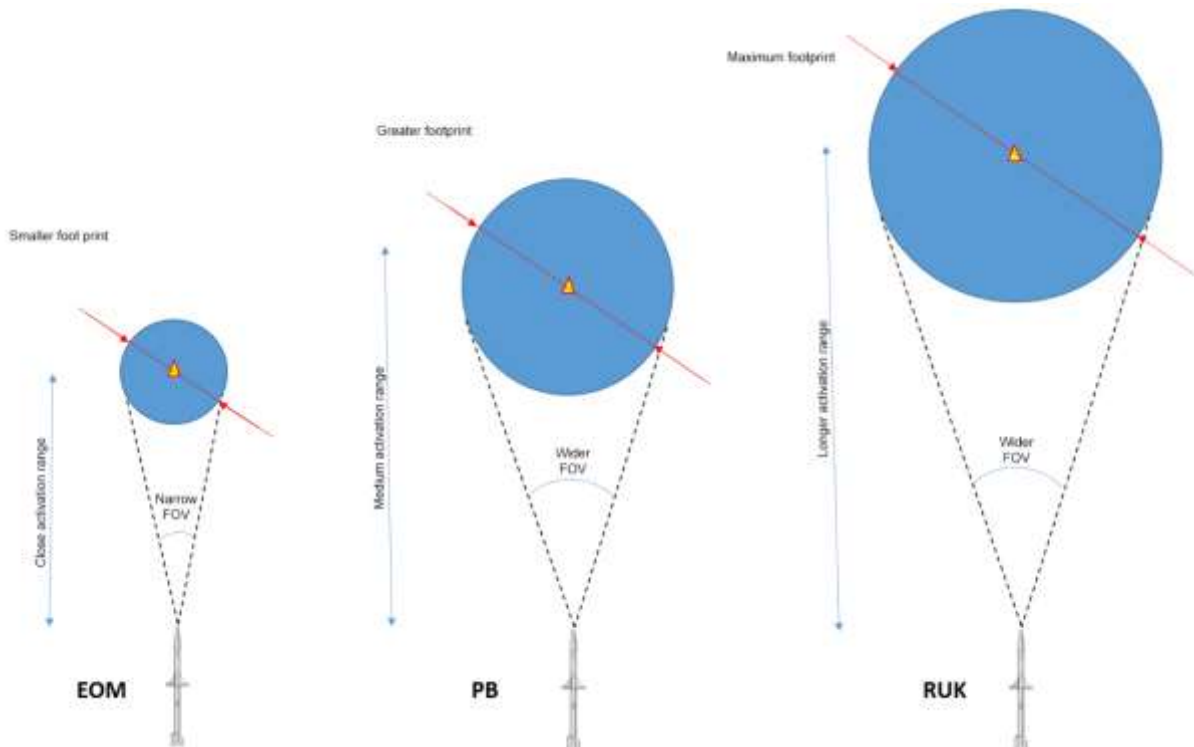

3.3.3.1 POS MODE EOM

EOM (Equation of motion) submode is the most used POS mode, because most of the time we have PPTs assigned to those threats and it is quite easy to target them precisely. It is also the default mode for the HARM Attack Display and may be used when the target location is PGM2 or less.

We will describe in detail POS EOM and then show the specifics of POS PB and POS RUK.

Remember, to use POS correctly you need a **threat type** and a **Position**. Both these need to be downloaded to the missile through the handoff and the steerpoint.

Threat handoff

In BMS, we have access to many threats spread into six tables. Tables are toggled from OSB2 on the WPN page.

Threats are located on the left edge (OSB 16-20) of the WPN MFD: 2 = SA2; 3 = SA3; 4 = SA4 etc....

Most Falcon threat and search radars are available through the six tables, infrared and optical targeting systems are obviously omitted.

The HARM threat tables program the AGM-88 with the computational data required for a successful AGM-88 launch across the various HARM modes.

The threat tables contain alpha/numeric characters to represent the different radars that may be encountered on SAM site suppression missions. You may also toggle through threat tables with TMS left when the WPN page is SOI.

Once the correct table is selected, you can handoff a threat to the missile. First select the HARM station and then depress the threat mnemonic OSB.

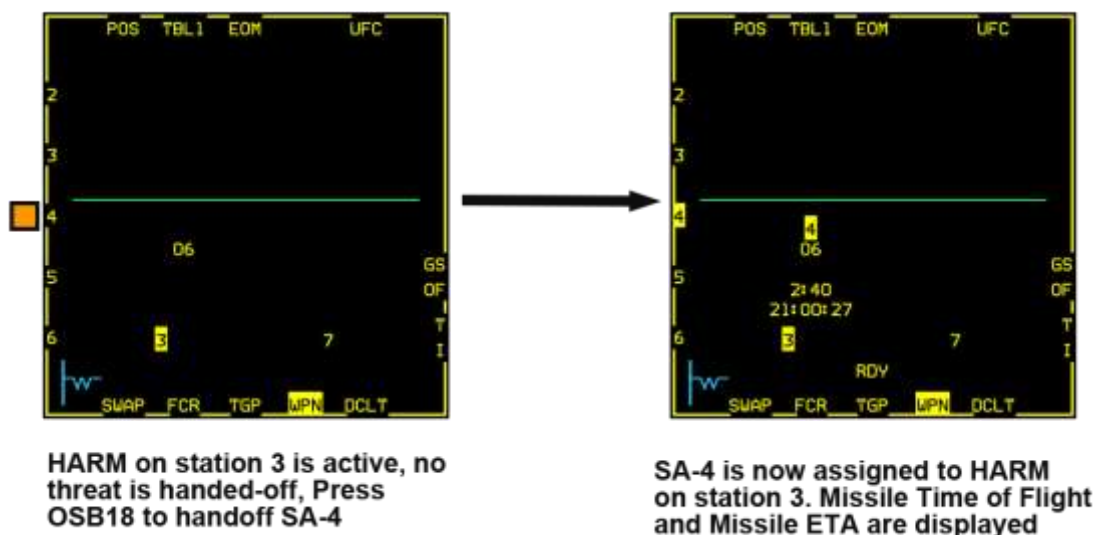

You can handoff another threat to another station by switching the weapon and repeating the procedure. In fact, you can pre-program each station with a specific threat, POS submode, and HARM mode. The WPN page will remember the handoff threat for each weapon.

Once the correct table is selected, you can handoff a threat to the missile. Select first the HARM station and depress threat mnemonic OSB.

Target Steerpoint

In POS mode you fire your missile at a steerpoint. The position is the Steerpoint of Interest from the UFC.

You cannot assign a different steerpoint to the missile than the one you have set in the UFC. As a consequence, always double check the HARM steerpoint on the POS EOM page before firing.

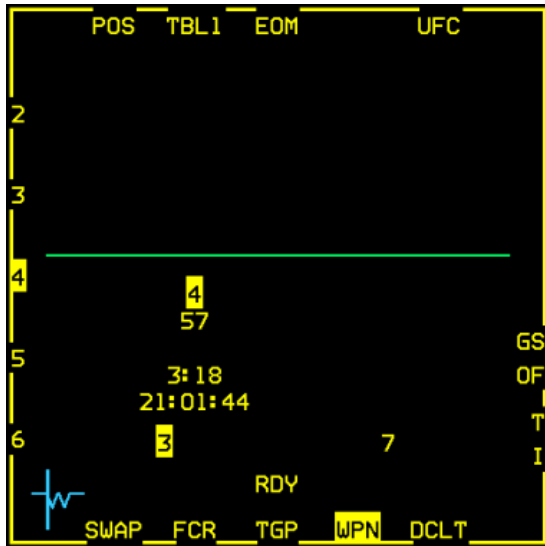

HARM on station 3 has been handed off with a SA3 threat and the current steerpoint of interest is PPT57. Once fired, the missile will fly to PPT57 and seek a Pat Hand radar in the vicinity of the steerpoint.

Please note: If for any reason you change the steerpoint in the UFC, you will also update the Harm steerpoint and begin a new handoff process!

Selecting a steerpoint from the UFC is probably basic knowledge. It can be done with the ICP #4 button (STPT) or by incrementing the STPT with the ICP arrows, but you will more usually fire at a PPT (pre-planned steerpoint) in this mode instead.

If the briefing was done correctly you should have a list of PPT numbers with assigned SAMs. You can then simply select the PPT as the Steerpoint of Interest in the UFC and it that location will automatically be assigned to the missile.

But the situation can become quickly confusing in flight because the HSD does not give you the PPT number but rather the threat linked to the PPT in the DTC. Similarly you might have multiple threats of the same type on your HSD and receiving an order to take out a SAM might be hard to resolve without receiving the PPT number.

It might be a good idea to select the Steerpoint of Interest straight from the HSD page rather than from the UFC.

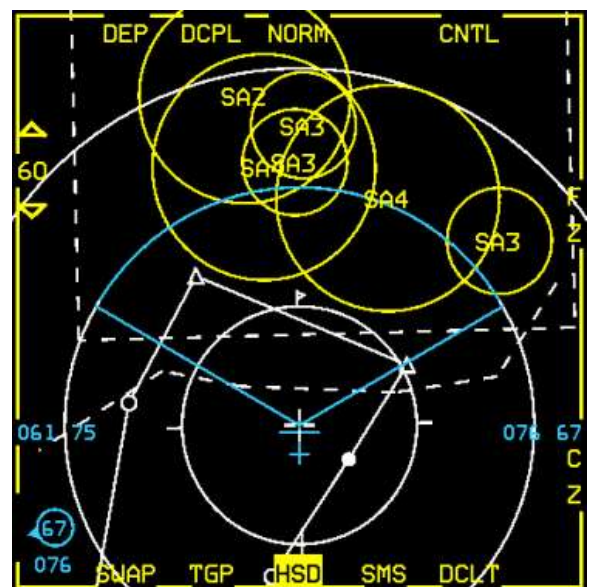

Simply make the HSD the SOI with DMS down and move the cursor to the PPT you want to select. Use pinky switch to zoom if required. Once over the PPT, depress TMS up to make that PPT the Steerpoint of Interest in the system. Confirm in the UFC and in the WPN page that the PPT number is assigned to the HARM.

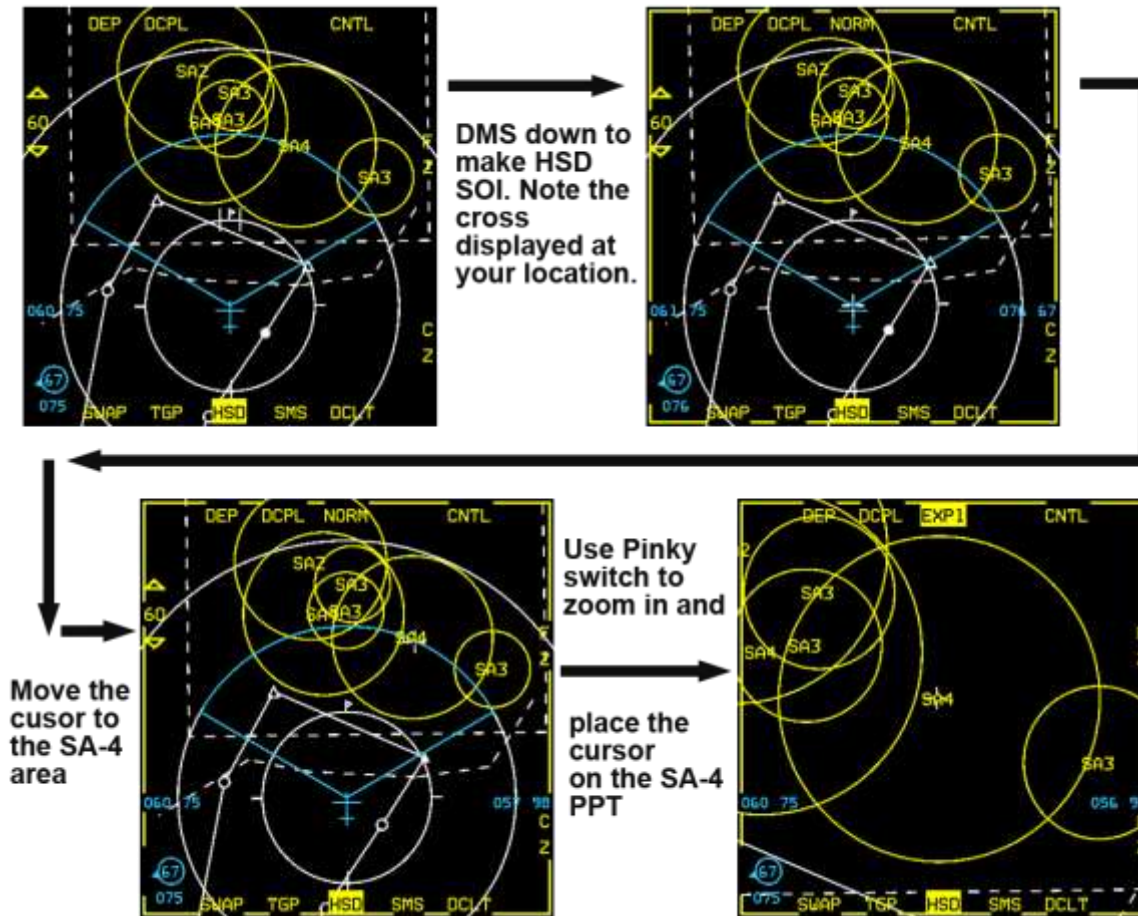

Depress TMS up to select that steerpoint as Steerpoint of interest.

Unzoom (pinky) and check UFC and WPN page to make sure that the Steerpoint switched to the SA4 PPT.

UHF	6	STPT	↕57
VHF	15		21:00:56
M12	4	6630	TIM T 94X

Toggleing between 2 pre-programmed HARMS (pre-launch)

- Use MSL step to select station.
- The missile will remember the handed off threat, the mode & submode but **not** the steerpoint. As a consequence, you should always double check the Steerpoint of interest before launching. You cannot have two different steerpoints assigned simultaneously.

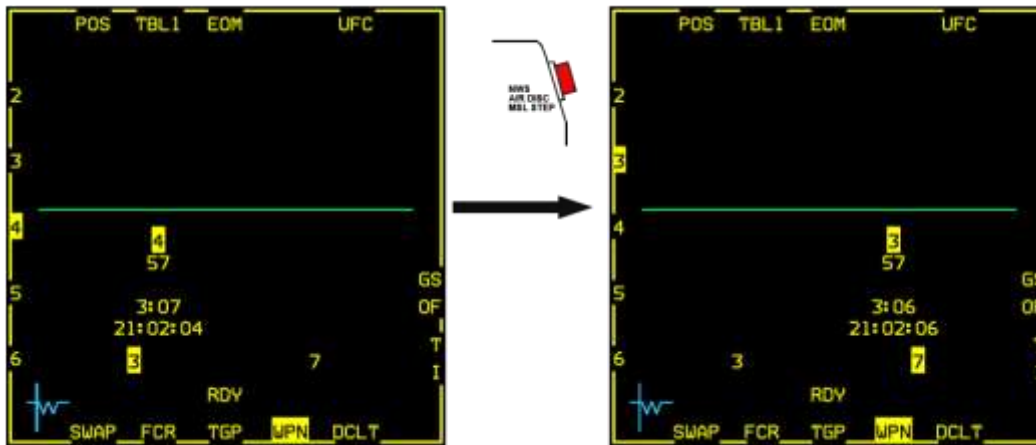

HARM on station 3 pre-programmed. (EOM, TBL1 (SA4) and threat location STP 57 = SOI).

HARM on station 7 pre-programmed. (EOM, TBL1 (SA3) and threat location STP 57 = SOI).

Timers

POS mode gives you a few pre-launch and post launch information beside the handed off threat and the position.

Pre-launch you get the missile time of flight (TOF) and the time when the missile will impact the threat (TOT)

Post launch you get the time until impact (TUI) only.

Timers are not displayed in RUK Submode.

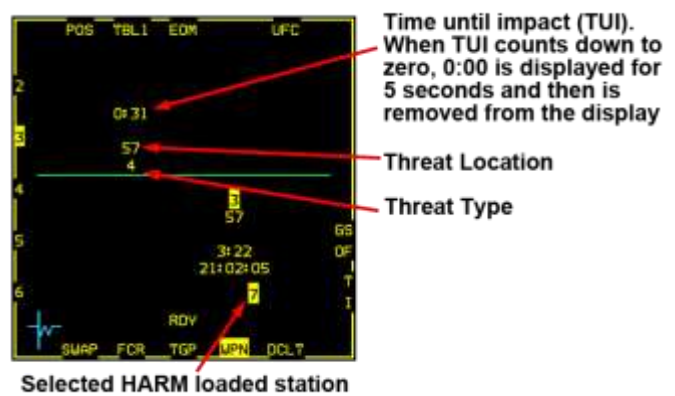
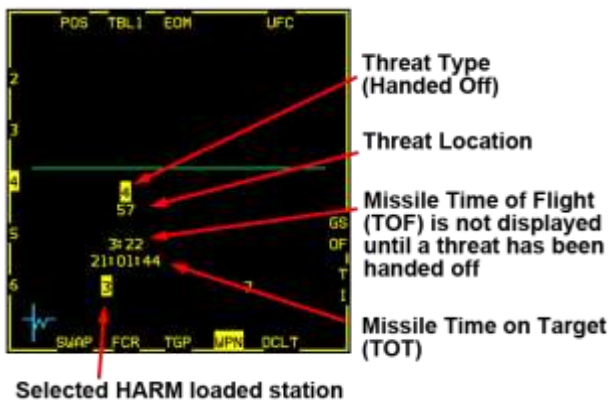

HUD Cues

With Master Arm enabled, you get the following HUD cues.

The HARM FOV box flashes when in range. This is the main cue for firing the missile.

HARM FOV box is smaller in EOM as the missile Field of view is smaller than in PB and RUK mode.

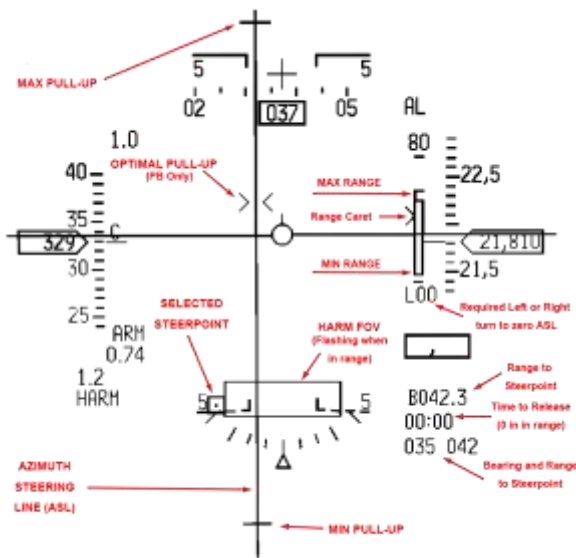

Azimuth Steering Line (ASL)

Function is similar to ASL in CCRP

Provide steering to direct missile bore sight line at TGT

Is displayed in POS regardless of threat handoff

Loft solution cues

Two loft solution cues are positioned on the Azimuth Steering Line (ASL). Disregard those for now as they are not implemented correctly.

A third cue is displayed in PB mode only and is located centrally on the ASL with two carets: It is the Optimal loft cue (see PB mode) Disregard as well.

The Loft solution cues are not available in RUK mode.

3.3.3.2 POS MODE PB

PB Stands for PRE-BRIEFED. POS PB is used for long range delivery with high confidence target location.

MFD: No difference from EOM sub mode, missile TOT and TOF are displayed.

HUD: Larger HARM FOV box. Optimal LOFT cues > < displayed.

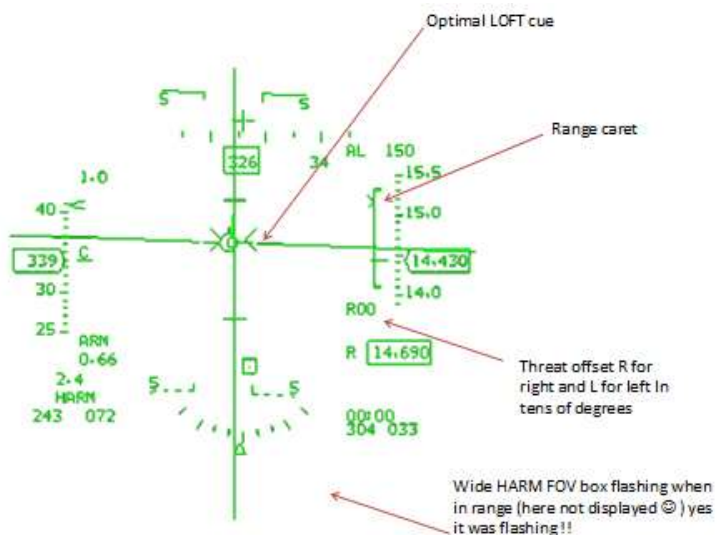
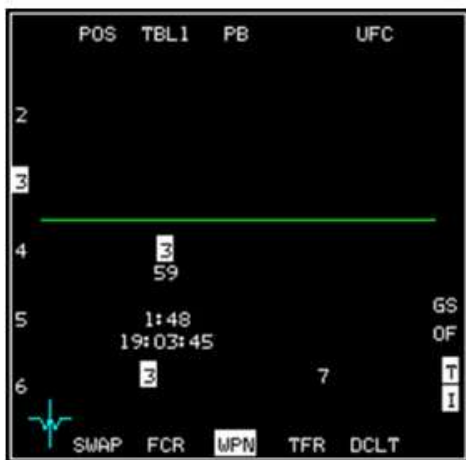

3.3.3.3 POS MODE RUK

RUK stands for RANGE UNKNOWN. The seeker activates at the maximum range from target with a wide Field of View. RUK is used when you have a specific threat painting you but have low confidence on its range. It can be useful in self-defence mode against a pop-up threat.

MFD: RUK submode does not display prelaunch TOF and TOT on WPN page (since range is unknown).

HUD: The Harm FOV box in the HUD is larger than EOM, no LOFT solution cues displayed, no required turns displayed.

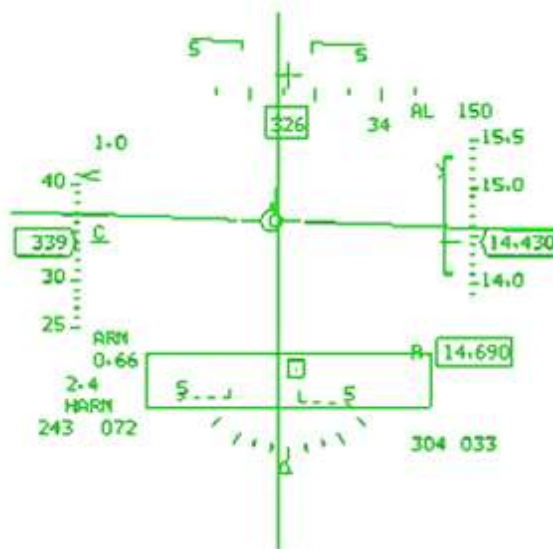
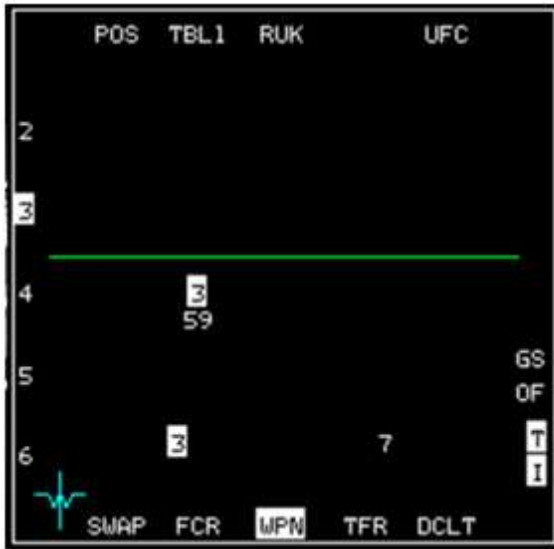

3.3.4 HAS Mode

HAS (HARM as Sensor) mode displays only emitting radars (up to 10). It is suitable for targets of opportunity. Contrary to POS mode, you do not need to know the threat position; emitting systems are displayed on the MFD.

As its name implies; the sensor is the missile. Once the last missile is fired, the HAS page is no longer accessible.

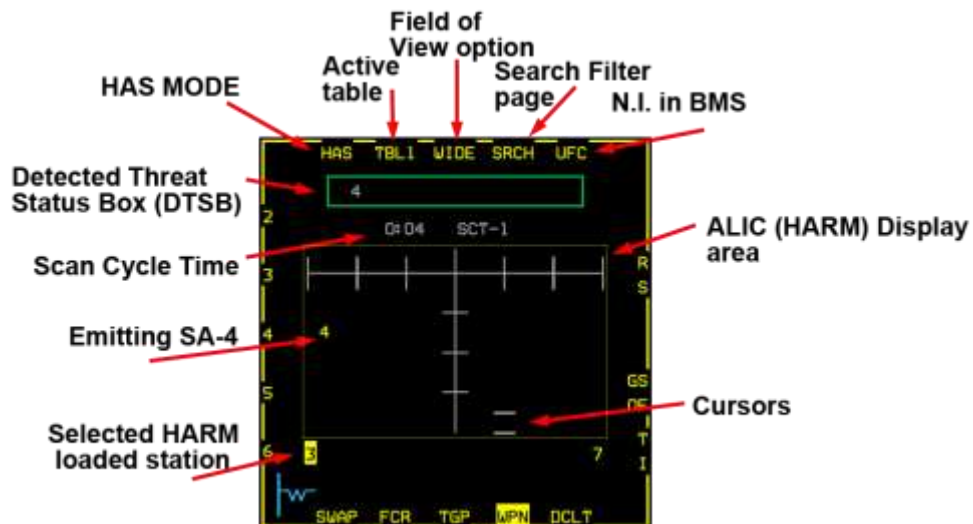

3.3.4.1 HAS Mode Controls

OSB 1 - Mode selection page (POS – HAS – DL)

OSB2 - toggles tables 1-6: Only threats from the selected table are visible on the HAS page!

OSB3 - HAS Field of View: WIDE (all direction, long range (altitude dependent)), CENTER (front only with half the WIDE range), LT (Left only), RT (Right only). Each time the FOV is changed the HAS page resets and threats disappear until detected again.

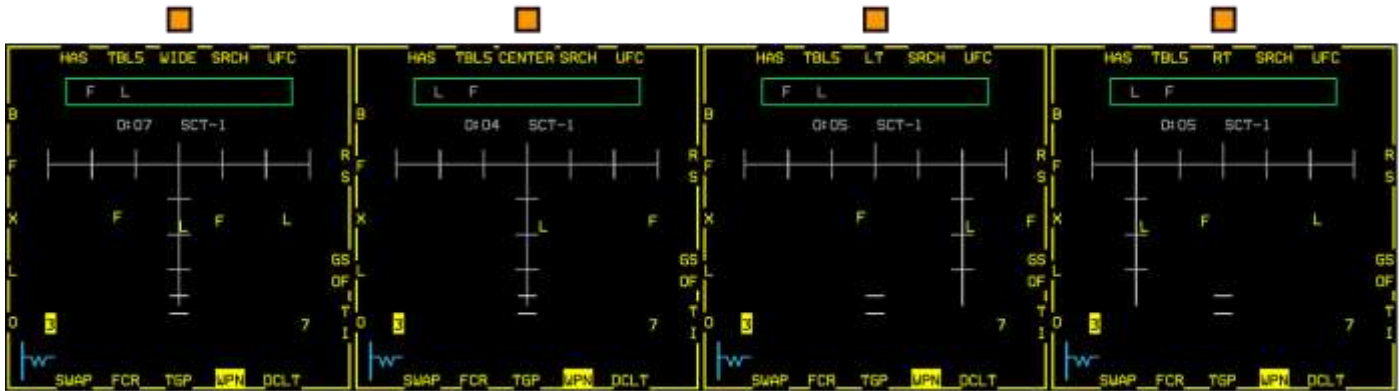

The contacts in the Aircraft Launcher Interface Computer (ALIC) are positioned from Elevation and Azimuth of the radar signals that are received by the HARM seeker.

The ALIC display is roll stabilized

3.3.4.2 HAS mode: Search Filter page

OSB 4 enters the search filter page, which allows you to narrow the threats from the tables. When you enter the SRCH page, all threats will be highlighted. Depress OSB2 to toggle between the 6 tables and depress OSB 16 to 20 to remove a threat from the search. Afterwards, only the desired threats will be highlighted, [SA-2 only, as shown].

Depress OSB1 to display the HAS page once set.

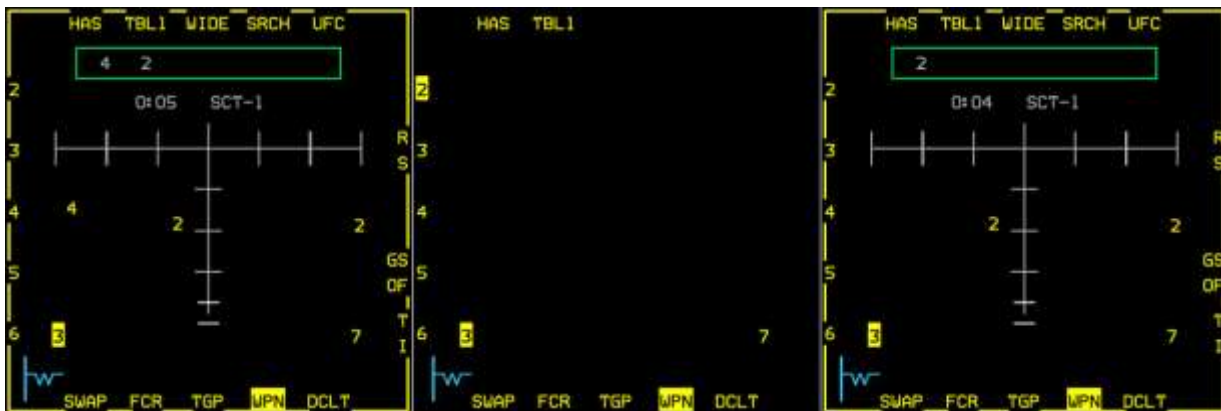

3.3.4.3 HAS mode: Handoff

To handoff a threat in HAS mode make the WPN page SOI and move the cursor over the threat. Select it with TMS Up.

Note the other emitting stations remain displayed in the DTSB but not in the display area.

To unselect a threat, use TMS down and the video will revert to the normal scan cycle.



HAS Search View, Wide FOV

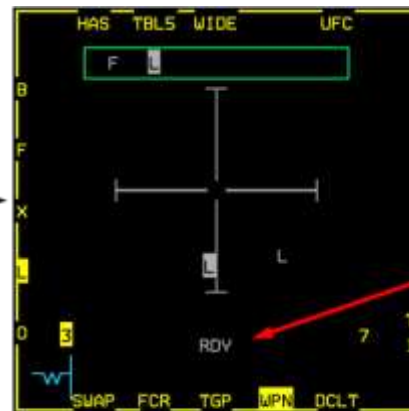

Missile boresight view, responds to aircraft pitch, roll and azimuth changes

RDY displays when the handoff is complete

Handoff takes a few seconds. RDY is displayed above OSB 13 when handoff is complete. Missiles fired before the handoff is complete will probably miss.

3.3.5 HARM Attack Display (HAD)

The AN/ASQ-213 HARM Targeting System (HTS) pod can be loaded on USAF F-16C/D Block 40/42 & 50/52 aircraft even if HARMs are not carried as part of the loadout.

The HTS (HARM Targeting System) pod displays an overview of discovered threats on the battlefield and gives the pilot the capability to employ the AGM-88 HARM missile in a dynamic threat environment. It can autonomously detect, identify and locate radar guided threats at long ranges and displays the target location to the pilot for HARM designation and firing.

Note: Pods are independently manually selectable from the LOADOUT screen. AN/ASQ-213HTS pods will automatically be fitted to the left chin station of compatible USAF F-16C/D Block 40/42 & 50/52 aircraft if SEAD missions are selected.

Note also: AN/ASQ-213 HARM Targeting System (HTS) implementation in BMS is merely a representation of reality. The real system is highly classified and may work differently.

The MFD display for using HTS is now called the HARM Attack Display (HAD). The HARM SMS page and main MFD menu page are depicted below.

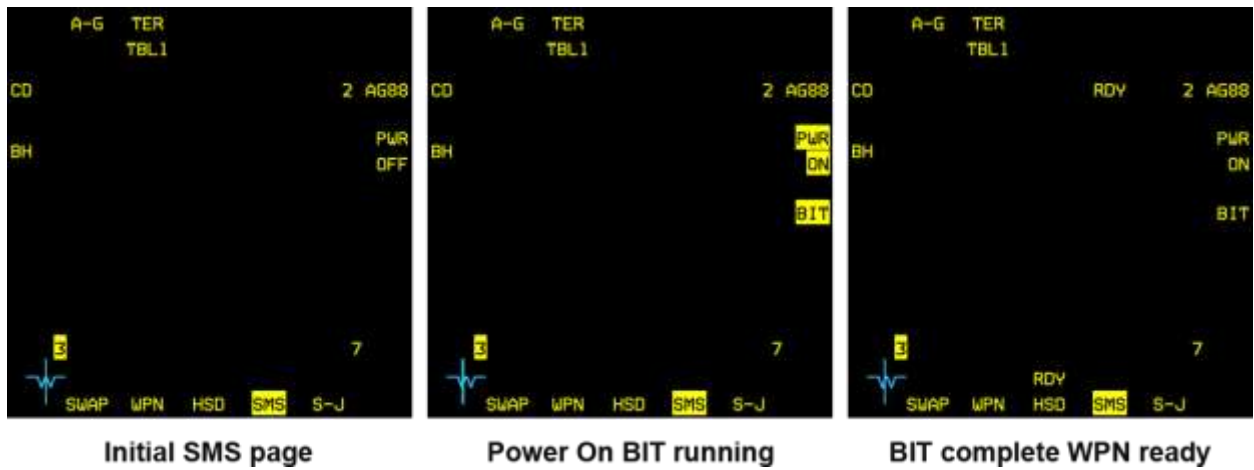

Figure 104 HARM SMS page

The HAD is selected from the main MFD menu by pressing OSB 2 (HAD label). The HAD may be selected in any master mode but it can only be operated in A-G master mode with HTS and AGM-88s loaded.



3.3.5.1 HAD Display

The HAD shares many common display features as the HSD.

- Steerpoints & flight plan
- PPTs and threat circles
- Datalink contacts
- Bullseye information
- Range Rings
- STPT Lines



HAD cursor movement and expanded FOV (OSB 3 or pinky switch) options are similar to the HSD as well. The pilot may select the HAD range (HAD as the SOI) by slewing the cursors up and down the display to bump range or by pressing OSBs 19 and 20.



In addition to the standard HSD display, the HAD displays specific information.

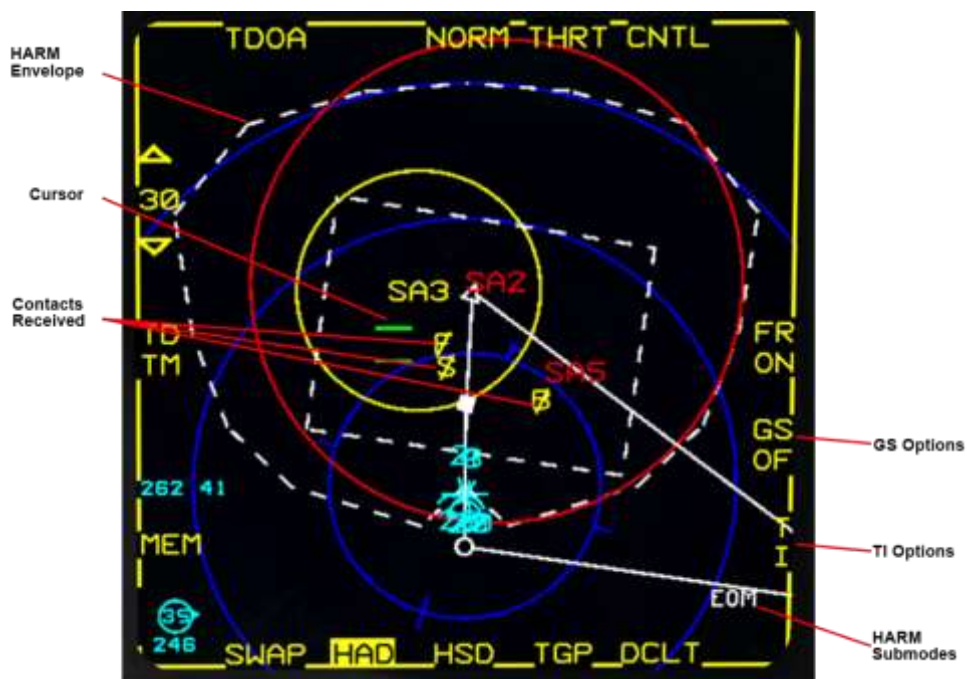
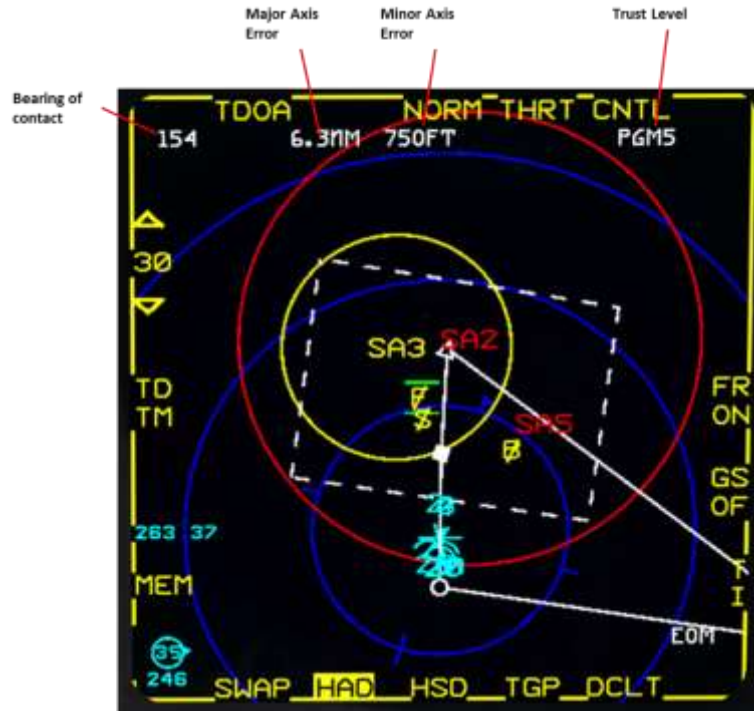

Figure 105 HAD MFD page

When contact is under Cursor, additional information is displayed at the top of the MFD page.



3.3.5.2 HTS Principle and operation

The HTS/HAD is very different from HAS. Contrary to the HAS, when fired on a HAD locked target, the HARM does not track the target with its own seeker from the start. The HAD is used to handoff the threat and the estimated position of the target. **The HARM is actually fired in POS mode**, flying to the estimated handoff position before actually activating its own seeker, exactly like the POS mode.

It is therefore critical that the estimated position of the threat from the HTS be computed with the greatest accuracy.

However, the HTS is not an active device, it is a passive device that logs the elevation and azimuth of radar sources. As such, there is no possibility for the HTS to accurately compute the range of the emitter from a single ping. It could be a weak emitter close or a strong emitter far away. An additional error comes from the HTS antenna resolution.

Given the size of the search footprint discussed previously, the location of the emitter must be accurate or the HARM will totally miss the target area.

In order to reduce the position error, the HTS keeps track of the signal's bearing for every ping received and by triangulation, eventually, improves the resolution. The more azimuth deviation between two pings, the quicker the error is reduced.



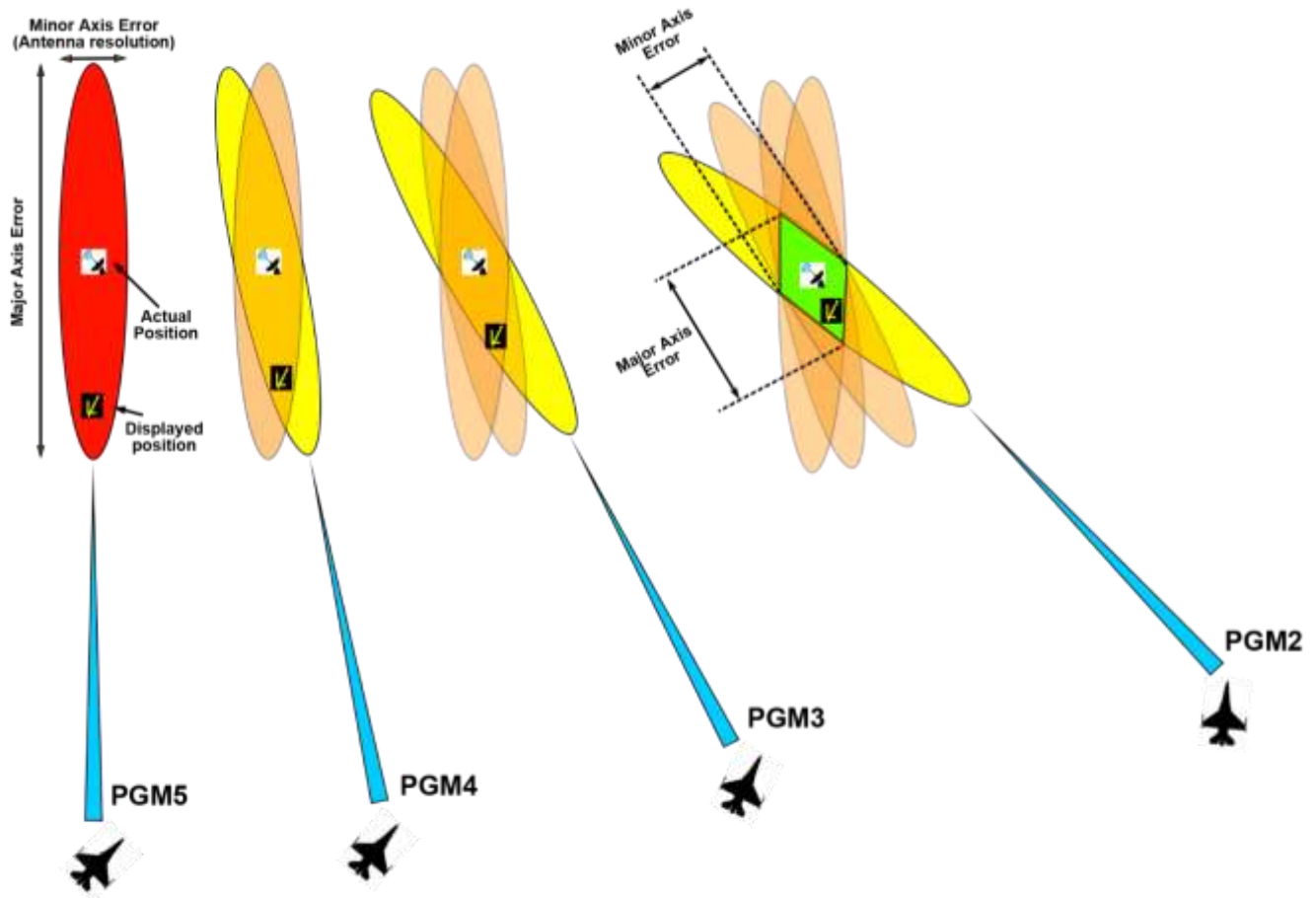

Think of the solution error as an oval, the length is estimated by the signal strength and the width is the HTS antenna width; the target can be anywhere in that oval. The "Major Axis" number represents the size of the longest axis of the error oval (length) in NM and in Ft below 1000 ft. The "Minor Axis" number represents the size of the smallest axis of the error oval (width) in NM and in Ft below 1000 ft.

The Precision Guided Munition (PGM) index represents the level of trust in the accuracy of the contact. The lower the index, the greater the accuracy. Firing a HARM with a PGM5 could result in a miss by several miles. It is recommended that you do not fire until PGM2 has been achieved.



The HTS does not provide any information on the Radar emitter status (searching/ tracking/ guiding).

Detected emitters are coloured as follows:

-  Emitter not active but detected once or Emitter behind the 3-9 line
-  Emitter active
-  Emitter Selected
-  Emitter Handed off

The handoff process is automatic after TMS UP and takes a few seconds.

NOTE: Firing a HARM before handoff process is completed will result in an inactive missile, equivalent to a jettisoned store.

The HARM WEZ/Footprint is based on Rmax of the AGM-88 and will increase/decrease in size according to your speed and altitude. If the HARM WEZ is greater than the selected display range, the lines will be dashed.

THE HARM WEZ footprint is dependent on the HARM Sub mode.

The HARM Sub Mode is automatically selected between RUK and EOM depending on the PGM index status.

Manual override is possible with TMS up Long.

As the HARM is actually fired in POS mode, the GS and TI options are available with identical behaviour to POS mode.



Target lock is possible with the HAD page after all ownship HARMs have been fired. This allows you to direct your AI wingmen to attack based on either a lock on your HAD page or hovering over a threat with the HAD page cursor, provided the HAD page is SOI.

3.3.6 New GS (Geographic Specificity) and TI (Target Isolate) implementation

Both options have been implemented in 4.35.

3.3.6.1 Geographic Specificity

Geographic Specificity (GS) options are available in POS and HAD modes.

The GS option allows you to restrict the HARM seeker to a smaller geographical area around the selected steerpoint. (I.E. a smaller circle centred on the selected steerpoint in POS or target in HAD)

The GS option overrides all other seeker options.

OSB 9 cycles through the GS options. The GS mnemonic highlights when GS is selected and every change will restart a handoff process. Only GS Default (DE) is implemented (GS MP is the same as GS DE).

With GS active, the diameter of the restricted search area is dependant on the distance at launch. The greater the distance, the larger restricted area.



Unrestricted



Geo Restricted



Geo Restricted

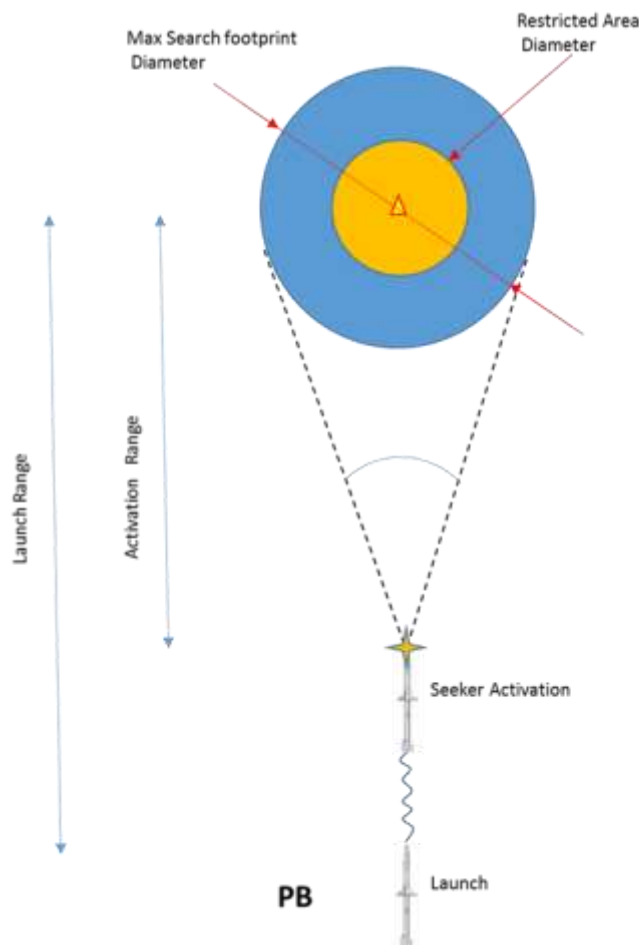

3.3.6.2 *Target Isolate*

Target Isolate (TI) options are available in POS, HAS, and HAD modes

TI allows you to select combinations of FLEX and GLIDE actions as described below:

3.3.6.2.1 Target Isolate - FLEX

This instructs the seeker to search for alternative threats if the primary handoff threat is not active. When enabled, the missile will start searching for alternate threat emitter types. A HARM will FLEX when it has reached the range at which it should have acquired the primary threat type but has not yet acquired it.

The seeker will search for active radars, filtering out search radars. GS restrictions will be applied to the search footprint

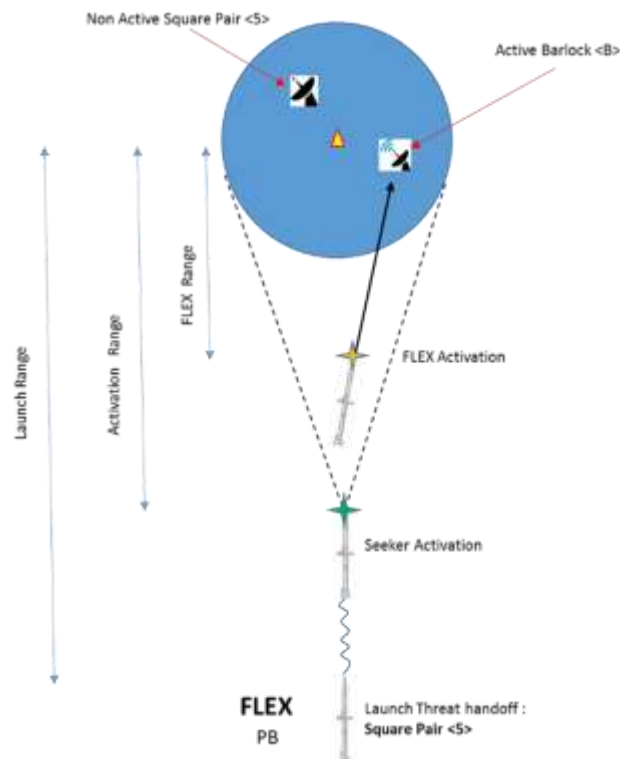

3.3.6.2.2 Target Isolate - GLIDE

Allows the missile to change its flight profile by maximising its time aloft to increase the chances of finding a target.

Two glide modes are possible and allow the HARM to be used as suppression (SEAD) or destruction (DEAD).

Loss of Track Glide (LOTG)

If the primary threat was detected and then lost, LOTG allows the missile to enter a shallow dive to optimize the time over target. If the flight path is not flattened, the Inertial Navigation System drift and limited blast radius make it very unlikely to hit the target. Therefore, it is more effective to maximize the time of flight while awaiting the threat to come live again (or, if in FLEX mode, another threat is detected).

When entering into LOTG, the HARM seeker goes to wide FOV to maximize the chance of finding the threat.

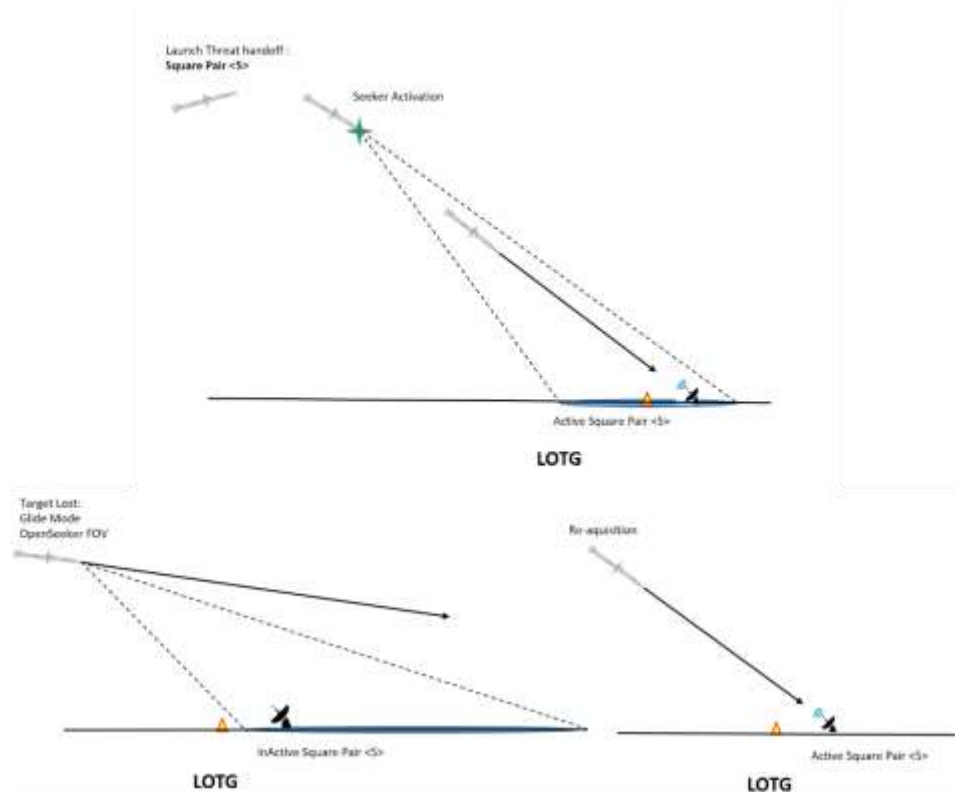

Equations of Motion Glide (EOMG)

If primary threat has not been detected when reaching a certain range, EOMG allows the missile to enter a shallow dive to optimize the time over target. This maximization of the time of flight increases the chance that the threat is suppressed or destroyed in the event it radiates, or another threat is detected (if the FLEX option is enabled).

When entering into EOMG, the HARM seeker goes to wide FOV to maximize the threat detection. EOMG can thus enable a search for targets away from the handoff steerpoint, due to this enlarged footprint.

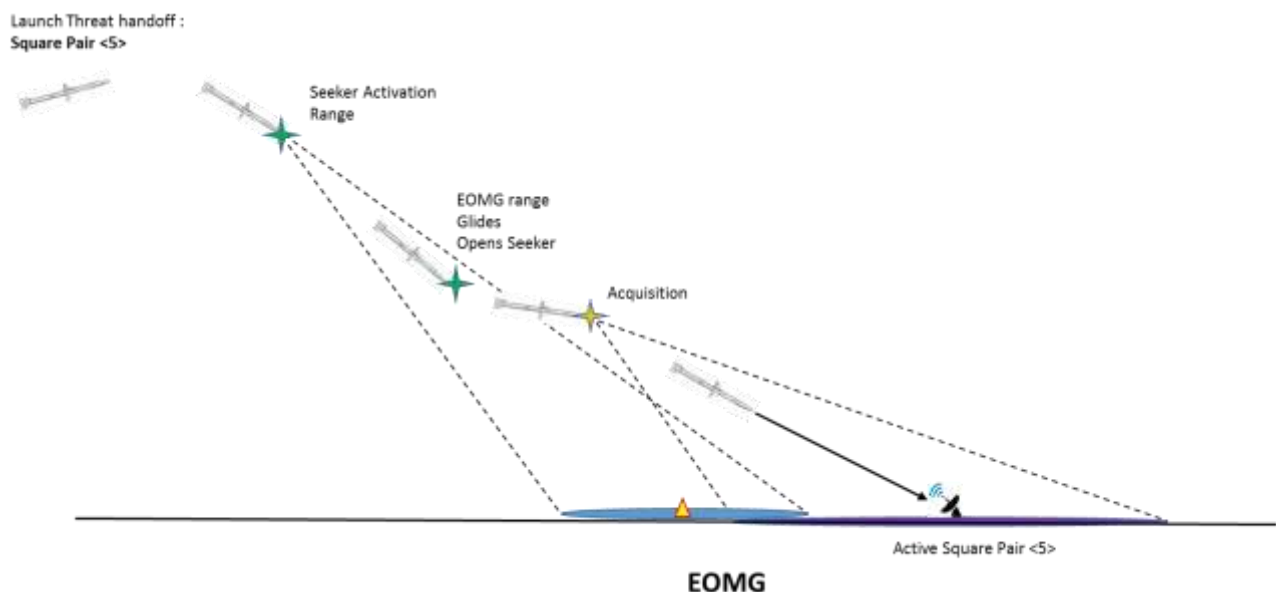

OSB 10 cycles through TI options.

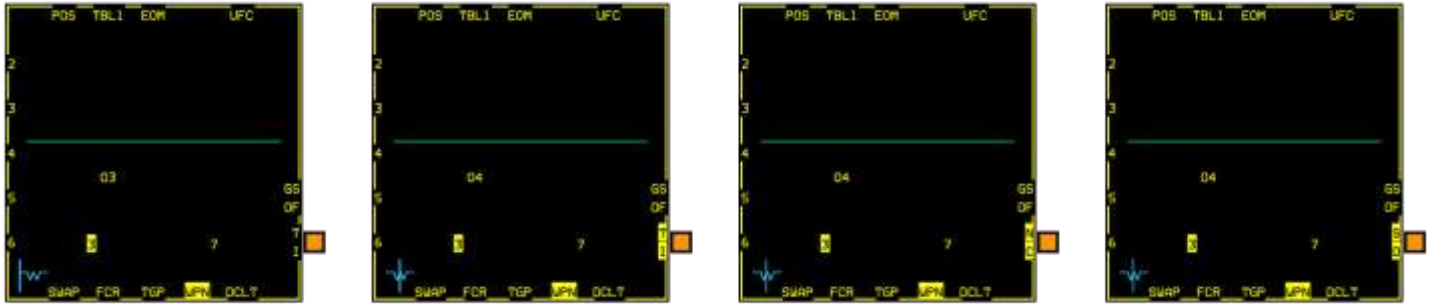

MODE	TARGET ISOLATE (NO FLEX)	GLIDE	BEHAVIOR
TI	OFF	ON	Missile will flex Missile will glide
TI	ON	ON	Missile will not flex Missile will glide
OT	OFF	OFF	Missile will flex Missile will not LOTG but will EOMG
OT	ON	OFF	Missile will not flex Missile will not glide

3.3.7 HOTAS Controls Summary

- Cursor enable – Toggles between POS and HAS modes (WPN page needs to be SOI).
- Cursors: Move captain bars in HAS/HAD display.
- TMS Up – Handoff the threat in HAS/HAD.
- TMS Up LONG - POS/HAD: cycles HARM Sub Modes
- TMS down – Deselects the currently selected threat in HAS/HAD.
- TMS Right
 - HAS: Selects first valid threat; a 2nd TMS Right steps to the next threat.
 - POS: Cycles threats from the selected Threat Table
- TMS Left – Toggles between threat tables.
- Pinky Switch
 - POS: Cycles the HARM Sub Modes
 - HAS: Cycles the FOV.

3.4 INERTIALLY AIDED MUNITIONS

This section describes the mechanization functions of the Joint Direct Attack Munition (JDAM), Joint Standoff Weapon (JSOW), Wind-Corrected Munitions Dispenser (WCMD) and Small Diameter Bomb (SDB) weapons. Functions include Multifunction Display Set (MFDS) and Head-up Display (HUD) control and display features, weapon power-up, initialization, built in test, station and weapon status, weapon type and station selection and weapon targeting. Unique mechanization differences among the weapons are addressed as they arise in the descriptions. Inertially-aided munitions (IAMs) are air-to-ground weapons that include an Inertial Navigation System (INS), or a combination of INS and Global Positioning System (GPS) to precisely guide the weapons to their targets. Each of these weapons provides improved standoff capabilities and relaxed release envelopes. IAMs may be loaded on stations 3 and 7 only. These are the only stations which support the wiring required for the data transfer between the aircraft and weapon.

3.4.1 JDAM

JDAM weapons are guided by an INS/GPS set contained within the weapon and are designated as Guided Bomb Units (GBUs). The current inventory of JDAM weapons includes the GBU-31(v)1/B, GBU-31(v)3/B, GBU-32(v)1/B and GBU-38/B based on the Mk-84, BLU-109, Mk-83 and Mk-82 bombs, respectively. JDAMs can be loaded onto the A-10C, AV-8B+, F-14, F-15E, F-16 and F-18.



Figure 106 GBU-31(v)1/B JDAM

3.4.2 WCMD

WCMDs are Cluster Bomb Units (CBUs) that include a tail kit containing an INS that is used to guide the weapon to an upwind dispense position to allow the submunitions to drift over the target (WCMDs do not contain a GPS). WCMD allows release within a launch envelope. With the WCMD tail kit, the CBU-87 Combined Effects Munition (CEM) becomes the CBU-103; the CBU-89 Gator becomes the CBU-104 and the CBU-97 Sensor Fused Weapon (SFW) becomes the CBU-105. WCMDs can be loaded onto the A-10C and the F-16.



Figure 107 CBU-105 SFW

3.4.3 JSOW

JSOW is an unpowered, glide weapon that has deployable wings and is guided by a self-contained INS/GPS set. JSOW comes in two variants, the AGM-154A and the AGM-154C and may be launched from standoff ranges beyond 20 NM at low or high altitudes in day or at night in all weather conditions. The warhead of the AGM-154A consists of 145 BLU-97/B Combined Effects Bomb (CEB) submunitions. These bomblets have a shaped charge for armour defeating capability, a fragmenting case for material destruction and a zirconium ring for incendiary effects. It is most effective against non-moving targets. The AGM-154C uses a penetration warhead and is most efficient against hard targets like runways, bunkers and hardened aircraft shelters. JSOWs can attack pre-planned targets downloaded from the DTE (includes associated waypoints to the target), targets tracked by onboard aircraft sensors, targets provided by datalink, or targets entered by the pilot on the UFC. The JSOW weapon does not require the aircraft to fly directly at the target, but allows release within a launch envelope. JSOWs can be loaded onto the F-15E, F-16 and F-18.



Figure 108 AGM-154A JSOW

3.4.4 SDB

SDB is an unpowered, glide weapon that has deployable wings and is guided by a self-contained INS/GPS set. Small diameter bombs may be launched from standoff ranges beyond 30 NM at low or high altitudes in day or at night in all weather conditions. The GBU-39 is most effective against non-moving targets. The GBU-39 uses a high explosive warhead and is most efficient against soft-skinned targets like air defence vehicles, artillery pieces, radars and communications towers, fuel tanks, etc. SDBs can attack pre-planned targets downloaded from the DTE, targets tracked by onboard aircraft sensors, targets provided by datalink, or targets entered by the pilot on the UFC. The SDB weapon does not require the aircraft to fly directly towards the target, but allows release within a launch envelope. SDBs can be loaded onto the A-10C, F-15E and the F-16.



Figure 109 GBU-39 SDB

3.4.5 Laser JDAM

Laser JDAM expands the capabilities of JDAM as it allows dual guidance with a Precision Laser Guidance Set (PLGS) added to JDAM guided bombs. The GBU-54 is based on the Mk-82 500lb GP bomb.

Laser JDAM can be released to fly independently to the target like a JDAM, or guide to any stationary or moving target by tracking a laser spot like a Laser Guided Bomb. Laser JDAM does not require continuous lasing if the target is stationary, because unlike LGBs LJDAM extracts coordinates from the laser spot position, so even lasing for a few moments will cause the bomb to change target towards the laser spot position and it will keep heading towards the updated position without the need to lase continuously.



Figure 110 GBU-54 Laser JDAM

Note: the Laser JDAM control page contains 2 subpages. The subpages can be toggled via OSB 9.

3.4.6 IAM SMS Pages

JDAM, JSOW and WCMD base pages and their associated control pages that are described in figures below. There are several common functions shared by all IAMs as well as unique functions for each weapon.

3.4.6.1 JDAM

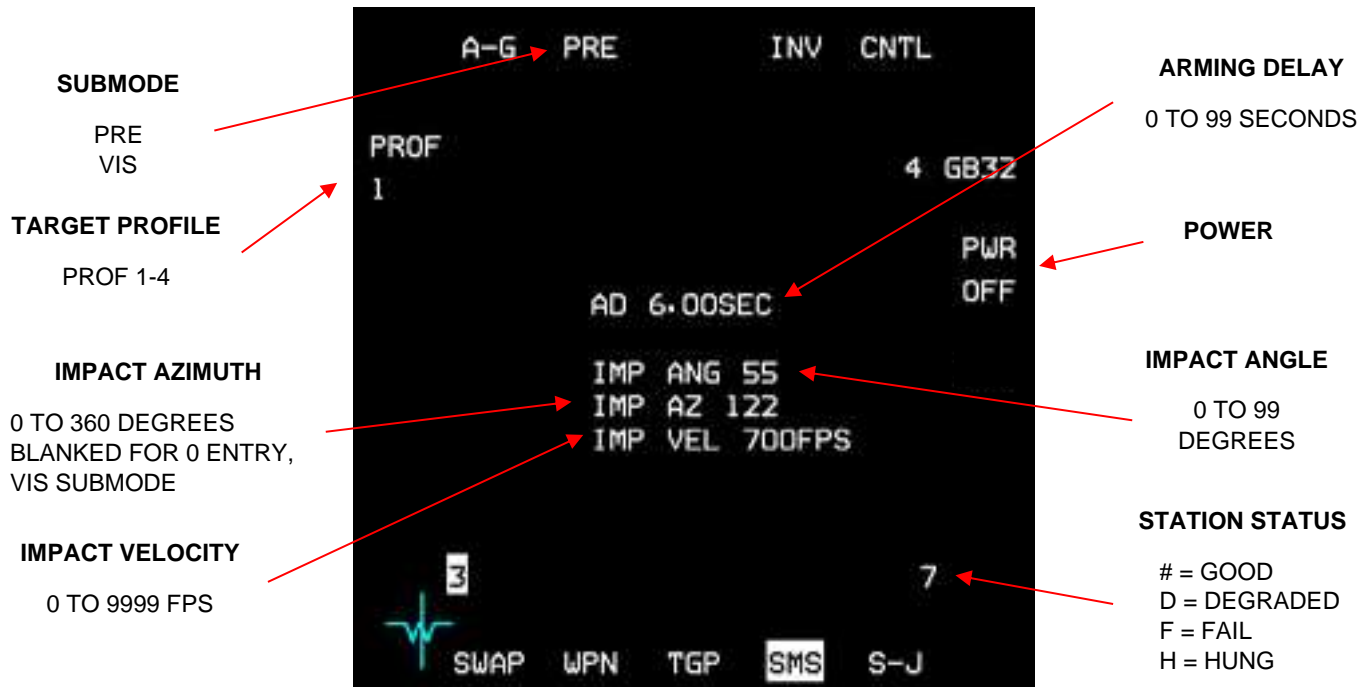

Figure 111 JDAM SMS base page



Figure 112 JDAM SMS control page

3.4.6.2 WCMD

IMPACT OPTION

SINGLE
SIDE BY SIDE
TANDEM

IMPACT SPACING

0 TO 9999FT
NOT DISPLAYED
WITH SINGLE
OPTION

BURST ALTITUDE

ATTACK AZIMUTH
0 TO 360 DEGREES
BLANKED FOR 0
ENTRY, VIS SUBMODE



TARGET WIND BEARING & SPEED
(N/I)

WIND TYPE

MP = MISSION
PLANNING WIND
SY = SYSTEM WIND
PI = PILOT
ENTERED WIND
(N/I)

ARMING DELAY
0 TO 99 SECONDS

Figure 113 WCMD SMS base page

ATTACK AZIMUTH

BEARING FROM
MAGNETIC NORTH, 0
WEAPON GOES
DIRECTLY TO TARGET

ARMING DELAY
0 TO 99 SECONDS

BURST ALTITUDE

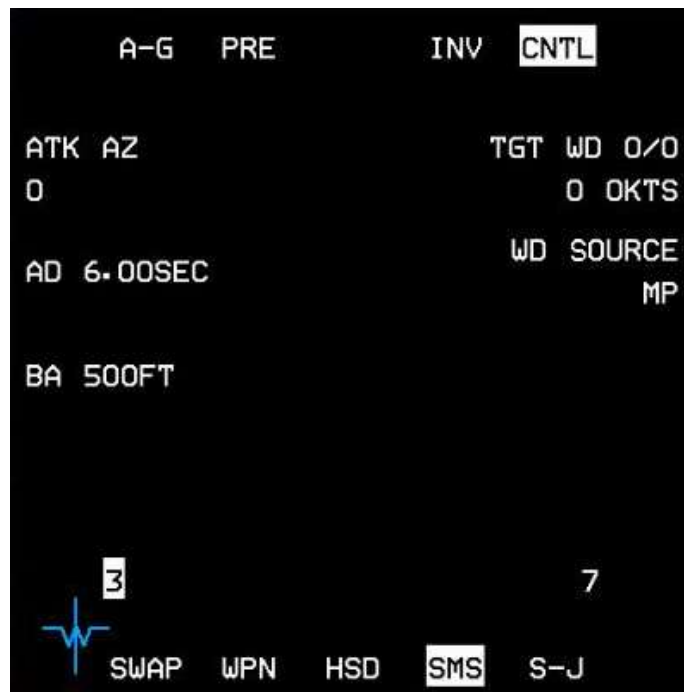

TARGET WIND BEARING & SPEED
(N/I)

WIND TYPE

MP = MISSION
PLANNING WIND
SY = SYSTEM WIND
PI = PILOT
ENTERED WIND
(N/I)

Figure 114 WCMD SMS control page

3.4.6.3 JSOW

IMPACT OPTION

SINGLE

SIDE BY SIDE

TANDEM

IMPACT SPACING

0 TO 9999FT

NOT DISPLAYED
WITH SINGLE
OPTION

**END GAME
ENTRY ALTITUDE**

ONLY WITH
AGM154A
SELECTED

RANGE ON BEARING



ATTACK AZIMUTH

0 TO 360 DEGREES

BLANKED FOR 0
ENTRY, VIS SUBMODE

Figure 115 JSOW SMS base page

ATTACK AZIMUTH

0 TO 360 DEGREES

BLANKED FOR 0
ENTRY, VIS SUBMODE

**END GAME
ENTRY ALTITUDE**

ONLY WITH
AGM154A
SELECTED

RANGE ON BEARING



Figure 116 JSOW SMS control page

3.4.6.4 SDB

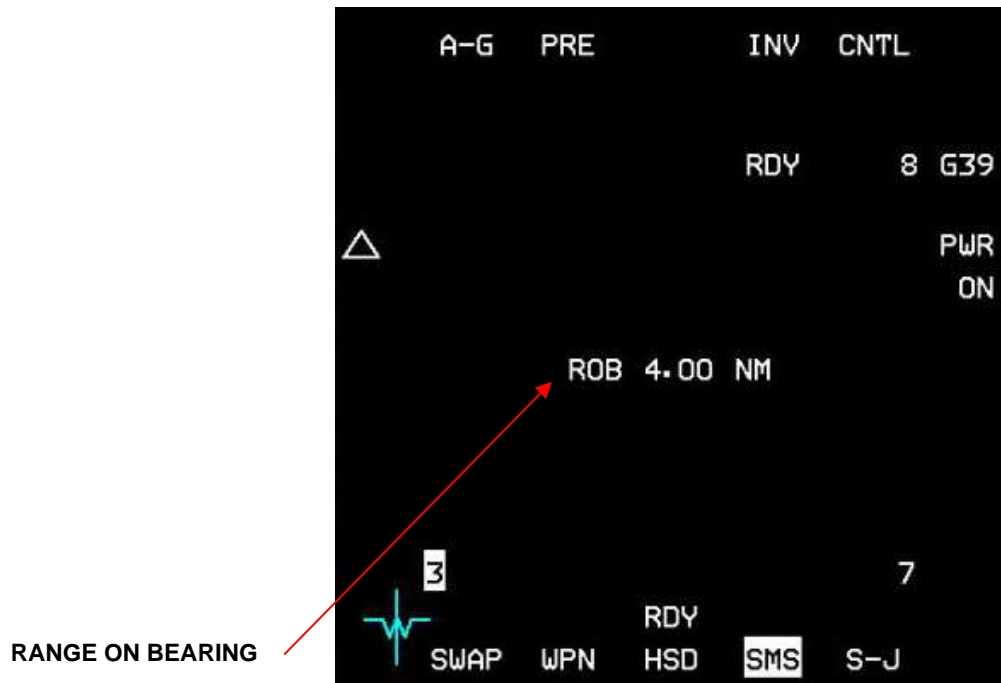

Figure 117 GBU-39 SDB SMS base page

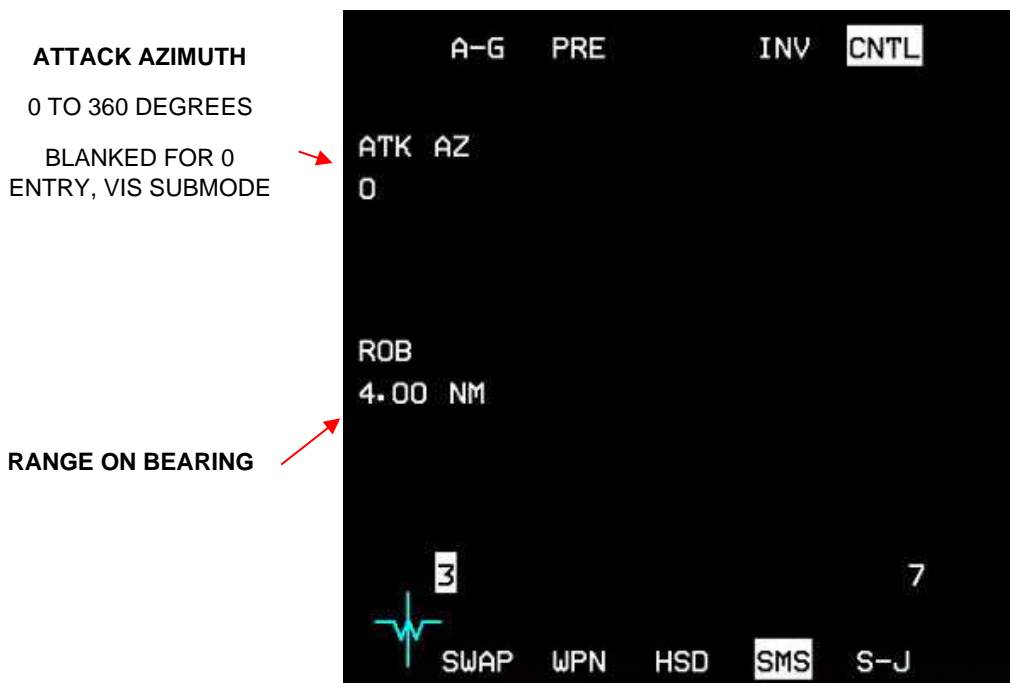

Figure 118 GBU-39 SDB SMS control page

3.4.6.5 LJDAM

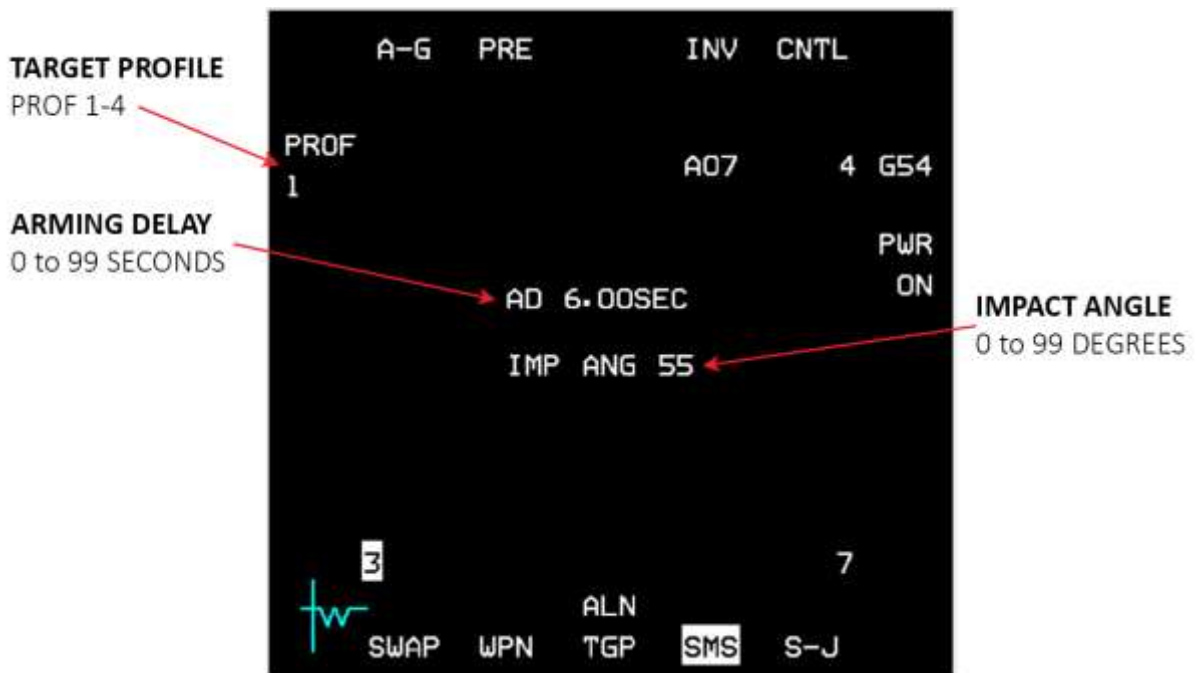

Figure 119 Laser JDAM SMS base page

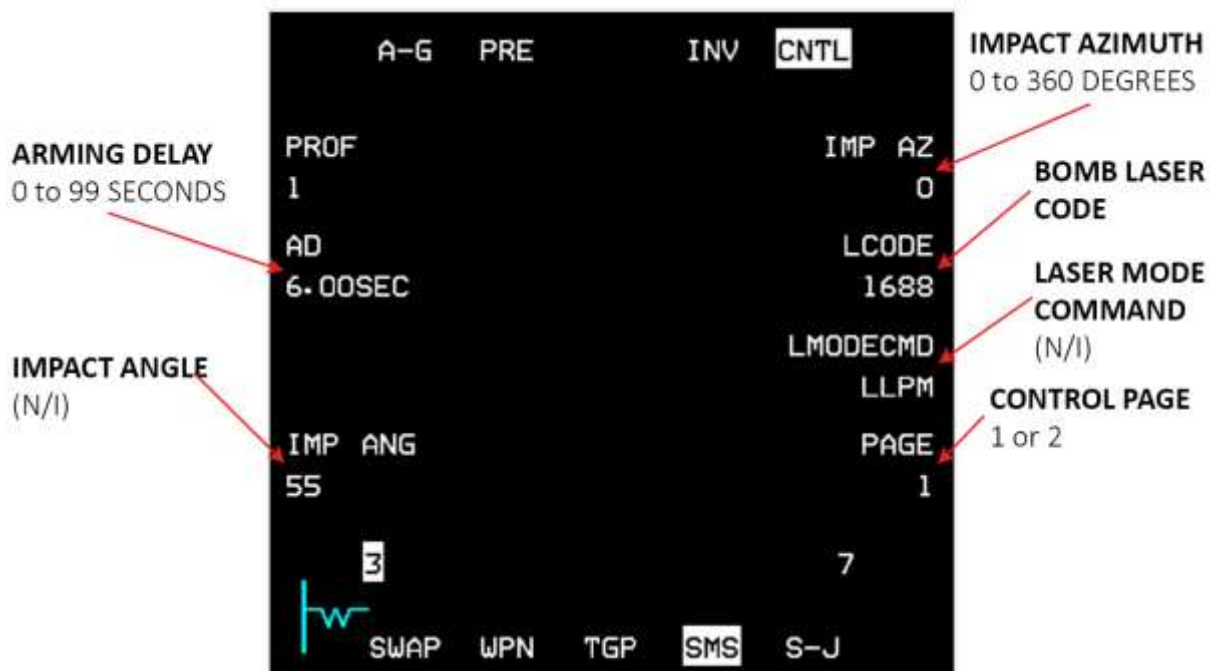

Figure 120 Laser JDAM SMS control page

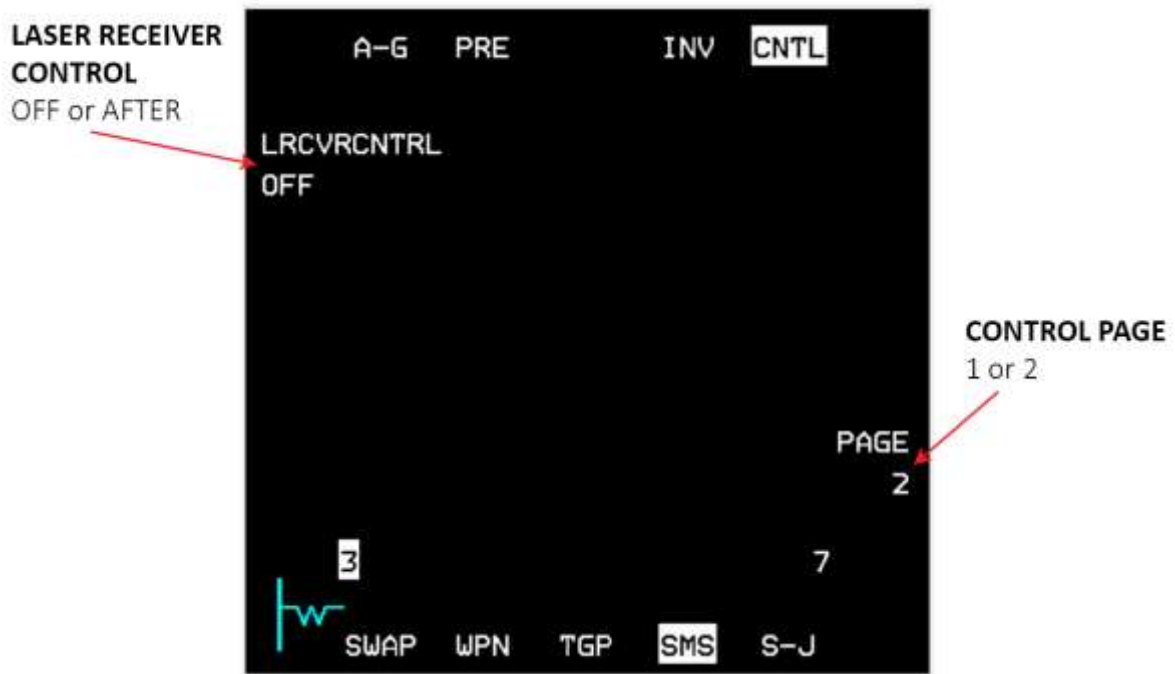

Figure 121 Laser JDAM SMS control page 2

3.4.6.6 **Power**

IAMs are powered on by depressing and releasing (D&R) OSB 7 on the JDAM, JSOW, and WCMD SMS weapon base pages. Power is provided to all IAMs and is maintained until launch or manual deselection of power (D&R OSB). Before applying power at any station, IAM weapon power at the selected station should be allowable. IAM weapon power is allowable at a station when a store is present and the station is not hung.

3.4.6.7 **Station Status Reporting**

The station status indicates the operational status of the IAM loaded at each respective station. Station status is displayed adjacent to OSB 10 (station 7) and OSB 16 (station 3) on the SMS base and control pages. The station number ("7" at OSB 10 or "3" at OSB 16) indicates a "good" weapon status. The station numbers are replaced with D, F, or H for stations having malfunctioning weapons.

- # - Station number indicates a good weapon status
- D - indicates a degraded weapon.
- F - Indicates a failed weapon. This may indicate an MMC communications failure between weapon/station and the MMC or an internal weapon failure.
- H - Indicates that the weapon is a "Hung" store. An "H" would typically be displayed after a weapon release had been unsuccessfully attempted.

3.4.6.8 **Display of IAM Warm-Up and Alignment Status**

After the automatic BIT on the IAM weapon(s) has been performed, mass data transfer (MDT) occurs for all IAMs (except for the wind corrected munitions dispenser (WCMD) which does not contain a GPS unit). All mission planned weapon data is automatically downloaded from the DTE to the weapon without pilot interaction. The MDT process is performed sequentially for all of the IAM stations that are powered on (a power on command commands power to all IAM loaded stations that meet power on requirements of a positive quantity and a store present). INT status is displayed during MDT.

After initial BIT and MDT, IAM warm-up may take up to three minutes. During this period the weapon navigation solution quality goes from unsatisfactory to marginal and on until the weapon alignment becomes RDY. Status is only provided when a weapon is loaded; no emulation is provided with zero quantity loaded.

After weapon initialization has been completed, the transfer alignment (TXA) quality countdown will begin followed by the alignment status being displayed as ALN, RDY, or SIM above OSB 13 (Figure 37). The other alignment statuses are MAL, REL and (Blank) (See the list below):

- REL - Indicates that the MMC has confirmed release consent for the selected station.
- RDY - Nav solution quality is Good, all conditions for launch have been met.
- ALN - Nav solution quality is Marginal, but all conditions for launch have been met.
- MAL- Indicates that some failures exist and the weapon cannot be launched.
- SIM - Nav solution quality is Good for simulated loading (for inventory and training).
- (Blank) - Indicates none of the above statuses apply.



The TXA counts down alignment status (i.e. "A10", "A08", "A06"... where "A10" is the worst alignment status), when minimum transfer alignment is received from the weapon.



Figure 122 TXA counts down alignment status

When the navigation solution quality becomes "good", either "RDY" or "SIM" is displayed both adjacent to OSB 6 and above OSB 13. "RDY" is displayed in both windows if the MASTER ARM switch is in ARM. "SIM" is displayed in both windows if MASTER ARM is in SIM. If MASTER ARM is in the OFF position and navigation solution quality is "good", TXA quality continues to be displayed adjacent to OSB 6, while the window above OSB 13 remains blank. The table below shows the TXA values for the different IAMs:

TXA Quality	JDAM	JSOW	WCMD
10	Unsat	Unsat	Unsat
9	Unsat	Unsat	Unsat
8	Unsat	Marginal	Unsat
7	Unsat	Marginal	Unsat
6	Unsat	Marginal	Unsat
5	Unsat	Marginal	Unsat
4	Unsat	Good	Unsat
3	Marginal	Good	Marginal
2	Good	Good	Good
1	Good	Good	Good

Table 10 TXA values for the different IAMs

If MASTER ARM is in the OFF position and navigation solution quality is “marginal”, the TXA quality continues to be displayed adjacent to OSB 6 and the window above OSB 13 remains blank. With MASTER ARM OFF, a “good” status will have the same indications—blank at OSB 13 and TXA countdown at OSB 6. If a failure occurs during MDT or transfer alignment, “MAL” is displayed in both windows for the selected station. The display of “MAL” will be independent of the position of the MASTER ARM switch.

Note: Releasing an IAM when warm-up status is Unsat or Marginal is not recommended and will probably cause the weapon to miss its designated target.

3.4.7 Weapon Delivery Submodes

All three IAMs include A-G mechanizations for Preplanned (PRE) and VIS weapon delivery submodes. Additionally, the JSOW has a Mission Planned Preplanned (MPPRE) submode. See Figure below for PRE, VIS, and MPPRE typical weapon delivery flight path profiles (MPPRE is not implemented at this time and is equivalent to PRE).

3.4.7.1 VIS

VIS is used for visually acquired targets. In VIS mode, the weapon attack azimuth is the aircraft LOS to the target and the weapon flies directly to the target. The appropriate impact spacing is applied if a multiple release impact option (side-by-side or tandem) is selected.

3.4.7.2 PRE

PRE is used to attack any steerpoint sensor track such as TGP, FCR Fixed Target Track (FTT), or datalink point. PRE target data may include latitude, longitude, elevation, target offset, and attack axis. The weapon flies to the target along a defined Attack Azimuth (JSOW, WCMD)/Impact Azimuth (JDAM), or directly to the target if no attack azimuth has been defined. The appropriate impact spacing is applied if a multiple release impact option (side-by-side or tandem) is selected. For JSOW PRE, JSOW In-Zone (JIZ) indicates that when released the weapon will fly to the target along the attack azimuth, if an attack azimuth is specified (i.e., non-zero), or will fly directly to the target if no attack azimuth is specified.

3.4.7.3 Mission Planned Preplanned (JSOW) (N/I)

MPPRE is unique to the JSOW weapon and provides for a single weapon release (no ripple available) against preplanned targets normally having associated waypoints. In MPPRE, the JSOW will fly through up to eight waypoints and then to the target on a final attack azimuth if defined. The weapon will revert to direct targeting along the attack azimuth if it cannot reach the target by flying through all the defined waypoints.

The figure below summarizes IAM delivery submodes and describing the associated weapon flight path profiles:

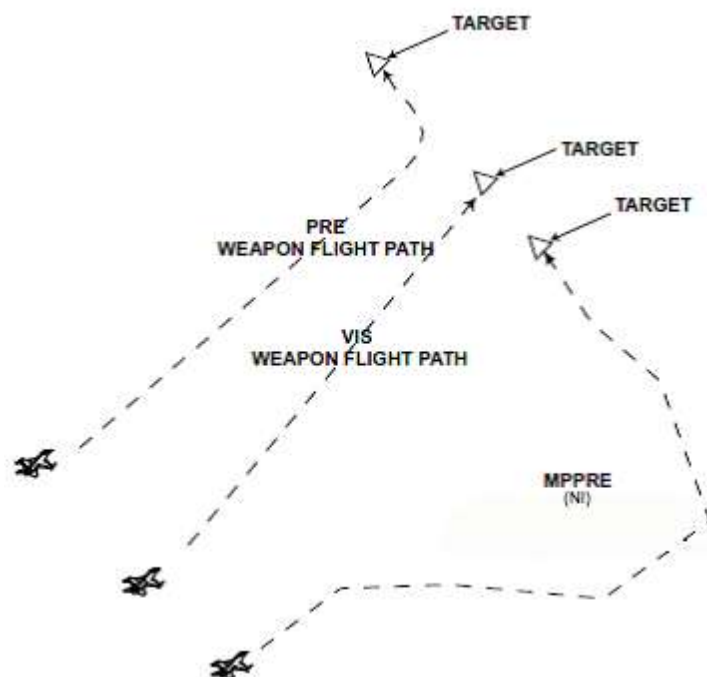

Figure 123 IAM delivery submodes weapon flight path profiles

Please note: For now, until an appropriate UI DTC feature is implemented to support MPPRE waypoints definitions and management, MPPRE mode will not have waypoints support but only direct targeting or via attack azimuth. MPPRE mode can be selected only when the current STPT is a target STPT. When in MPPRE mode, FCR and TGP slewing will not affect target position and it'll stay permanently on the MPPRE location.

Weapon Parameters Special Note: While for each IAM all the MFD labels and options are implemented only some of those parameters have a real effect in the simulation environment. For now, the following parameters have no real effect on gameplay although you can set/change their values: JDAM Impact Angle, JDAM Impact Velocity, WCMD Attack Azimuth (while not used for weapon flight it is used for ripple impact option to calculate impact spacing offset), WCMD Target Wind and WCMD Wind Source.

3.4.8 Impact Option (JSOW, WCMD)

Impact option provides the capability to select whether one or two weapons may be released against a target. The option to select whether two weapons may be released against one target is only available for JSOW (PRE and VIS delivery submodes only) and WCMD (JDAM can only be launched singly). The impact option is selectable for change via OSB 19 on the JSOW and WCMD weapon base pages. The impact option is not displayed on the SMS control pages. Depressing OSB 19 on the base page rotaries though the allowable impact options that is summarized below. The following are JSOW and WCMD Impact Geometries:

- Single (One Triangle). One weapon is to be dropped on the target.
- Tandem (Two Triangles Stacked Vertically). Two weapons are to be dropped on the target with impact points along the attack axis. The first weapon in the ripple sequence (currently selected weapon) will be released against the short impact point and the second weapon will be released against the long impact point.
- Side-By-Side - (Two Triangles Abreast) Two weapons are to be dropped on the target with impacts points perpendicular to the attack axis. The station 3 weapon will be released against the left impact point and the station 7 weapon will be released against the right impact point.

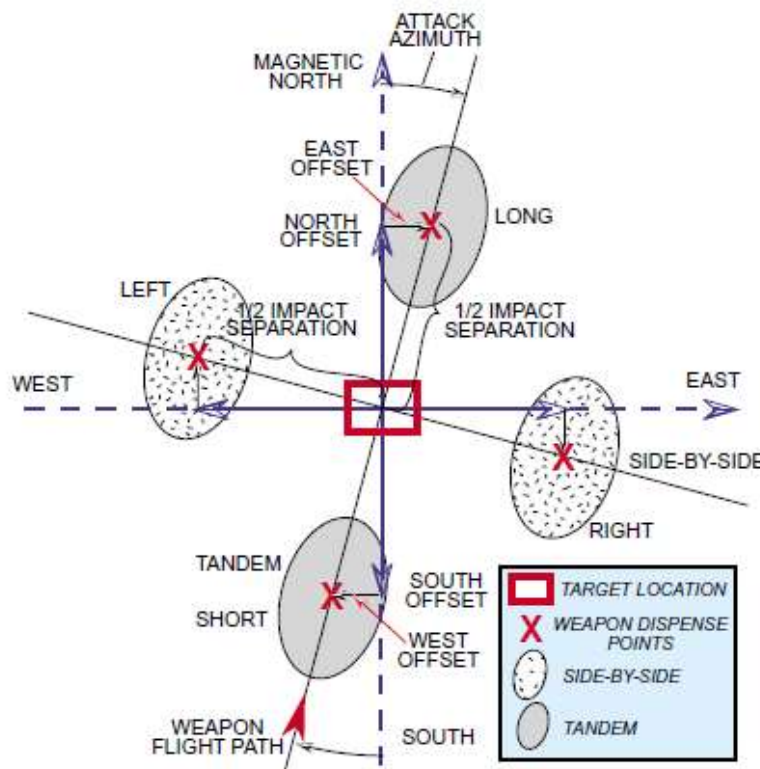

Figure 124 JSOW and WCMD impact geometries

Note: When the tandem or side-by-side impact option is selected, the avionic system will automatically select the ripple release option. Each weapon receives target latitude, longitude and elevation. In addition, weapon-unique offsets values are sent to each weapon based on the selected impact spacing option, attack azimuth and impact spacing distance. When any of the following conditions occur, the avionic system will automatically default the release option to single and ripple will not be available:

- 1) Only one IAM station in a pair is loaded in inventory (even quantity zero).
- 2) MPPRE is the currently selected delivery option. (JSOW only).
- 3) There is a mix of IAMs actually loaded on the aircraft, or
- 4) Different weapon IDs have been inadvertently loaded on stations 3 and 7
- 5) A station is loaded with a failed JSOW or WCMD.

3.4.9 Impact Spacing (JSOW, WCMD)

The impact spacing value determines the distance between the centres of the two submunition dispense patterns during a ripple release (tandem or side-by-side). The pilot defined target location is the centre of the combined submunitions patterns. The impact spacing can be changed using OSB 18 on the JSOW and WCMD Weapon base pages. Impact spacing is not displayed on the JSOW and WCMD Weapon control pages. Depressing OSB 18 on the base page will access the data entry MFD page for modification of the impact spacing value. If a value of zero is entered, the weapons will have coincident impact points. Although an impact spacing of 9999 feet may be entered, the DLZ is only calculated to the centre point. This could lead to one of the weapons being released outside acceptable parameters. The impact spacing value is not displayed on the JSOW and WCMD Weapon base pages when the Single impact option is selected.

3.4.10 Target Profile Data Sets (JDAM)

Four different profiles (one each for up to four individual targets) can be defined based on the individual target characteristics. Target profile data sets may be used with all JDAM variants. The four targeting and weapon parameters below constitute a target profile data set in BMS:

- 1) Impact Azimuth (see Attack/Impact Azimuth in this Section).
- 2) Impact Angle (Not currently implemented).
- 3) Impact Velocity (Not currently implemented).
- 4) Arming Delay (see Arming Delay in this Section).

The profile numbers have a logical relation to the target desired. As the pilot rotates through the different profiles (PROF 1 through PROF 4) the parameters change reflecting the different target characteristics. As mentioned in the preceding descriptions, the pilot may select each of the targeting/weapon parameters for change on the JDAM weapon control page. When a parameter is changed on the control page, the data set associated with the PROF number currently being displayed at OSB 20 on the JDAM weapon base and weapon control pages is also changed.

3.4.10.1 **Attack Azimuth (JSOW, WCMD)/Impact Azimuth (JDAM)**

Attack/impact azimuth provides the capability to allow the weapon to attack the target from a specific direction always referenced to North. Attack azimuth is the terminology used for JSOW and WCMD, while impact azimuth is the terminology used for JDAM. The attack azimuth value is selectable for change for JSOW and WCMD at OSB 20 on the JSOW and WCMD control pages. Azimuth is entered through the mission planning system or control pages. The JDAM impact azimuth value is selectable for change at OSB 7 on the JDAM control page. Depression of the ATK AZ or IMP AZ OSBs will access the data entry MFD page for attack/impact azimuth. Any value between 0 and 360° may be entered; however, an entry of 0 will be considered invalid to the weapon and will cause the weapon to fly from the release point direct to the target. For WCMD in ripple release mode, the avionic system uses the attack azimuth to calculate target offsets for each weapon to achieve at the target. At release, the bombs will fly from the aircraft direct to the target and the offset sent to the weapon is corrected/adjusted for the Attack Azimuth input.

Note: The avionic system will accept manually entered attack/impact azimuth greater than 360°. Attack azimuth inputs greater than 360° will be reduced by 360° or multiples of 360° and sent to the weapon. For example, an entry of 370° results in 10° and an entry of 740° results in 20° being sent to the weapon. In the VIS delivery submode, the avionic system will set the impact/attack azimuth to the aircraft LOS to the target.

3.4.10.2 **Arming Delay (JDAM, WCMD)**

The arming delay is a weapon function that provides a safe separation arm time for JDAM and WCMD weapons. The arming delay is displayed on the SMS base and control pages. The arming may be changed at OSB 19 on the WCMD and JDAM control pages. Depressing OSB 19 on the appropriate control page accesses the data entry MFD page for the arming delay value. Any value between 0 and 99.99 seconds may be entered.

3.4.10.3 **Burst Altitude (WCMD)**

Burst altitude is the desired function altitude for WCMD and is displayed on the WCMD SMS base and control pages. Burst altitude may be modified at OSB 18 on the WCMD SMS control page. Depressing OSB 18 accesses the data entry MFD page for modification of the burst altitude value. Burst altitudes are in feet Above Ground Level (AGL).

3.4.10.4 **EGEA (End Game Entry Altitude) And ROB (Range on Bearing) For JSOW variants**

The EGEA and ROB parameters for JSOW in the PRE delivery mode are displayed on the SMS JSOW base and CNTL pages. The pilot may modify these values using the SMS JSOW CNTL page. EGEA defines a minimum altitude relative to the target altitude that the weapon will fly at endgame entry range. This range from the target is where the JSOW will begin its terminal maneuvers. ROB is defined as the minimum range from the target where the weapon's velocity vector will be in line with the planned attack azimuth. ROB has a range of 4 to 9 NM for the A variant and 2.5 to 9 NM for the B (and C) variant. Changing the EGEA will affect the elevation of the JSOW flight path weapon trajectory in order to avoid weapon impact with the terrain prior to arriving at the target. Changing the ROB will change the JSOW flight intercept point with the attack azimuth. JSOW approaches the target along a specified bearing and intercepts that bearing at or beyond the specified ROB from the target. The altitude of the weapon at the ROB intercept point is not specified.

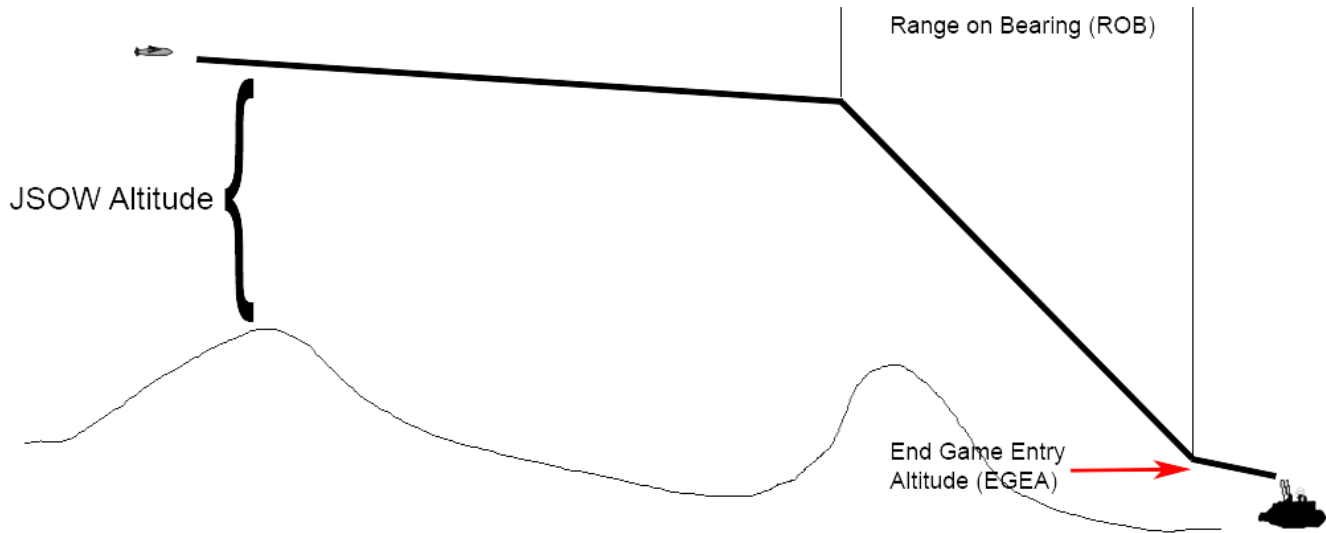

Figure 125 JSOW EGEA and ROB

AGM-154C does not have EGEA, and thus, EGEA and its value (all modes) are not displayed on the base page. For AGM-154A, the default value for EGEA is 700 feet and the default value for ROB is 4.0 nm. The AGM-154C does not have EGEA capability; the default value for ROB is 2.5 nm. EGEA value is limited between 500 to 2500 feet and ROB is limited between 4.0 and 9.0NM for AGM-154A and between 2.5 and 9.0NM for AGM-154C.

3.4.10.5 Laser Code for Laser JDAM

The laser code for Laser JDAM can be changed while airborne via OSB 7 in control page 1. Pressing OSB 7 will switch the MFD to input display mode where the new laser code can be entered. Valid values for the laser code are between 1511 and 1788. The laser code is only changed for the selected weapon and doesn't apply to any other Laser JDAMs loaded on the jet; so unless a different laser code (than the default) is necessary, it will still be more efficient to load all the bombs with the required laser code in the LOADOUT screen before the flight.

3.4.10.6 Laser Receiver Mode for Laser JDAM

The laser receiver mode can be found in control page 2 and the valid values are either OFF or AFTER. The receiver mode defines whether the bomb will operate the laser receiver after release. The default value is OFF which means that the laser receiver will not operate after release and the bomb will act as a JDAM only. Switching to AFTER mode before a drop will instruct the bomb to operate its laser receiver; if a laser spot with matching laser code is detected, the bomb will follow the laser spot coordinates. For static targets Laser JDAM doesn't require continuous lasing like LGBs because once a laser spot is detected, the bomb will extract the coordinates from the laser spot and use those coordinates to maneuver to the updated target position.

When impact azimuth is set for Laser JDAMs and the bomb is released within LAR2 range to follow the selected azimuth, the bomb will follow the laser spot only at the end game maneuver towards the target.

If impact azimuth is selected and the laser spot is too far away from the target position that the bomb was released at, the end game maneuver may be too great for the bomb to reach the target.

3.4.11 HUD Symbology for IAM Weapons Delivery

The IAM weapons and the avionic system provide the pilot with information to aid in the weapon delivery. Much of this information is portrayed using the HUD symbology. The symbology includes the HUD Dynamic Launch Zone (DLZ), and other miscellaneous HUD steering and release cues.

3.4.11.1 *IAM HUD DLZ*

The HUD DLZ is displayed when an IAM weapon is selected, valid LAR (Launch Acceptable Region) data for the selected weapon has been downloaded to the MMC, the appropriate delivery submode (MPPRE, PRE, VIS post designate) is selected, the weapon status is REL, RDY, ALN, or SIM, and INS and CADC data are valid.

3.4.11.2 *IAM HUD DLZ composition*

1. Upper and lower range scale tics. No range scale value is displayed above the upper range scale tic. For JDAM and WCMD, the DLZ is displayed "normalized" so that the RMAX1 range tic is always displayed at 70% of the selected IAM weapon's kinematic range. The DLZ is normalized to 70% for JSOW PRE and VIS modes.
2. Target range caret (>). The target range caret appears to the left of the kinematic and optimum release zones/staples.
3. RMAX1 / RMIN1 (I). The maximum and minimum weapon kinematic ranges form an outer staple (kinematic release zone) that opens to the right. Releasing the weapon with the target range caret between RMAX1 and RMIN1 (within the kinematic release zone) ensures that the weapon can get to the target. However, the weapon may not arrive with enough energy to meet all end-game parameters such as impact angle, impact azimuth, and minimum impact velocity. With the exception of the JSOW, IAM weapon releases are inhibited until the target range cue is between RMAX1 / RMIN1. The kinematic release zone is based on current aircraft flight conditions.
4. RMAX2 / RMIN2 (J). The maximum and minimum optimum release ranges form an inner staple (optimum release zone) that opens to the left. Releasing the weapon with the target range caret between RMAX2 to RMIN2 ensures that the weapon can get to the target with enough energy to meet all end-game parameters. The optimum release zone is based on current aircraft flight conditions. For JSOW PRE and VIS and for CBU-103 and CBU-104, there is no RMAX2/RMIN2 since there are no end-game parameters to satisfy.
5. JIZ Indication. JSOW In-Zone (JIZ) is sent by the weapon and displayed in HUD adjacent to the range caret, to indicate JSOW in-zone conditions based on selected weapon delivery submode. The DLZ is calculated by the MMC and may not correlate with weapon JIZ indications. The weapon release button is always hot whenever JIZ is displayed. If a non-zero quantity of JSOWs are loaded in inventory, "JIZ" is displayed for JSOW when the weapon is reporting that it is "in-range."
6. Required turn angle below the DLZ. This window is the direction and magnitude of turn required to position the aircraft in the LAR (for JDAM only and displayed when above 60° offset from target bearing). The depiction consists of one alpha character indicating turn direction left (L) or right (R) followed by two numeric characters indication magnitude in degrees 00-99. For example L05 indicates a left turn of 5°.

Note: IAM LAR and DLZ depictions are based on a limited quantity of weapon flight data (truth data) and are the most accurate for medium altitude level releases. LARs and DLZs for low altitude and/or diving releases are typically derived by extrapolation of level release truth data and tend to be less accurate.

The DLZ for JDAM and WCMD will be blanked when aircraft speeds are less than 0.5 Mach or greater than 1.5 Mach. In addition, the DLZ will be blanked under any of the following conditions:

- For JDAM, when target bearing exceeds +/- 60°, pitch angle exceeds +/- 60°, impact angle lower than 20° or impact velocity greater than 1200 ft/sec.
- For WCMD, when aircraft altitude is below the fuse function altitude of the weapon or target bearing exceeds +/- 45.

The JIZ depiction is blanked for all JSOW delivery submodes when aircraft speeds are less than 0.6 Mach or greater than 0.95 Mach, aircraft climb/dive angles exceed +/-30°, when target bearing exceeds +/- 60°, or aircraft altitude exceeds 40,000 feet.

3.4.11.3 HUD Steering and Release Cues

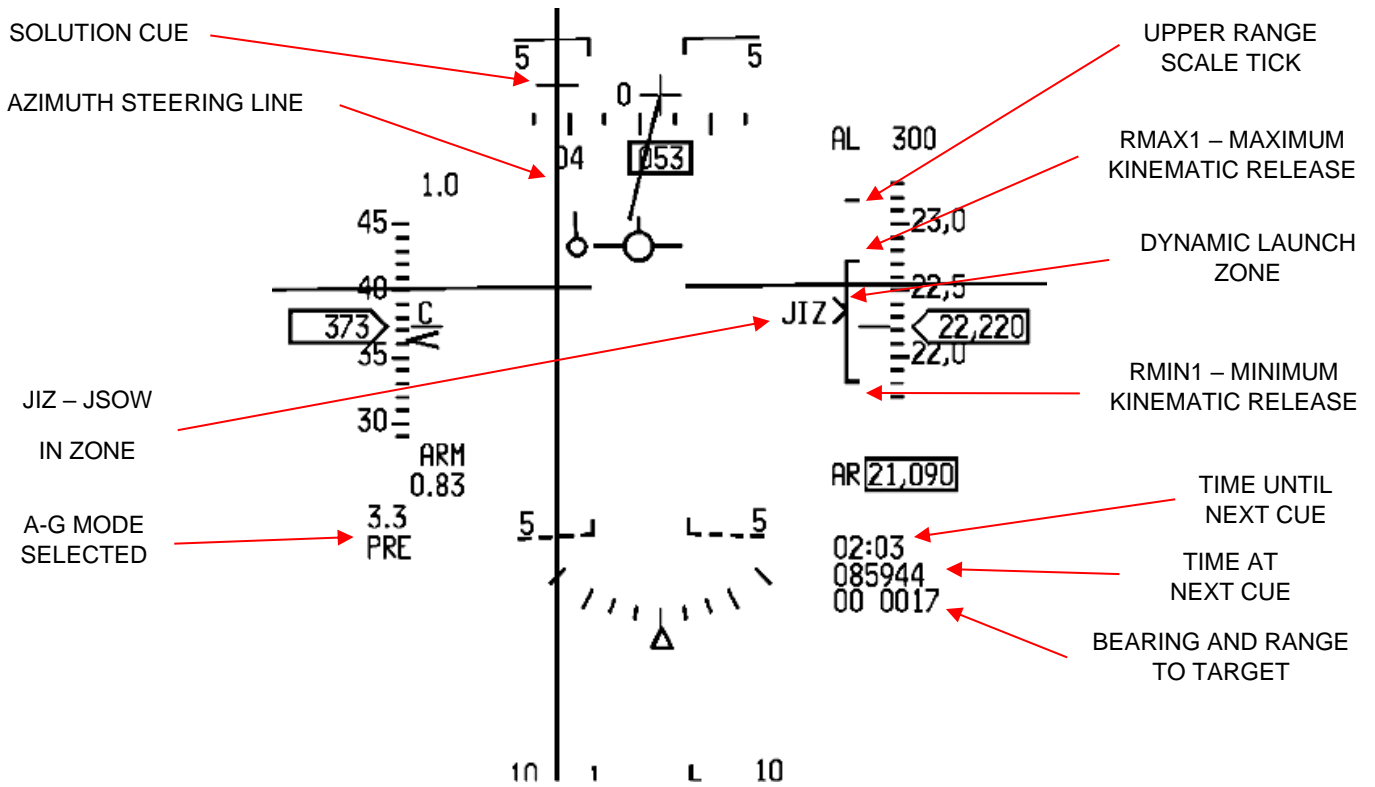

Figure 126 JDAM/WCMD/JSOW PRE/VIS-Post-Designate and JSOW MPPRE HUD steering and release cues

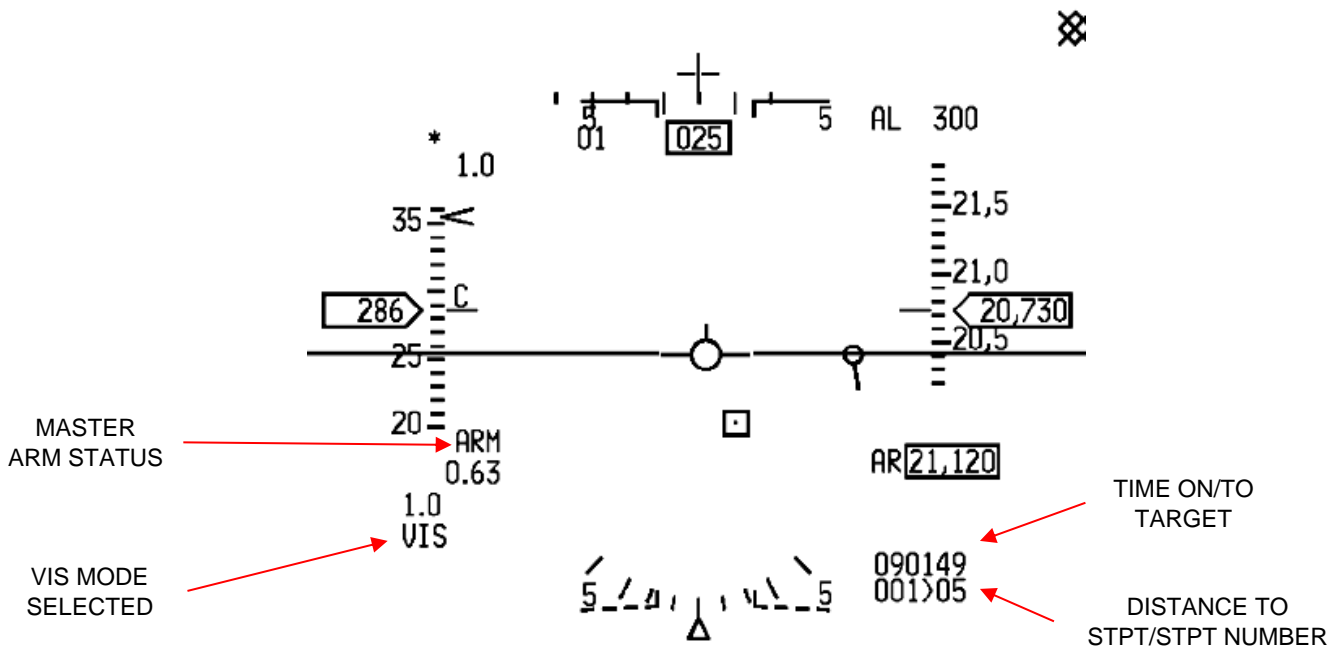

Figure 127 Predefined steerpoints location

Time until next cue. This is displayed until the countdown to the next cue (time to loft, time to RMAX1) reaches zero (then time since RMAX1 until RMAX2 and weapon release actually counts upwards for a few seconds) or a launch has been completed, whereupon it displays predicted time to impact for the last weapon released.

Time at next cue. This indicates the system time at the next cue (as above) based on current flight conditions.

Range and bearing to target. For JDAM, WCMD, or JSOW (PRE and VIS) the bearing and range to the target is displayed in the HUD.

Azimuth steering line (ASL). The ASL provides optimum steering to the weapon release zone. In JDAM, JSOW, and WCMD PRE or VIS, and JSOW MPPRE with no waypoints defined, the ASL provides steering to the target. The ASL is blanked from the HUD, when the weapon status is MAL or blank. The ASL is displayed when weapon status is ALN, RDY, or SIM.

A-G solution cue. The solution cue is displayed when the aircraft approaches the optimal release zone (RMAX1 to RMIN1) or when a change in climb angle can bring the aircraft within the optimal release zone and is centred in azimuth on the azimuth steering line. The cue begins moving down toward the flight-path marker at max loft release range. The cue is coincident with the flight-path marker when the aircraft is within the optimal release zone indicating that the current conditions support a release. When a dive is required to achieve release conditions, the cue will move below the flight-path marker. The solution cue is displayed when weapon status is ALN, RDY, or SIM. Since JSOWs are not meant to be lofted, the solution cue will only be displayed when the aircraft is within the aircraft computed optimal release zone. Thus, the cue should be ignored for JSOW since release determination is based on the weapon computed in-range/in-zone and not the aircraft computed DLZ. The solution cue is blanked when the weapon status is MAL or blank. The pickle button is hot prior to the solution cue being coincident with the FPM.

Target designator (TD) box. The TD box represents line-of-sight to the target. The TD box is blanked when the weapon status is MAL or blank. The TD box is displayed when weapon status is ALN, RDY, or SIM.

Arming Status. The position of the master arm switch (ARM or SIM) is displayed below the HUD airspeed scale.

Delivery Mode Indication. The currently selected delivery IAM submode (MPPRE, PRE, or VIS) is displayed at the lower left portion of the HUD.

JDAM/WCMD LAR2 scale: When Impact or attack azimuth is selected for JDAMs or WCMDs, a LAR2 will appear on the HUD DLZ. The LAR2 upper tick will mark the minimum release range which will allow the bomb to follow the attack azimuth on the way to the target. Release above that range will force the bomb to give up the attack azimuth and fly directly to the target.

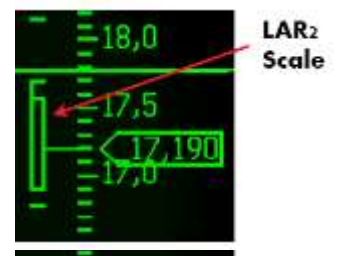

3.4.12 IAM Weapon Release Considerations

1. To successfully launch IAM weapons, the weapon release button must be depressed throughout the entire launch sequence. This can take up to 1.6 seconds for a single release and over three seconds for a ripple release. If the pickle button is not held down throughout the launch sequence, the launch will be permanently aborted and subsequent release attempts for that weapon will not be possible (selective or emergency jettison can still be used to jettison the weapon). For either weapon release sequence, if the pilot releases the weapon release button prior to the actual release of that weapon, the aircraft will set the weapon status at the applicable station to "H" (HUNG status).
2. Cursor Zero: To prevent unwanted cursor slews from being applied to the weapon solution, a cursor zero should be commanded prior to weapon release.
3. Weapon Release Button for JDAM and WCMD: The weapon release button is hot in all applicable delivery submodes whenever the aircraft is within the kinematic release zone (RMAX1 to RMIN1) of the weapon. Weapon release can be initiated in one of two ways: 1) if the aircraft is within RMAX1 to RMIN1, weapon release will be initiated when the pickle button is depressed, 2) if the aircraft is outside of RMAX1 to RMIN1, hold the pickle button depressed and fly the aircraft into the DLZ at which time the release sequence will be initiated. *Note:* When initiating a multiple release sequence close to RMIN, and closing in to the target, the release sequence will continue and the second weapon may miss the target, depending on the conditions.
4. Weapon Release Button for JSOW/SDB: In-range and in-zone are JSOW weapon generated range functions, and the DLZ range data (RMAX1 / RMIN1 are generated from aircraft (core computer) calculations. There are conditions where the weapon-generated functions and DLZ range data will not agree. As a result, DLZ information should be considered to be "rule of thumb" data and the weapon-generated data should be considered the most accurate. The weapon release button will always be hot whenever the weapon reports an in-range condition regardless of weapon delivery submode or DLZ range depictions. However, cockpit indications do not always advise when a JSOW in-range condition has been satisfied. In PRE, VIS, or MPPRE, JIZ is displayed on the HUD and the weapon release button becomes hot when the weapon is indicating in-range regardless of where the DLZ range cue is positioned. For JSOW PRE and MPPRE, JIZ indicates that when released, the weapon will fly direct to the target if no attack azimuth has been defined. Otherwise, the weapon will fly to a target offset point that provides sufficient maneuvering space to turn and hit the target on the specified attack azimuth. The weapon release button becomes hot when the weapon reports an in-range condition. Since there is no cockpit indication that an in-range condition has occurred and that the weapon release button is hot, an inadvertent (in-range) release may be possible.

3.4.13 JSOW, JDAM, SDB, WCMD PRE Weapons Delivery Procedures

1. 1 ICP - Select/verify A-G Master Mode.
2. UFC/DED -
 - a. Select/verify desired PRE target (steerpoint number).
3. SMS weapon base and control page -
 - a. Verify/input correct weapon inventory load.
 - b. Verify power ON for each loaded station.
 - c. Verify PRE submode selected.
 - d. Verify correct weapon stations selected.
 - e. Verify weapon status.
4. Cursor Control - Zero cursor, unless cursor corrections required.
5. MASTER ARM switch - ARM.
6. HUD
 - a. Use HUD steering cues to manoeuvre until range caret is within launch zone.
 - b. Verify JIZ displayed adjacent to range caret (JSOW only).
 - c. Verify range caret within RMAX1 / RMIN1 (JDAM/WCMD).
7. WPN REL button - Depress and hold until the FPM flashes (> 1.6 seconds for single, or 3.2 seconds for ripple).

3.4.14 JSOW, JDAM, WCMD VIS Weapons Delivery Procedures

1. ICP - Select/verify A-G master mode.
2. SMS weapon base and control page -
 - a. Verify correct weapon stations selected.
 - b. Weapon power ON for each loaded station.
 - c. Verify weapon status.
3. MASTER ARM switch - ARM
4. HUD -
 - a. Select/Verify TD Box is displayed coincident with FPM. Verify vertical position and/or velocity errors (FPM not on horizon in level flight).
 - b. Slew or fly TD box over the target and designate. Do not designate the target via the WPN REL button unless no slew refinements are required.
 - c. Verify azimuth steering to the TD box is displayed.
 - d. Use HUD steering cues to manoeuvre into release parameters.
 - e. Verify JIZ displayed adjacent to range caret (JSOW only).
 - f. Verify range caret within RMAX1 / RMIN1 (JDAM and WCMD)
5. WPN REL button - Depress and hold until the FPM flashes (> 1.6 seconds for single, 3.2 seconds for ripple).

3.4.15 Guide on IAM usage

3.4.15.1 *PRE mode*

In order to use IAMs as pre-planned GPS targeting weapons you need to assign the target you want to a steerpoint. Choosing PRE will automatically set the current steerpoint position set as the weapon target position. If release conditions are met, releasing the IAM will send it to hit the target (steerpoint) position. In PRE mode, any slewing of the current used sensor (FCR or TGP) will change the target position and send it to the weapon. Releasing a weapon at this stage will send it to the position where the sensor cursors are pointing.

3.4.15.2 *JDAMs and SDBs single pass – multiple targets procedure*

The F-16 cannot release JDAMs in ripple mode so in order to release multiple JDAMs in one pass on multiple targets you should follow these steps:

1. During planning in the UI map screen, assign a steerpoint for each target in subsequent order— i.e., 5-6-7-8 for 4 targets.
2. When in range of the targets (assuming they are all in the same area, otherwise this will not work) with the first target steerpoint chosen and cursor-zero (no slewing necessary), releasing the first JDAM/SDB will send it towards the first target.
3. Quickly choose next steerpoint.
4. Release a second JDAM/SDB. Repeat step 3 for the remaining bombs.

Following this procedure (which is real for the F-16) will let you use JDAMs or SDBs as a pre-planned GPS guided weapon and drop many in one pass.

Note that since the LAR is flexible and assuming flight conditions allow, targeting four different targets in one pass by slewing the TGP between drops is possible.

3.4.15.3 *VIS mode*

Vis mode is similar to the Mavericks visual mode and enables targets to be attached in a fast, visual way. It has two stages—pre- and post-designate. When in pre-designate state the TD box will be attached to the FPM and may be slewed or flown to the target position. A TMS-UP command will stabilize the TD box and cursor slews will fine tune its position. When post-designated, no further action is necessary in order to release a weapon on the target position. Once the post-designate stage is reached, the TD box position has been sent to the weapon and once released the munition will guide to that target position.

3.4.15.4 Notes and unique simulation information

- 1) WCMDs are modelled regardless of the wind in the sim and they will hit targets like the JDAMs do.
- 2) 1.6 seconds pickle delay is implemented for all IAMs and when launch parameters allow (pickle is hot) and pickle button is pressed, you *must* hold it until weapon release, otherwise you'll get a HUNG weapon. If you suffer a HUNG weapon you'll be able to switch stations using the missile step command. JDAMs/WCMDs can switch stations just like missiles.
- 3) AI will use IAM bombs before they use other bombs (LGBs or dumb). They will release multiple IAM bombs in one pass on different targets. They do that automatically if they are on independent flights and they will do that as wingmen if you direct them to "attack targets." AI will be limited to single IAM bomb drops and to the pickle delay.
- 4) When firing long range missiles, the player can turn back and the targets should stay deaggregated until the missiles explode. Note this feature might saturate multi-player bandwidth availability. A maximum of four long range missiles (per player) are supported to force target deaggregation in any direction in the theatre.
- 5) While not directly related to IAMs, FCR/TGP track points will force deaggregation of the targets in the area of the cursors.
- 6) JSOW MPPRE mode will be allowed only when the current steerpoint is a target.
- 7) The TGP will be loaded automatically when IAMs are loaded, just as it does for LGBs.
- 8) IAMs do not require any kind of "locking" of targets. If you are having trouble releasing and hitting targets with IAMs, follow the procedures explained in the "How To" section.
- 9) While attack azimuth is used for JSOW and affects the flight path, it may not be completely accurate. There may be some undesired differences between the required azimuth and the practical one. Hopefully this will improve in the future.

3.4.15.5 Special JDAM options

Note: The following section applies primarily to IAF F-16 C/D and IAF F-16I versions.

To support special JDAM options for all aircraft types, a variable is available in the FM data file. The variable is named *avionicsJDAMAvionicsType* *** **CAUTION! Changing aircraft data may cause multiplayer problems!** ***

The valid values are 0-3 and can also be found in the avionics configurator under JDAM option.

The valid values for this variable represent the following:

Value 0 – Normal JDAM behaviour as described in section 3.4.1 (default value if not specified in FM).

Value 1 – Allow ripple for JDAMs. Ripple value can be set in the SMS page and the JDAMs will be rippled by the specified amount with every pickle press. Other than that, the avionics and functionality will be same as described in section 3.4.1.

Values 2 & 3 – This option represents a special JDAM pre-planned targets setting that can be done via a dedicated JDAM’s page on the DED. With this option enabled, the ripple option will appear on the SMS page but it will not necessarily represent the actual ripple number. The value on the SMS page will define a global ripple value, while the actual ripple for every pre-planned target will be defined separately on the DED profile along with other parameters that in the default option (Value 0) being defined in the SMS page.

The JDAMs DED page is entered by pressing 0 in the DED MISC page (the option itself will appear on the MISC page only for aircraft that have option 2/3 set for JDAM avionics type).

3.4.15.6 DED page



Figure 128 JDAM DED page

The JDAM’s DED page contains a header row and 4 target rows.

The header row contains the following information:

- Weapon name – BC for JDAMs
- Targets step mode – Options are Automatic (AUT) and Manual (MAN). Auto is the default. In Auto mode the system will step to the next target row at pickle release.
- Current targets page—Subpage that is currently shown, counting from 00 up to as many subpages as necessary according to the number of bombs loaded (4 for a subpage). Subpages can be toggled by placing the asterisks on the number and pressing M-SEL on the ICP.

The data in every row contains the following information which is assigned for the specified target (listed from left to right):

- Impact angle
- Impact azimuth
- Impact velocity
- Ripple count
- Target STPT number
- "SP" (STPT)

Note: When exiting the JDAMs DED page (CNI-Reset) the first target will be automatically selected by the system, meaning that the next release will be on the first target in the list.

3.4.15.7 SMS page

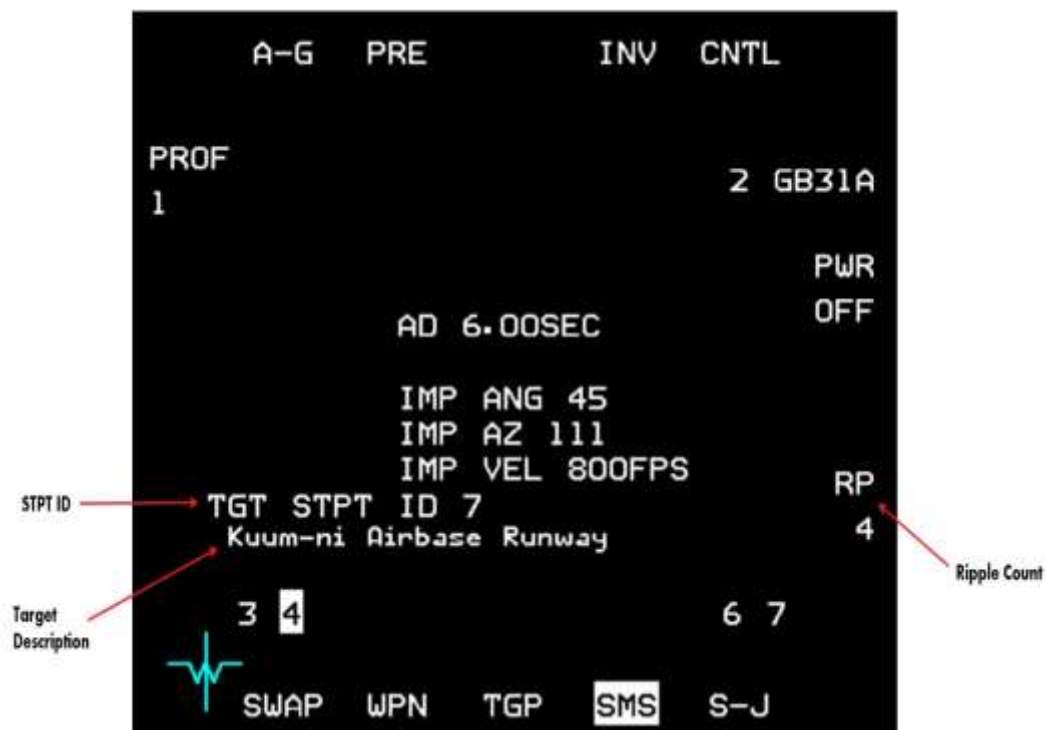

Figure 129 JDAM SMS page

The SMS page contains the same data as the default type JDAM (Value 0) with the following additional information:

- Ripple count – Global ripple count, meaning that even if the ripple count that was specified in the DED for the current target is greater than this value, or for mode 3 the overall ripple on the targets is greater than this value, the ripple sequence will stop after the number of bombs of this value have been released.
- Target STPT ID – The current target STPT.
- Target Description – The name of the current target (the name that appears in the UI recon page).

3.4.15.8 *Release Considerations*

Multiple targets support with a single pickle press

The difference between options 2 and 3 is that in option 2 there is no multi-targeting support. This means that every pickle press will release bombs on the current target STPT only. If Auto step is specified then the next target row will be selected automatically at release of the pickle. In option 3, multi-targeting is supported and so target step may happen in a single pickle press, for each target at the specified ripple count that was assigned to it. For example, in the profile that is described by Figure 128 Figure 128above (assuming there are 6 JDAM bombs loaded of the same type and the SMS ripple count is set to at least 6) and the target STPTs 7, 8, 9 and 10 are close to each other (so all targets are in-range when pickle is depressed), the FCC will release 2 bombs on STPT target 7, 2 bombs on STPT target 8, and 1 bomb for STPT targets 9 and 10.

Note: For option 3, in the case that multiple targets are supposed to be targeted, the TD box and other target specific data will correspond to the average position between the targets with the current pickle press. The average information will be shown regardless of if the targets are in-range. It is the pilot's responsibility to make sure that all targets are in-range at pickle depress, otherwise the sequence will stop when a target is out of range.

JDAM avionics option 2 is assigned by default in the BMS DB to IAF F-16 C/D versions.

JDAM avionics option 3 is assigned by default in the BMS DB to IAF F-16I version.

3.4.16 SPICE Bomb



Figure 130 Spice Bomb

The SPICE (Smart, Precise Impact, Cost Effective) is an advanced EO/GPS guidance kit that was developed by the Israeli company Rafael Advanced Defense Systems. The SPICE can be fed (via a special memory card) preflight with the coordinates of ~100 targets which then can be selected in flight and targeted. It does not have the capability of other IAMs to attack targets of opportunity. The SPICE has a relatively long range thanks to twelve advanced control surfaces. SPICE -1000 variants also have deployable wings similar to JSOW and SDB that help to extend the range even further.

3.4.16.1 Targeting Information

In order to simulate the pre-planned targets feed for the SPICE bombs, a new set of 100 special "weapon target" STPTs information was added to the UI and to the missions/callsign.ini files. In the UI, WPN TGTs can be assigned for the SPICE bomb in the same way as precision TRG STPTs for other weapons.



Figure 131 Weapon target selection

Once weapon targets are selected for the mission (up to 100), each set of targets can be fed to any SPICE bomb that is loaded on the aircraft.

Aircraft in the DB that can use SPICE have a flag in the flight model data file called "CanUseSpice" (can also be found in the avionics configurator). If set to 1, it will allow the special avionics dedicated for the SPICE.

Note: The SPICE in BMS is considered an IAM missile but operates differently.

3.4.16.2 DED page

The SPICE bombs are loaded with targeting data via a dedicated SPICE DED page which is entered by pressing ICP-ENTER in the DED MISC page. This option on the MISC page is available only for ACs that can use SPICE, as mentioned above.

Weapon Name For Spice	Impact Azimuth	Guidance type	Weapon Target ID	Auto/MAN N/I	Current Targets Subpage	Bomb ID On Station	Station Number
BP	065*	IMAGEFRNT	1*	A	1	A	4
	20	231	2	A	1	A	6
	20	0	6	A	1	A	3
	20	111	9	A	1	A	7

Figure 132 SPICE DED page

The SPICE DED page contains a header row and 4 target rows.

The header row contains the following information:

- Weapon name – BP for SPICE
- Guidance type (specific for bomb)
- Auto mode (specific for bomb) – N/I
- Targets Subpage – There are four target rows in a subpage, one row for each bomb that is loaded. If other subpages exist (dependent on the number of bombs loaded) then they can be toggled by having the asterisks on the top row, sequenced to the subpage number and then press M-SEL 0.

For every Weapon/Target row, the following information appears:

- Guidance type – Appears on the top row but belongs to each weapon separately. The type can be toggled between: Image front (default), Image top and GPS. The GPS option requires the weapon to be GPS aligned like any other IAM, otherwise the weapon will use its picture processing technology to find the target.
Use ICP-SEQ to put the asterisks of the current weapon on the guidance type field and press M-SEL 0.
- Auto mode – appears on the top row for each weapon – N/I
- Impact angle – can be changed but has no real impact.
- Impact Azimuth
- Weapon target ID – this number will reflect the target that is assigned to this weapon from the Weapon targets list (simulating the memory card of the real weapon).
- "A 1" – Appears on every weapon's row.
- Bomb ID on station – Tell this weapon's position in the station—A for the 1st bomb, B for 2nd and C for 3rd.
- Station ID – The station that this weapon is loaded on.

Note: Every weapon row in the DED page represents a specific SPICE bomb that is loaded on the aircraft and the settings of that row apply specifically to that bomb.

3.4.16.3 SMS page

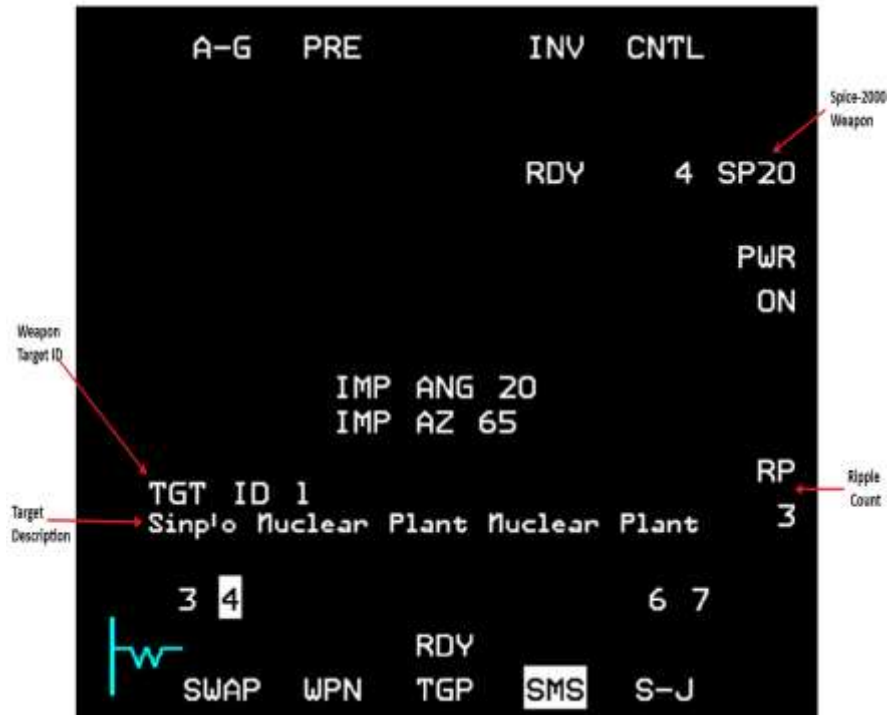
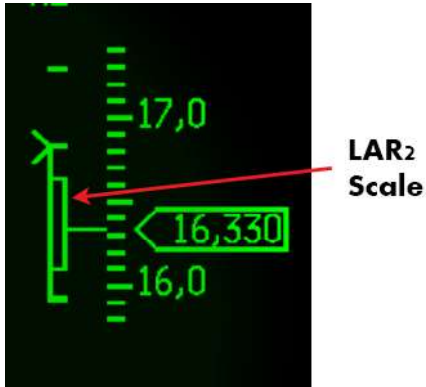

Figure 133 SPICE SMS page

The SPICE SMS page contains same data as JSOWs with the following additional information:

- Ripple count – the number of bombs released when pickle is depressed
- Weapon target ID – the weapon target that is selected for the current weapon
- Target Description – the name of the current target (the name that appears in the UI recon page)

SPICE bombs release sequence is not dependent on the row that is currently selected in the SPICE DED page but only on the station that is currently selected. HUD cues of the SPICE are identical to the JSOWs cues. In the case of a ripple release the TD-Box and all other target-based information will correspond to the average position between the selected targets.



LAR2 Scale: When an attack azimuth is selected for the current SPICE weapon, a LAR2 scale will appear on the LAR scale. The LAR2 scale will indicate if the range is sufficient for the weapon to fly to the target through the selected attack azimuth. If the weapon is released when inside the LAR scale but outside of the LAR2 scale, the weapon will fly directly to the target and not through the attack azimuth.

Note: If the average target is in range then the weapon will be released even if the actual target of that weapon is out of range.

Figure 134 SPICE LAR2 Scale

Four variants of the SPICE exist in the BMS DB:

1. SPICE 2000 – 2000lb HE bomb
2. SPICE 2000P – 2000lb Penetration bomb
3. SPICE 1000 – 1000lb HE bomb
4. SPICE 1000P – 1000lb penetration bomb

3.4.16.4 SPICE Release Procedure

1. Before the mission, set up the necessary weapon targets in the UI.
2. Power up the weapons from the SMS page and note good calibration after warm-up time (RDY label).
3. Open the SPICE DED page.
4. Set for every SPICE bomb the necessary parameters – Target ID, Impact Azimuth, Impact Angle.
5. Set the wanted ripple count if ripple is preferred.
6. Verify In-Range on HUD DLZ. If impact azimuth is selected, verify also that the range marker is below the top mark of the LAR 2.
7. Verify that all targets are In-Range in case of ripple release.
8. Pickle – verify not in dive angle in order to avoid undershoots.

3.4.17 LGMs – Laser Guided Missiles

Laser Guided Missiles are missiles that guides on laser energy. An example is the AGM-123 Skipper II.

AGM-123 Skipper II is a short-range laser-guided missile developed by the United States Navy. The Skipper was intended as an anti-ship weapon, capable of disabling the largest vessels with a 1,000-lb (450-kg) impact-fused warhead.

It is composed of a Mark 83 bomb fitted with a Paveway II guidance kit and two Mk 78 solid propellant rockets that fire upon launch. The rockets allow the munition to be dropped further away from the target than free-fall bombs, which helps protect the delivery aircraft from surface-to-air-missiles and anti-aircraft artillery near the target.



Figure 135 AGM-123 Skipper II

3.4.17.1 SMS page

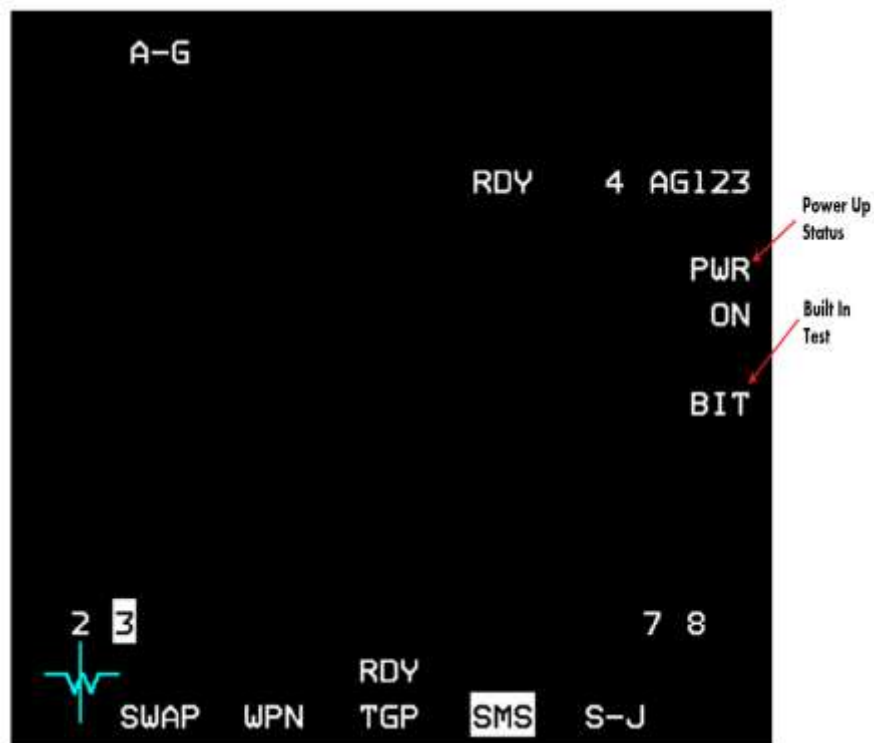

Figure 136 LGM SMS page

LGM SMS page contains:

- Power up status – ON/OFF states
- BIT

Power: Once power is applied via OSB 7, all LGMs on all stations will be powered up. Weapons will be ready after a short BIT of a few seconds.

BIT: Built-In test on demand can be applied by pressing OSB 8. The BIT mnemonic will highlight for a few seconds during the BIT. During BIT the missiles cannot be launched.

3.4.17.2 LGM Release Procedure

1. Power up the missiles via the SMS page.
2. Fly towards the target until the weapon is in range (DLZ)
3. Make sure there is a stable laser spot on the target (using self or Buddy lasing)
4. Pickle to release the missile
5. In case of self lasing keep the TGP pointed at the target and keep firing the laser until the missile hits.

3.5 LASER GUIDED BOMBS (LGBs)

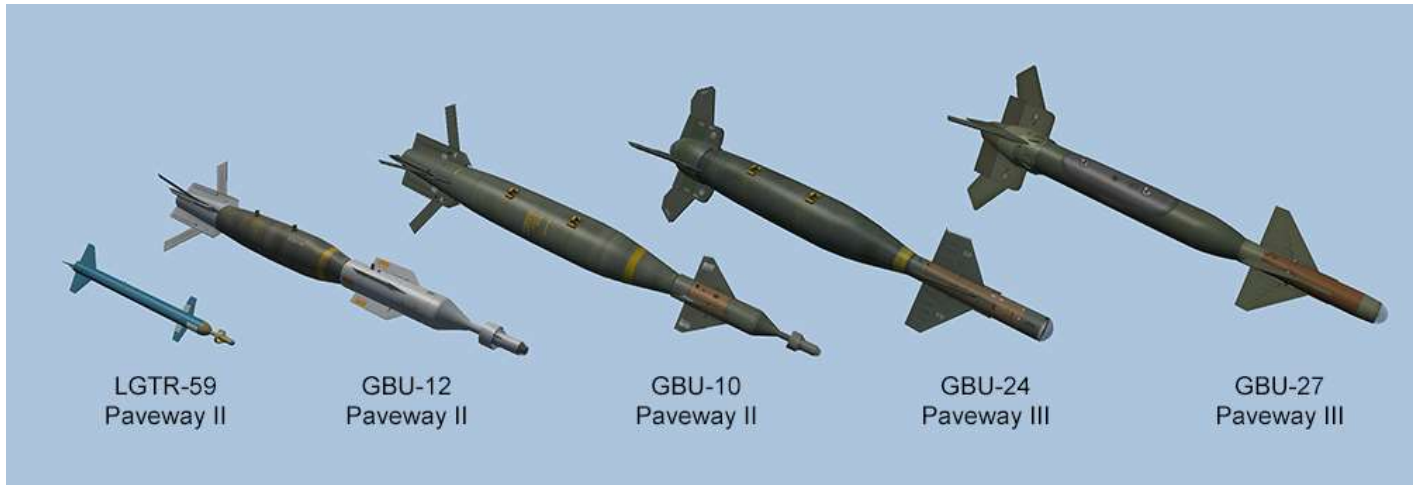

A Laser Guided Bomb (LGB) is a manoeuvrable free-fall weapon, attached with a laser guidance kit, which guides to a spot of laser energy reflected off the target. The LGB is delivered like a normal GP bomb, and the laser guidance kit will correct the trajectory errors in order to hit the laser illuminated target.

Since the weapon is tracking a light signature and not the object itself, the target must be illuminated from a separate source.

In BMS we have two generations of LGB's: Paveway II (LGTR-59, GBU-10, GBU-12) and III (GBU-24, GBU-27, LGTR-60). (LGTR-60 is actually a Paveway II but with a better flight profile and should be used to train delivery of Paveway III)



Figure 137 GBU-10 Paveway II



Figure 138 GBU-24 Paveway III



Figure 140 GBU-12 Paveway II



Figure 139 GBU-27 Paveway III

The main difference between the two generations of weapons is the type of control.

The newer Paveway III has implemented a proportional control in place of the older "bang-bang" control of the Paveway II (either full deflection of the control fins, or none).

This gives the Paveway III a more efficient flight path, and with the enhancement of the seeker field of view and larger fins, the range of the weapon was increased.

In BMS the only difference between the two is the range, for now.

But as a good practice you should start to use the lasing time the correct way:

- Paveway II: lasing should start 12 sec before impact (to minimize the movements of the “bang-bang” control, and consequently the bomb falling short or long)
- Paveway III: 20 sec or more, in BMS it is advised to start lasing manually as soon as the bomb is released

3.5.1 LGB SMS page

The LGB SMS page is the same as any general purpose bomb



3.5.2 LGB CNTL page

The LGB Control page (accessed by OSB #5 of the SMS page) is the same as any general purpose bomb.

For LGB, C1 should be used and set accordingly as there is not need for Burst parameters.

The LADD settings in regard to OSB #6 are not implemented in BMS.

The RELEase ANGLE is the desired pull up angle for LOFT attack but this is still buggy in BMS



3.5.3 LASER UFC PAGE

See BMS dash-1 for a complete explanation of the LASER UFC page



```

LASER 6
TGP CODE 1688
LST CODE *1688*
A-G: TRNG A-A: TRNG
LASER ST TIME 16 SEC

```

In order for a LGB to guide on a laser beam, their code must match.

An LGB is set on the ground with a specific laser code, usually by the weapon crew and cross check by the pilot during its pre-flight.

This is done in BMS at the UI arming screen before flight.

As a pilot you will pre-flight your loaded weapons and you will cross check the bomb code. If you need to change it, you may input another code and confirm the change by pushing the button SET CODE.

Please note, the bomb code cannot be changed after take-off.



The laser illuminating the target must be set to the same LGB code.

This is set in the TGP code of the LASER UFC page.

- If you lase your own bombs with your TGP pod, set your UFC page to reflect your bomb code.
- If you need to lase your wingman bombs (buddy lasing) you must set the code of your wingman bombs on your UFC page.

For specific operations and procedure releasing laser Guided bombs, refer to the TGP chapter in this manual, UFC, HUD and MFD chapter in dash-1 and training manual for Paveway II release procedure training (Training mission #11).

3.6 MAN-IN-THE-LOOP WEAPONS

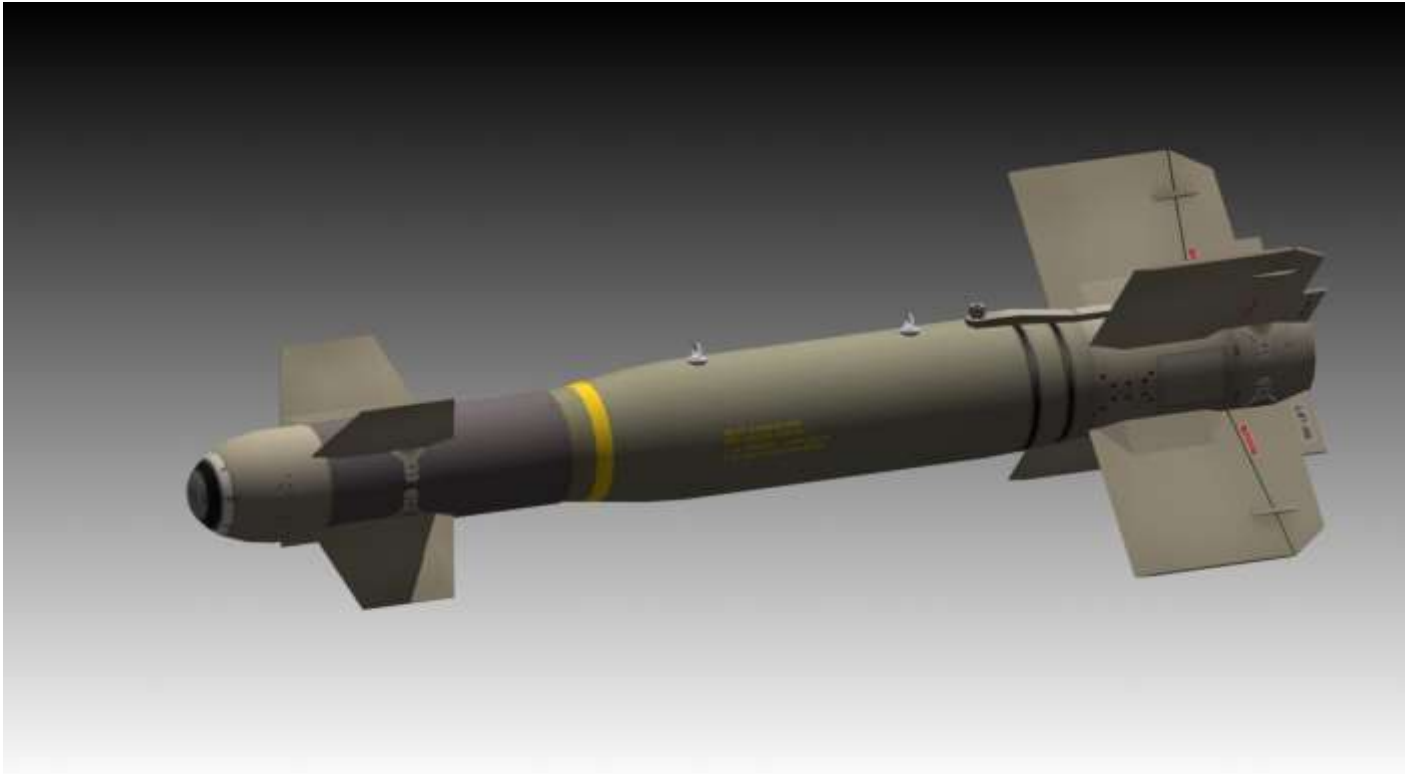

Figure 141 GBU-15

Man-in-the-Loop weapons are a family of weapons that allows the pilot/WSO to control the weapon after launch via data link. The pilot/WSO can guide the weapon manually to the target by sending the weapon maneuvering commands via data link, while watching the video image that is received from the weapon in real-time.

3.6.1 General Information

Data Link Pod: In order to keep communication with an airborne Man in the Loop weapon, the launching aircraft must carry a data link pod that matches the weapon. Data Link pods will be automatically loaded for AI controlled jets if the loadout decided by the ATO contains a MITL weapon. Human players must load the pod manually if they decide to load a MITL weapon.

Note: At this moment, mutual guidance of weapons is not implemented, so every launching aircraft must carry its own Data Link Pod.



Figure 142 AGM-84H SLAM-ER

The following table contains data for every Man in the Loop weapon that exists in the database and the Data Link Pod it requires, the middle "type" column specifies the value that is expected to be in the weapon's FM file in order to match a given pod:

Data Link Pod	Data Link Pod Type	Supported Weapons	Weapon Platforms
AN/AXQ-14	1	GBU-15 AGM-130	F-16D Block 30 IAF, D40, D40 IAF, F-16I, F-15I, F-4, F-15E
AN/ASW-55	2	AGM-142 Delilah	F-15I, F-15C-IAF, F-4 ESK, F-4F
AN/AWW-9 (aka AN/AWW-13)	3	AGM-62-1 AGM-62-2 AGM-84E SLAM AGM-84H SLAM-ER	F/A-18 F/A-18, F-4E IAF F/A-18, AV-8B+, F-15K
APK-9	4	AS-18	MiG-27, Su-30

Table 11 Data Link Pods and supported MITL weapons

Weapon Generation

There are many variants of Man-in-the-Loop weapons—five different generations exist in BMS:

- 0th Generation – old and primitive Man-in-the-Loop weapons. They have no support for flight stages at all. Manoeuvring commands sent to the weapon will be executed directly—meaning that the weapon is actually "flown" by the operator. Careless manoeuvring commands may easily lead to loss of control over the weapon due to instability. An example for such weapon is the AS-18 missile.
- 1st Generation—supports three different flight stages. Commands sent to the weapon move the aiming cross (and the video image) and the weapon executes yaw/pitch corrections accordingly in a direct fashion. There is no stabilized terminal stage. An example for such weapon is the GBU-15 bomb.
- 2nd Generation—supports three different flight stages. Commands sent to the weapon move the aiming cross (and the video image) and the weapon executes yaw/pitch corrections. Corrections in TRANS mode are done only as soon as the operator stops moving the aiming cross. TERM mode supports a stabilized stage. There is an INS in the weapon so SPI reference position is supported. An example for such a weapon is the AGM-130 missile.
- 3rd Generation – weapons with on board GPS and autopilot capability. 2 flight stages exist, CRUS and TERM. Relevant flight data relative to the target position will appear on the MFD:

Azimuth,

Speed,

Altitude,

Range,

Time-to-go,

Range to the reference SPI,

Bearing relative to the reference SPI.

Commands sent to the weapon move the aiming cross (and the video image) and the weapon executes yaw/pitch corrections. While in CRUS mode the weapon will keep a pre-defined altitude and execute yaw corrections only when a specific command to do correction comes from the operator. Autopilot function will keep the weapon aimed towards the reference SPI when in CRUS mode (in TERM mode the autopilot can be engaged but it has no functionality). TERM mode supports a stabilized stage. An example for such a weapon is the AGM-84E SLAM.

- 4th Generation – same characteristics as 3rd Generation but with an additional ability for a Go-Around function which supports automatic loiter over the target area. An example weapon is the AGM-84H SLAM-ER.

3.6.2 SMS Page

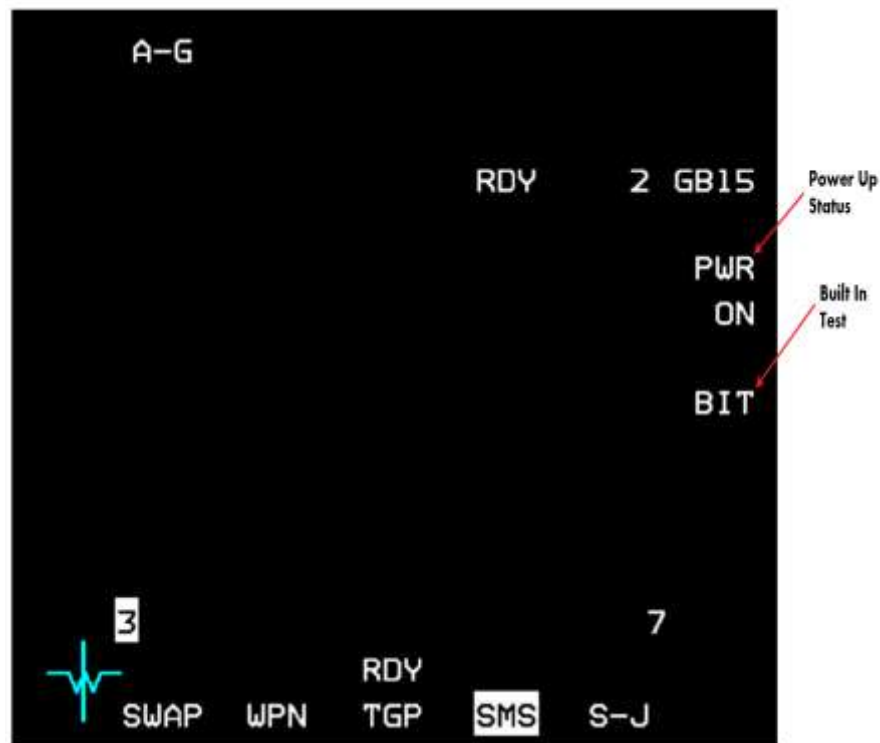

Figure 143 Man-in-the-Loop SMS page

Man-in-the-Loop weapons SMS page contains:

- Power up status – ON/OFF states
- BIT

Power: Once power is applied via OSB 7, all Man-in-the-Loop weapons on all stations will be powered up. A short BIT lasting a few seconds will be executed.

BIT: Built-In test on demand can be applied by pressing OSB 8. The BIT mnemonic will highlight for a few seconds during the BIT. During BIT the weapon cannot be launched.

Warm-up Time: There is a warmup time of three minutes before the weapon's video will be available on the WPN page. While warm-up is ongoing a "NOT TIMED OUT" message will appear on the SMS and WPN pages. As soon as the three minutes of warm-up time period had passed, the WPN page will display the video image that comes from the weapon's sensor (IR or TV).

3.6.3 WPN Page

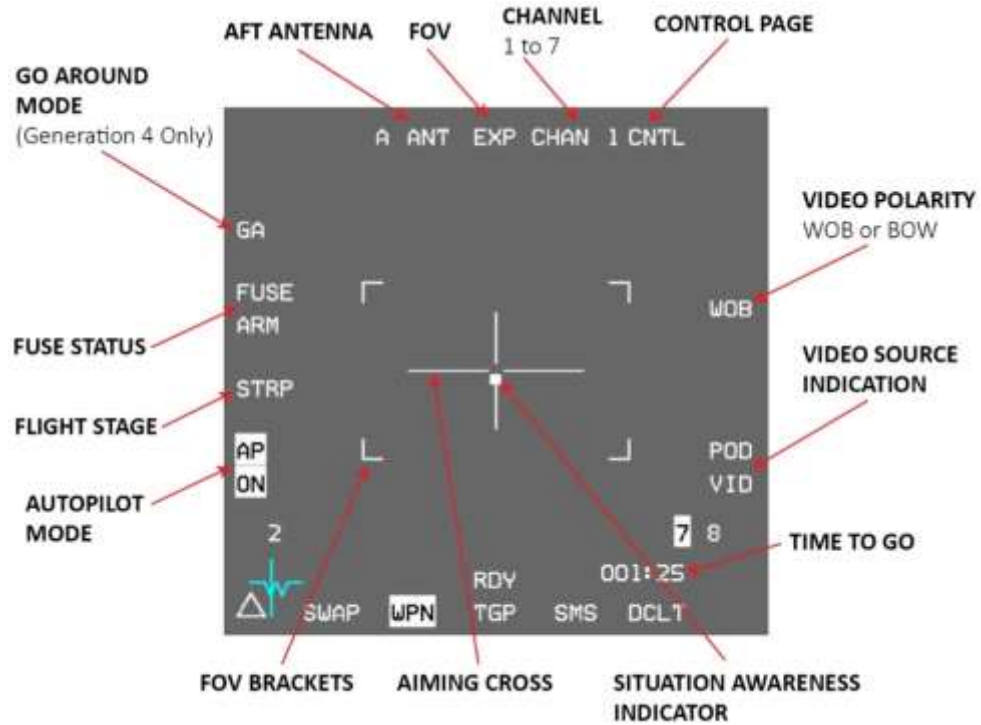

Figure 144 Man-in-the-Loop WPN page - Strapped

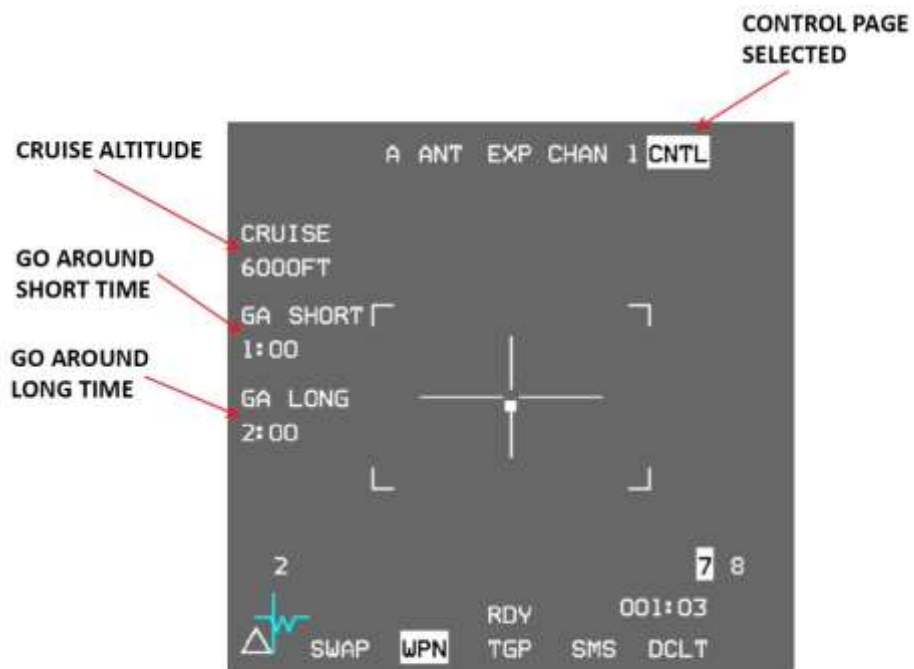

Figure 145 Man-in-the-Loop WPN Control page - Strapped

Video Source: The POD VID label can be highlighted or un-highlighted, which indicates whether the displayed video image is coming through the data link pod or not. When the image is coming through the data link pod it means the weapon is airborne (launched) and it is transmitting the video image through the pod. If the label is not highlighted the video image is coming from a weapon still strapped to the aircraft.

By pressing OSB 8 when there is a launched weapon airborne the pilot/WSO may switch between managing an airborne weapon or a strapped weapon that is on the aircraft.

Pressing OSB 8 POD VID when there is no airborne weapon to communicate with will result in a "NO SIGNAL" message appearing on the MFD and no video image will be visible.

If no matching Data Link Pod is loaded the POD VID label will be blanked.

Video Polarity: Can be selected between BOW/WOB. The MFD symbology will turn black/white accordingly. There is no image polarity change, but only the symbology will change. The image will always be white hot for IR sensors.

FOV: The EXP label will always appear under OSB 3. Pressing the OSB will switch FOV between wide and narrow.

Channel: Channels 1-7 are available to control up to seven airborne weapons. Pressing OSB 4 will switch to the next channel. When a weapon is launched the selected channel at the moment of launch will be the channel used to control that weapon after launch. The channel cannot be switched after the missile is launched.

AFT Antenna: The A ANT label highlighted or un-highlighted will indicate if the rear antenna of the data link pod is used to keep data link communication with the weapon. Depending on the position of the weapon and the aspect of the aircraft, the rear antenna may need to be used in order to stay in contact with the weapon.

Signal strength and communication with the weapon depends on the ability of the pod's antenna to receive the signals from the weapon. The angular limitations of the front and AFT antennas are given in the table below:

ANT Mode	Azimuth limits (in degrees)	Elevation limits (in degrees)
Front	+/- 60°	+2° (looking up) -60° (looking down)
AFT	+/- 60° to +/- 165°	+5° (looking up) -90° (looking down)

The pilot must fly the aircraft inside the angular limitations in order to keep data link communication with the weapon. When there is no communication a "NO SIGNAL" message will appear on the WPN MFD instead of the video picture and the weapon will not receive any commands signals.

Weapon Stage:

Weapon stage appears at OSB 17 and can be changed hands-off by pressing OSB 17 or hands-on via TMS-Up when the WPN page is SOI. For Generation 1 and 2 weapons, once the next stage is selected it is impossible to get back to a previous stage. Generation 3 and 4 weapons can get back from TERM stage to CRUS stage and also get out of ground stabilized TERM mode back to none-stabilized mode. Generation 0 weapons do not use stages at all and OSB 17 will be blanked when such a weapon is airborne.

There are 4 possible stages:

1. STRP – Strapped – The weapon is still on the aircraft, pre-launch.
2. LOFT – For weapons of generations 1 and 2 only. The weapon at LOFT stage is airborne and will keep a straight and level flight in order to save energy and not lose altitude.
3. TRANS/CRUS:

TRANS - Transmission – For weapons of generations 1 and 2 only. The weapon in TRANS stage will keep the nose at -3 degrees relative to the horizon. The weapon will correct azimuth according to the operator's aiming cross movements. Weapons of generation 1 will yaw immediately and continuously while weapons of generation 2 will only start yawing when the operator stopped slewing in order to save energy on potentially unnecessary maneuvers.

CRUS – Cruise – For weapons of generations 3 and 4 only. After launch the weapon will enter CRUS mode and will level off at either launch altitude if cruise altitude was not defined, or at the defined cruise altitude. If autopilot is engaged the weapon will correct its bearing towards the SPI reference, without autopilot the weapon will fly straight ahead and will perform yaw corrections according to the aiming cross position only when the operator sends a command via TMS-Right.

At TRANS/CRUS stages the weapon will not use its full manoeuvrability, but will only correct yaw gently in order to save energy.

4. TERM – Terminal – The weapon will become fully manoeuvrable and will align its attitude towards the target according to the command coming from the operator. At this stage the situation awareness indicator should be closing on the centre of the aiming cross, meaning that the weapon's head is aligning towards the target. For generation 2 weapons and above, terminal stage also has a ground stabilized mode that will be entered once the pilot commands TMS-Up when already in TERM stage. Weapons of generation 3 and 4 can get out of ground stabilized mode via TMS-Down.
- 5.

Fuse State: FUSE ARM mnemonic at OSB 18 will be highlighted if the weapon's fuse is active. The fuse can be armed before the weapon is launched, or while the weapon is airborne. The fuse must be armed for the weapon to detonate when hitting the ground/target.

AP Mode: The Autopilot Mode mnemonic at OSB 16 will appear on the MFD For weapons of generation 3 and 4. The options are ON/OFF and the mnemonic will be highlighted when ON mode is selected. AP ON means that the weapon will align its bearing with the reference SPI position. Autopilot Status may be changed while the weapon is airborne.

3.6.3.1 WPN Page for Airborne Weapon

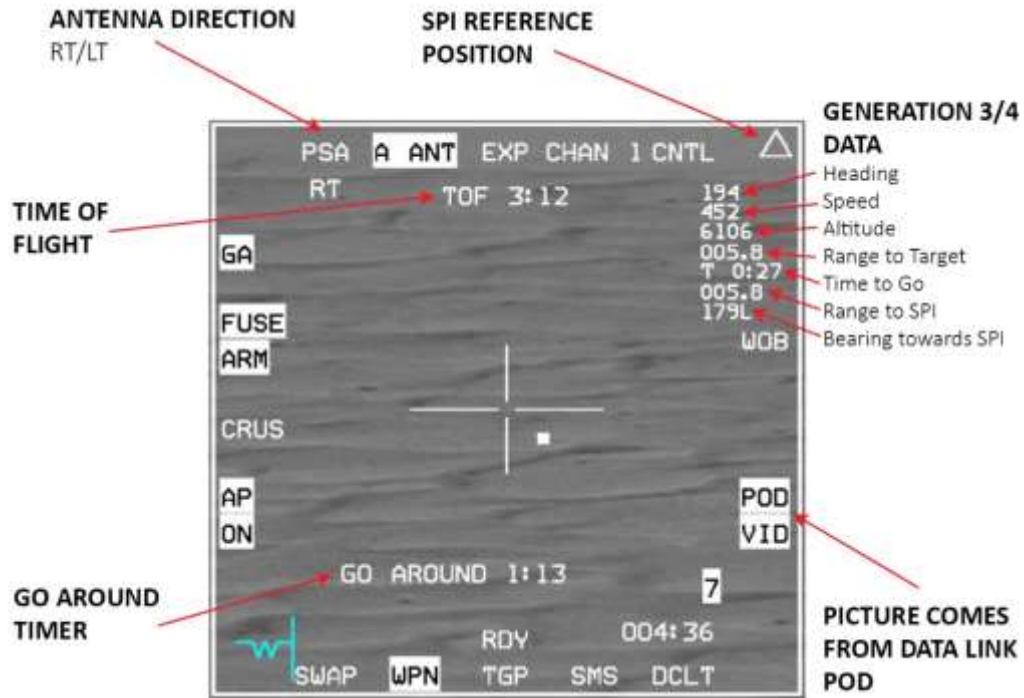

Figure 146 Man-in-the-Loop WPN page - Airborne

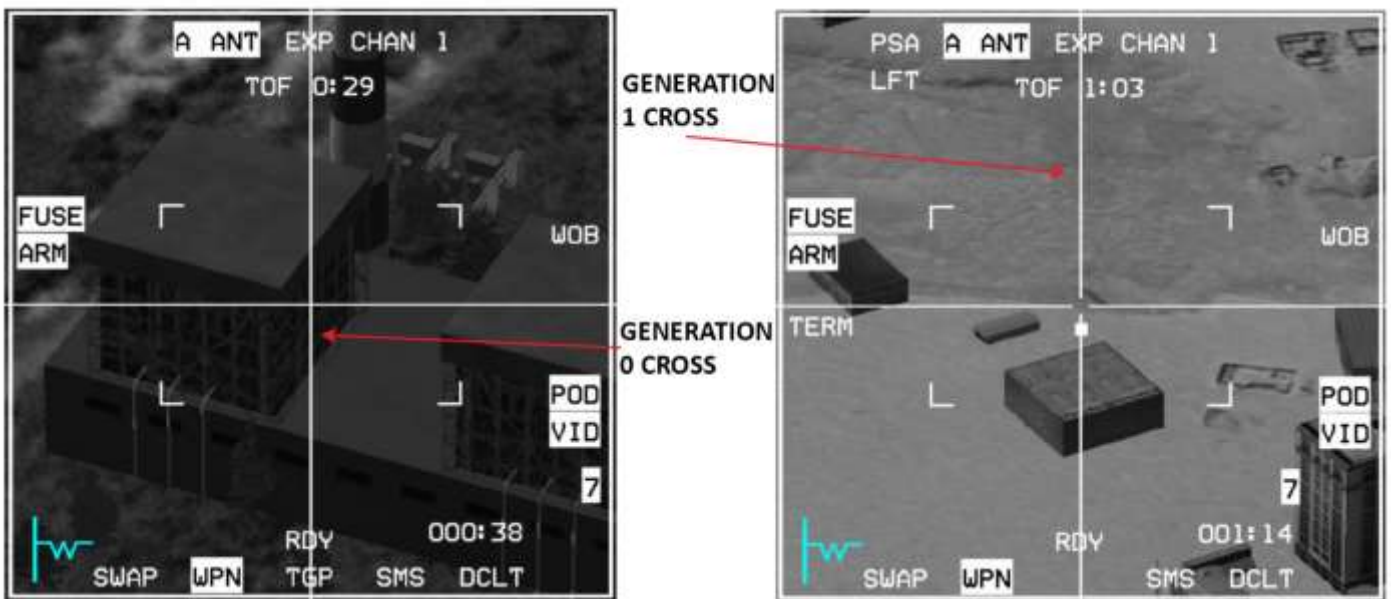

Figure 147 Generation 0/1 Airborne WPN page

TOF: The TOF indication represents a timer that counts minutes and seconds since the weapon was launched.

PSA Side: The PSA Side indication indicates the direction of the weapon's antenna relative to the position of the target.

SPI Reference Position: For Generation 2 - 4 weapons a Reference SPI position, represented by a triangle, is shown in the display. While the weapon is strapped to the Aircraft the triangle will move if the SPI position in the system is moved. After launch the SPI position will represent the SPI position of the system at the time of launch. After launch The SPI reference position may be updated by the operator via 2 x TMS-Right < 0.5 seconds and if Autopilot is engaged the weapon will correct heading towards the updated SPI reference position.

Generation 3/4 Data: For Generation 3 and 4 weapons a data set will be displayed in the top-right corner of the video image. The data set will include the following information:

- Heading – The current heading of the weapon.
- Speed – Speed of the weapon in knots.
- Altitude – The altitude of the weapon in feet above sea level.
- Range To Target – The range to the current target (where the aiming cross is pointing) in Nm.
- Time To Go – Time until the weapon will impact on the current target. Format is M:SS for minutes and seconds.
- Range To SPI – Range to the reference SPI in Nm.
- Bearing towards SPI – The bearing relative to the reference SPI. R/L will indicate Right or Left.

Cruise Altitude: Generation 3 and 4 weapons have an option to set a cruise altitude that the weapon will try to keep while in CRUS flight stage. The cruise altitude setting is positioned in the WPN Control page near OSB 19. Pressing the OSB will switch the MFD to a cruise altitude data input page. The input must be made of exactly 3 digits which will define the flight level of the cruise altitude. For example in order to set 5000 feet, the input in the data page should be 050.

Go Around Mode: Generation 4 weapons have an option to loiter in the target area without operator involvement. GA mode can be set to SHORT, LONG or OFF. Setting it to SHORT or LONG when the Autopilot is engaged will command the weapon to fly past the SPI reference position without changing heading. The weapon will keep flying away until 1 minute remains on the GA timer when the weapon will start turning back towards the SPI position. The turnaround manoeuvre should take about 1 minute, so the weapon should be aligned towards the target when the timer reaches 0.

If GA mode is set to SHORT or LONG then the GA label at the centre bottom part of the MFD will display the GA SHORT/LONG mode if the weapon has not yet passed the SPI position, or the time until the weapon is expected to be aligned with the SPI if the SPI has already been passed. Once The GA timer has started counting it will keep showing updated numbers even if communication with the weapon is lost momentarily; this is useful as the operator can use the time until the weapon comes back from the GA manoeuvre to operate the aircraft.

While in TERM mode, Go Around can be commanded with TMS-Right, the weapon will go back to CRUS flight stage, AP will be engaged and GA mode will be set to SHORT. A second TMS-Right will switch the GA mode to LONG and another TMS-Right will switch GA OFF. The GA SHORT and LONG timers may be set in the Control page via OSBs 18 and 17 accordingly. Pressing one of the other OSBs will switch the WPN page to Go Around Time data input mode; the input must be made of exactly 3 digits which will define minutes and seconds in M:SS format. For example, for entering 1:30 to the timer, the input in the data input page should be 130.

3.6.3.2 **Stabilized WPN Page for Airborne Weapon**

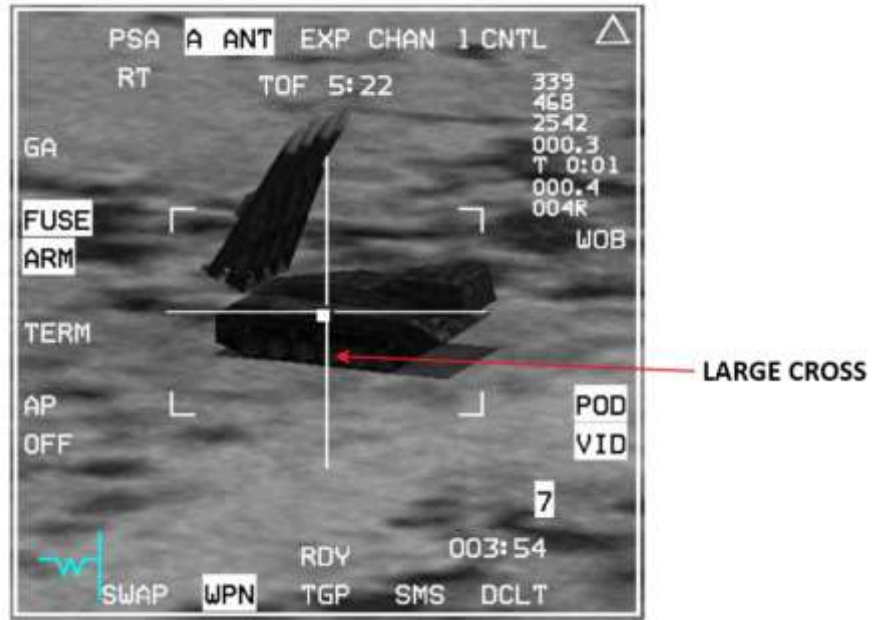

Figure 148 Man-in-the-Loop WPN page – Generation 3/4 – Ground Stabilized

In order to improve aiming in the final moments before reaching the target, generation 2, 3 and 4 weapons can enter ground stabilized mode during the terminal flight stage. Commanding TMS-Up while in TERM will cause the weapon's sensor to attempt to enter ground-stabilized mode. If it succeeds, the video image will become ground stabilized.

- Generation 3/4 weapons in Ground Stabilized mode have a much larger cross than in none-stabilized modes. The cross will move with slew commands, similar to AREA mode in the TGP. The image will be stable and the situational awareness indicator will show the weapon's attitude with relation to the target position.

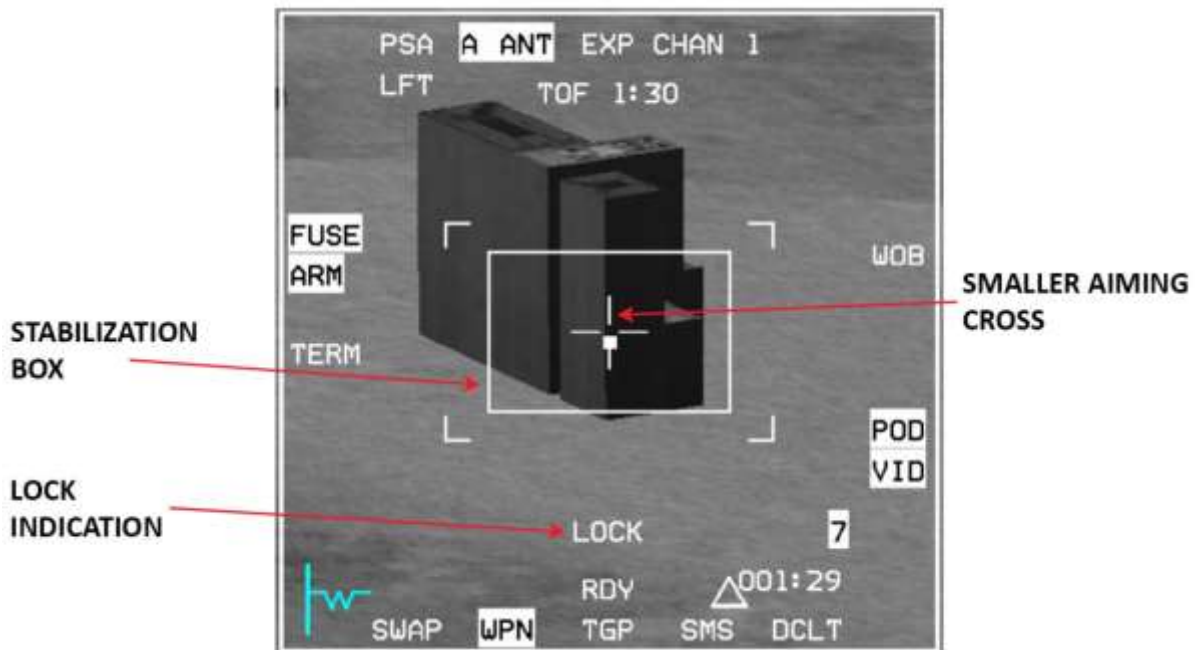

Figure 149 Man-in-the-Loop WPN page – Generation 2 – Ground Stabilized

- Generation 2 Ground Stabilized mode has the following additional information:
 - Stabilization Box.
 - LOCK mnemonic – To notify that the aimpoint is locked by the weapon.
 - The Aimpoint Cross will become smaller.

When in ground stabilized mode, in order to change the aimpoint of the weapon, the operator should move the cursor as usual. As the cursor is moved a second cross will appear on the video image and will move away from the current aimpoint towards the new aimpoint. If the operator commands TMS-Up the "LOCK" mnemonic will disappear from the display and the original aiming cross will move towards the new aimpoint and settle there to join the new cross. At this point the "LOCK" mnemonic will reappear to notify that the sensor is now locked on the new aimpoint.

3.6.4 Man in the Loop Hands-On Controls

Table 12 Man in the Loop Hands-On Controls

Control	Functionality	Condition
TMS-Up	Toggle Flight Stage/ Enter stabilized Mode	Generations 1-4
TMS-Up Long	Toggle Fuse Arm	
TMS-Right	Command/ Toggle Go Around mode	Generation 4
2xTMS-Right < 0.5 Seconds	Update SPI Reference position to the cross aimpoint position	Generations 2-4
TMS-Right Long	Command weapon to align azimuth with the cross aimpoint	Generations 3-4 in CRUS flight stage
TMS-Left	Toggle Polarity	
2xTMS-Left < 0.5 Seconds	Toggle AFT-Antenna	
TMS-Left Long	Toggle Autopilot	Generations 3-4
TMS-Down	Cancel Ground Stabilized mode	Generations 2-4 in TERM mode
	Switch from TERM mode back to CRUS	Generations 3-4 in TERM mode

3.6.5 HUD



Figure 150 Man-in-the-Loop Weapon HUD

When a Man-in-the-Loop weapon is selected the HUD will be in Slave mode, the TD-Box will be located where the SPI is pointing and a 10 mr LOS reticle will represent the weapon's LOS position. The LOS reticle represents the LOS of the current strapped (next to be launched) weapon only.

3.6.6 HSD

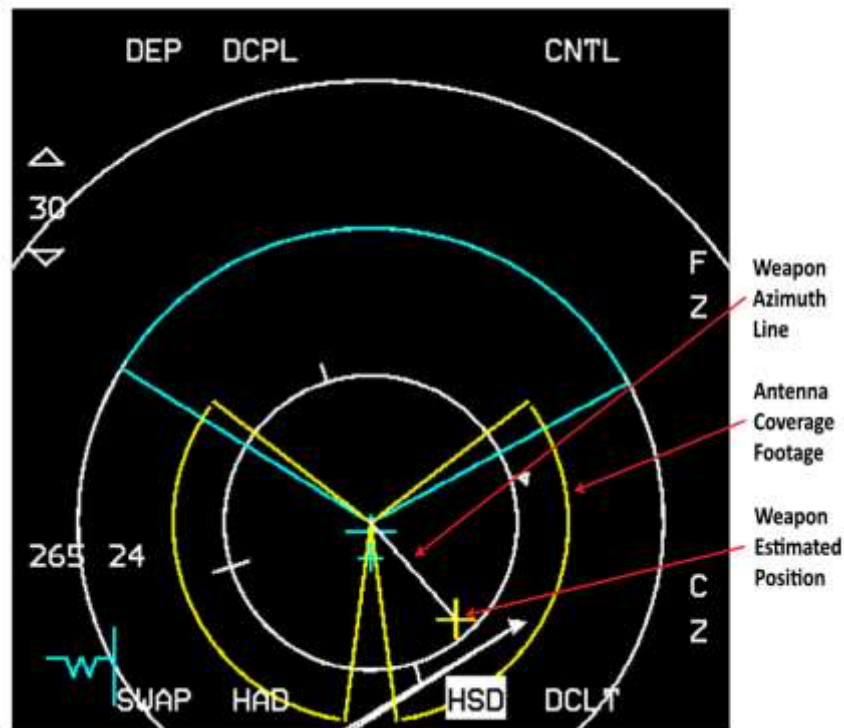

Figure 151 Man-in-the-Loop Weapon HSD

When a Man-in-the-Loop weapon is selected, the HSD will display additional symbology.

Antenna Coverage Footage: This represents the footage of the antenna mode that is currently selected, relative to the AC position. It will be displayed irrespective of the currently selected HSD range. The antenna footage will be displayed with or without an airborne weapon.

Weapon Estimated Position: When there is a weapon airborne the estimated position of that weapon is displayed on the HSD as a yellow cross. If communication with the weapon is lost the cross position will be based on the last known position and estimated movement since.

Weapon Azimuth Line: When there is a weapon airborne an azimuth line is displayed on the HSD. The line will originate from the AC symbol and end at the weapon's estimated position. When communication with the weapon is lost this azimuth line will be dashed.

Note: The weapon dependent symbology is always related to the airborne weapon that is currently being managed according to the selected channel.

3.6.7 Weapon Release Procedure

1. Power up the weapon from the SMS page, early enough for the 3 minutes warm-up duration.
2. Set the SPI position to the general area of the target (optional).
3. Select the WPN page and make it SOI.
4. Use the cursor and aircraft maneuvers to have the weapon's LOS close to the target position (optional).
5. Set TGP/HSD on the other MFD to aid post-launch operation (optional).
6. When in-range – Pickle to release the weapon.
7. Manoeuvre the aircraft in order to fly away from the target as necessary (optional).
8. Select the appropriate antenna mode and verify that data link communication with the weapon is stable.
9. Watch the weapon course and verify that it is on track to target, if not then move to an appropriate flight stage and correct course as necessary.
10. When close to target, enter terminal stage and arm the fuse.
11. For finer aiming, stabilized mode should be entered (optional).
12. Correct course or target position (stabilized mode) in order to hit the target effectively.

Note: These release procedures may not *all* be relevant for *all* generations of weapons. Generation 0 weapons in particular need to be managed closely right after launch because of the lack of flight stages support.

Note: Man-in-the-Loop weapons are always hot and will be launched whenever the pickle is depressed, even if launch conditions aren't satisfied.

3.7 AGM-84 HARPOON

The AGM-84 Harpoon is an all-weather, over-the-horizon, anti-shiping missile system produced by McDonnell Douglas (now Boeing). Its low-level, sea-skimming cruise capability, active radar guidance and warhead design assure high survivability and effectiveness. It is carried by the Block 40, 40 EAF, 52+ EAF, KF-16, F/A-18, F-15K and AV-8B+.



Figure 152 AGM-84A Harpoon

3.7.1 SMS Base Page

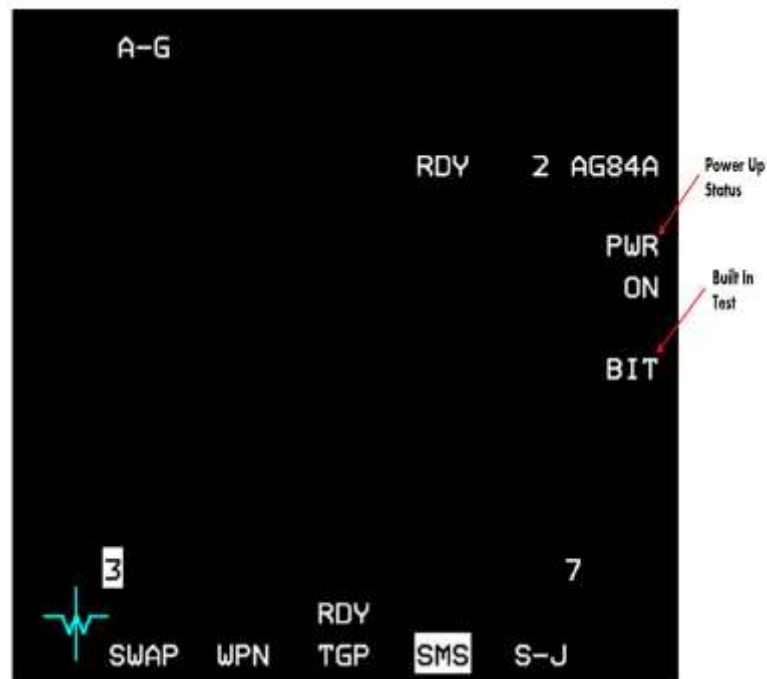

Figure 153 Harpoon SMS Page

When a Harpoon missile is selected, "AG84" is displayed adjacent to OSB 6 and the total number of Harpoon missiles loaded in inventory is displayed left of the mnemonic.

Missile Power: Missile power is selected via OSB 7. Each Harpoon missile must be powered on separately. Once powered up, the missile will stay powered on until it's powered off, A-G mode is exited or another weapon type is selected. The missile doesn't have to be powered on for setup operations but must be powered on before launch.

Built In Test: Harpoon BIT mnemonic will show up adjacent to OSB 8 when the missile has power. Pressing OSB 8 will perform a BIT on the selected station. Bit takes a couple of seconds and the BIT mnemonic will be highlighted when BIT is ongoing. After BIT finished, the missile status will show up at the station numbers display area, if BIT passed successfully then the station number will show up, otherwise there will be an "F" for a failed station, "D" for degraded or "H" for Hung station.

3.7.2 WPN Page

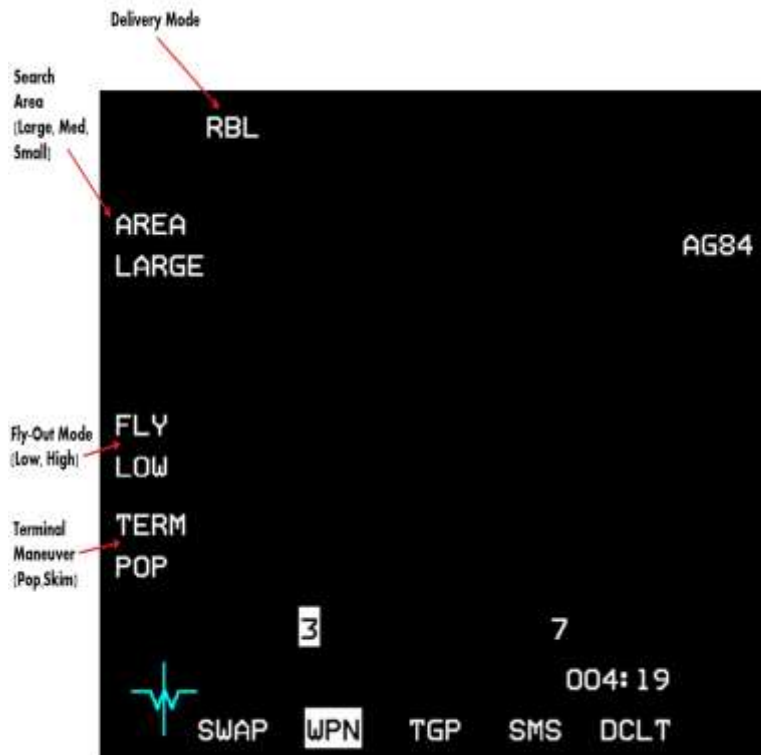

Figure 154 Harpoon WPN Page

3.7.3 Harpoon HUD

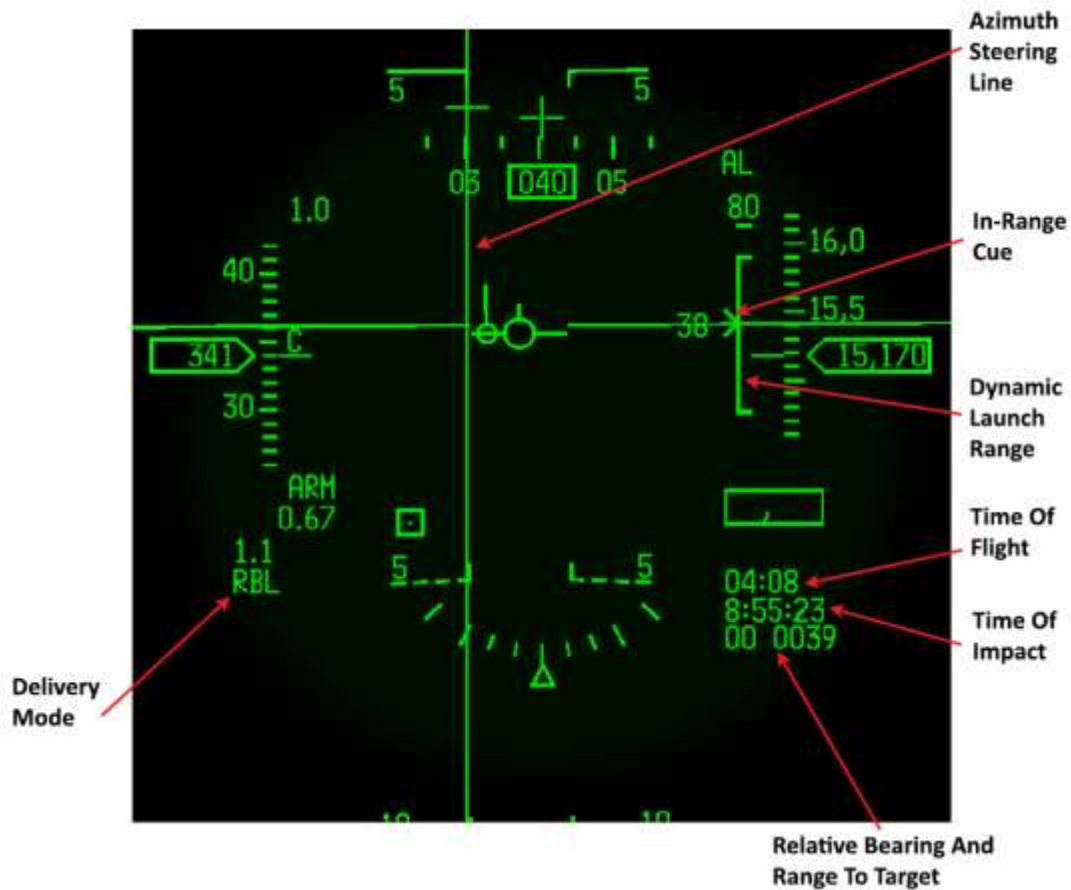

Figure 155 Harpoon HUD Symbology

HUD Harpoon Symbology: In RBL mode on the right side of the HUD is a Harpoon dynamic launch zone (DLZ) scale (the DLZ is not displayed in the BOL or LOS modes). Displayed just left of the in-range cue is the current range to target in nautical miles. The bearing and range to the target, is displayed in the bottom right corner of the HUD. Above the bearing and range is the estimated time of impact. Above the time of impact is the missile time of flight. In BOL and LOS modes the ASL isn't displayed, there is no TD-Box and no DLZ scale.

3.7.4 RBL – Range and Bearing Launch Mode

RBL mode is used when target position is well known. The Harpoon in RBL mode will launch against the SPI position and will search for a target in the SPI area according to the pre-defined search pattern.

Harpoon Search Area Size: The search area size appears in RBL mode only adjacent to OSB 20 and commands the Harpoon search distance from the SPI. Small and Medium options are recommended to be used when there is a group of ships at the target area that some must be avoided. The Large search size is the default.

Harpoon Fly-Out Mode: Fly out mode appears adjacent to OSB 18 in RBL and BOL modes and after launch the Harpoon will fly in a low or high profile according to the selected value (HIGH or LOW). Even if High fly out mode is selected, the Harpoon will switch to low profile after some distance from the launch point.

Harpoon Terminal Manoeuvre: The Harpoon terminal manoeuvre option is displayed adjacent to OSB 17 in RBL and BOL modes and the Harpoon will fly the selected profile for the terminal phase. The Pop option causes the missile to be a more difficult target for ship's air defences.

Harpoon Delivery Mode: The selected delivery mode displays adjacent to OSB 1, the options are RBL, BOL and LOS.

RBL Weapon Delivery Procedure:

1. Select the station that the Harpoon should be launched from.
2. Select the desired STPT and slew the SPI as necessary to be the closest to the target position.
3. Select missile parameters as required (Search area, flight profile, terminal manoeuvre).
4. Power up the missile and wait for it to be ready.
5. Verify on the HUD that the missile is in-range.
6. Hold the pickle until the missile is released.

3.7.5 BOL – Bearing Only Launch Mode

BOL mode is a mode that can be used when the target bearing is known but target range is unknown. In BOL mode there is no search area selection. After release the missile will keep heading towards the aircraft heading at launch moment (Boresight). After some time the missile will turn on its radar and will start searching for the target closest to its flight path.

BOL Weapon Delivery Procedure:

1. Select the station that the Harpoon should be launched from.
2. Point the aircraft heading towards the bearing of the target.
3. Select missile parameters as required (flight profile, terminal manoeuvre).
4. Power up the missile and wait for it to be ready.
5. Hold the pickle until the missile is released.

3.7.6 LOS – Line Of Sight Launch Mode

LOS mode is a degraded mode that usually used when there is some malfunction that causes RBL and BOL modes to be unavailable. In LOS mode the missile will keep heading towards the aircraft heading at launch moment (boresight) and will start searching for a target immediately afterwards. In LOS mode the missile will lock on the first target that is acquired by its radar.

Weapon Base Page: In LOS mode all the options are removed from the WPN page and the missile will use default and pre-plan patterns to find the target after launch.

LOS Weapon Delivery Procedure:

1. Select the station that the Harpoon should be launched from.
2. Select LOS mode.
3. Point the aircraft heading towards the estimated bearing of the target.
4. Power up the missile and wait for it to be ready.
5. Hold the pickle until the missile is released.

PAGE INTENTIONALLY BLANK